

---

---

**Thermoplastics piping systems for  
non-pressure underground drainage  
and sewerage — Thermoplastics  
shafts or risers for inspection  
chambers and manholes —  
Determination of resistance against  
surface and traffic loading**

*Systèmes de canalisations thermoplastiques pour branchements  
et collecteurs d'assainissement enterrés sans pression — Éléments  
de réhausse thermoplastiques pour boîtes d'inspection et de  
branchement ou regards — Détermination de la résistance aux  
charges de remblai et de circulation*

<https://standards.iteh.ai/catalog/standards-iteh/9796-cc4fdb96bf6/iso-13266-2022>



iTeh STANDARD PREVIEW  
(standards.iteh.ai)

ISO 13266:2022

<https://standards.iteh.ai/catalog/standards/sist/1d05170d-110d-474f-9796-cc4fdb96bf6/iso-13266-2022>



**COPYRIGHT PROTECTED DOCUMENT**

© ISO 2022

All rights reserved. Unless otherwise specified, or required in the context of its implementation, no part of this publication may be reproduced or utilized otherwise in any form or by any means, electronic or mechanical, including photocopying, or posting on the internet or an intranet, without prior written permission. Permission can be requested from either ISO at the address below or ISO's member body in the country of the requester.

ISO copyright office  
CP 401 • Ch. de Blandonnet 8  
CH-1214 Vernier, Geneva  
Phone: +41 22 749 01 11  
Email: [copyright@iso.org](mailto:copyright@iso.org)  
Website: [www.iso.org](http://www.iso.org)

Published in Switzerland

# Contents

	Page
Foreword.....	iv
<b>1 Scope.....</b>	<b>1</b>
<b>2 Normative references.....</b>	<b>1</b>
<b>3 Terms and definitions.....</b>	<b>1</b>
<b>4 Principle.....</b>	<b>1</b>
<b>5 Apparatus.....</b>	<b>2</b>
<b>6 Number of test pieces.....</b>	<b>4</b>
<b>7 Conditioning and test temperatures.....</b>	<b>4</b>
<b>8 Procedure.....</b>	<b>4</b>
<b>9 Test parameters.....</b>	<b>5</b>
<b>10 Test report.....</b>	<b>5</b>

**iTeh STANDARD PREVIEW**  
(standards.iteh.ai)

[ISO 13266:2022](https://standards.iteh.ai/catalog/standards/sist/1d05170d-110d-474f-9796-cc4fdbe96bf6/iso-13266-2022)

<https://standards.iteh.ai/catalog/standards/sist/1d05170d-110d-474f-9796-cc4fdbe96bf6/iso-13266-2022>

## Foreword

ISO (the International Organization for Standardization) is a worldwide federation of national standards bodies (ISO member bodies). The work of preparing International Standards is normally carried out through ISO technical committees. Each member body interested in a subject for which a technical committee has been established has the right to be represented on that committee. International organizations, governmental and non-governmental, in liaison with ISO, also take part in the work. ISO collaborates closely with the International Electrotechnical Commission (IEC) on all matters of electrotechnical standardization.

The procedures used to develop this document and those intended for its further maintenance are described in the ISO/IEC Directives, Part 1. In particular, the different approval criteria needed for the different types of ISO documents should be noted. This document was drafted in accordance with the editorial rules of the ISO/IEC Directives, Part 2 (see [www.iso.org/directives](http://www.iso.org/directives)).

Attention is drawn to the possibility that some of the elements of this document may be the subject of patent rights. ISO shall not be held responsible for identifying any or all such patent rights. Details of any patent rights identified during the development of the document will be in the Introduction and/or on the ISO list of patent declarations received (see [www.iso.org/patents](http://www.iso.org/patents)).

Any trade name used in this document is information given for the convenience of users and does not constitute an endorsement.

For an explanation of the voluntary nature of standards, the meaning of ISO specific terms and expressions related to conformity assessment, as well as information about ISO's adherence to the World Trade Organization (WTO) principles in the Technical Barriers to Trade (TBT), see [www.iso.org/iso/foreword.html](http://www.iso.org/iso/foreword.html).

This document was prepared by Technical Committee ISO/TC 138, *Plastics pipes, fittings and valves for the transport of fluids*, Subcommittee SC 1, *Plastics pipes and fittings for soil, waste and drainage (including land drainage)*.

This second edition cancels and replaces the first edition (ISO 13266:2010), which has been technically revised.

The main changes are as follows:

- normative references have been updated;
- definitions have been removed;
- an additional classification (“Class C”) has been implemented in [Table 1](#);
- technical changes have been made in [8.2](#) and [Clause 10](#);
- this document has been editorially revised.

Any feedback or questions on this document should be directed to the user's national standards body. A complete listing of these bodies can be found at [www.iso.org/members.html](http://www.iso.org/members.html).

# Thermoplastics piping systems for non-pressure underground drainage and sewerage — Thermoplastics shafts or risers for inspection chambers and manholes — Determination of resistance against surface and traffic loading

## 1 Scope

This document specifies a method of testing the resistance of the upper assembly of inspection chambers and manhole components against surface and traffic loading.

It is not applicable to requirements for testing the cover and frame. Those requirements are specified in EN 124-1 or other standards, depending on the material.

NOTE Upper assembly components normally include shafts or risers, cones, telescopic adapters and near surface components.

## 2 Normative references

The following documents are referred to in the text in such a way that some or all of their content constitutes requirements of this document. For dated references, only the edition cited applies. For undated references, the latest edition of the referenced document (including any amendments) applies.

ISO 13260, *Thermoplastics piping systems for non-pressure underground drainage and sewerage — Test method for resistance to combined temperature cycling and external loading*

EN 124-1, *Gully tops and manhole tops for vehicular and pedestrian areas — Part 1: Definitions, classification, general principles of design, performance requirements and test methods*

CEN/TS 1046, *Thermoplastics piping and ducting systems — Outside the building structures for gravity and pressurised systems — Trench installation*

## 3 Terms and definitions

No terms and definitions are listed in this document.

ISO and IEC maintain terminology databases for use in standardization at the following addresses:

- ISO Online browsing platform: available at <https://www.iso.org/obp>
- IEC Electropedia: available at <https://www.electropedia.org/>

## 4 Principle

A test assembly comprising at least the first 1 m of chamber or manhole components, measured from, and including, any component or recommended installation assembly detail at the top end of the inspection chamber or manhole, is buried either in a soil box or under field conditions and a load is applied (see [Figure 1](#)).

During loading, the vertical displacement of the cover assembly is measured. After the test is finished, the test assembly is visually inspected and checked for defects.

The referring standard can require test conditions that differ from those set in this document for the following test parameters:

- a) the number of test pieces (see [Clause 6](#));
- b) the maximum load (see [Clause 9](#));
- c) the soil group of granular surround (see [Clause 9](#));
- d) the compaction of the granular surround (see [Clause 9](#)).

## 5 Apparatus

**5.1 Soil box**, large enough to accommodate at least the first 1 m of the test assembly and such that at all sides of the assembly a free space of 300 mm minimum is available. The box shall conform to the rigidity and other general requirements specified in ISO 13260.

**5.2 Loading device**, capable of applying the required load to the middle of the cover and of maintaining a constant load for a minimum of 15 min. The load shall be applied via a loading plate conforming to the requirements given in EN 124-1.

NOTE A loading device can comprise a hydraulic actuator; alternatively, the load can be applied using dead weight.

**5.3 Thermocouple**, capable of measuring temperature to an accuracy of  $\pm 5$  °C.

**5.4 Test assembly**, comprising at least the first 1 m of test assembly measured from, and including, the top assembly detail of the inspection chamber or manhole (see [Figures 1](#) and [2](#)).

[ISO 13266:2022](#)

<https://standards.iteh.ai/catalog/standards/sist/1d05170d-110d-474f-9796-cc4fdb96bf6/iso-13266-2022>

Dimensions in metres

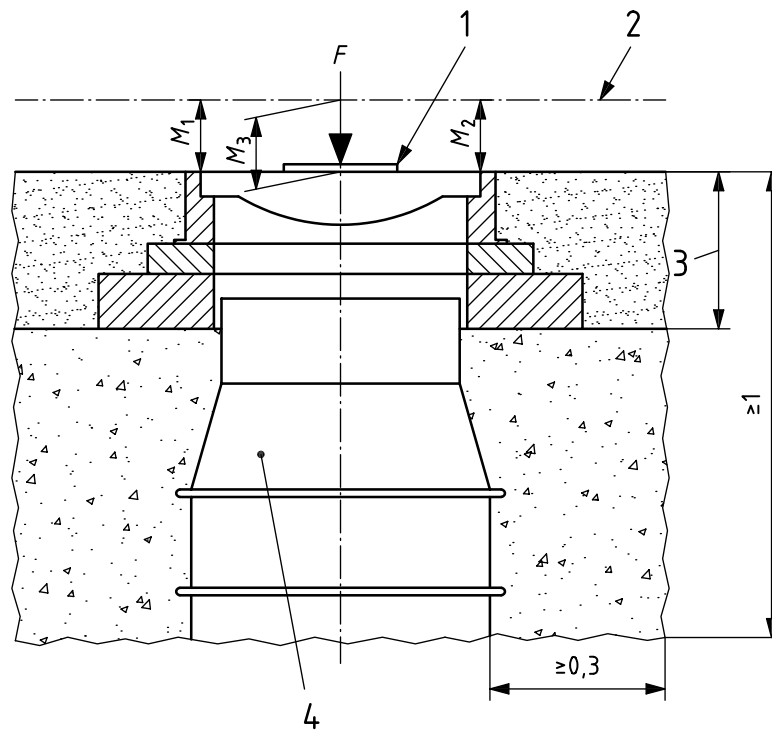

**Key**

- 1 loading plate, size in accordance with EN 124-1
  - 2 reference line, datum
  - 3 cover solution comprising at least cover and near surface components if applicable
  - 4 top element of chamber or manhole
- $F$  test load
- $M_1$ ,  $M_2$  and  $M_3$  dimensions for determining the displacement (see 8.2)

**Figure 1 — Test assembly**

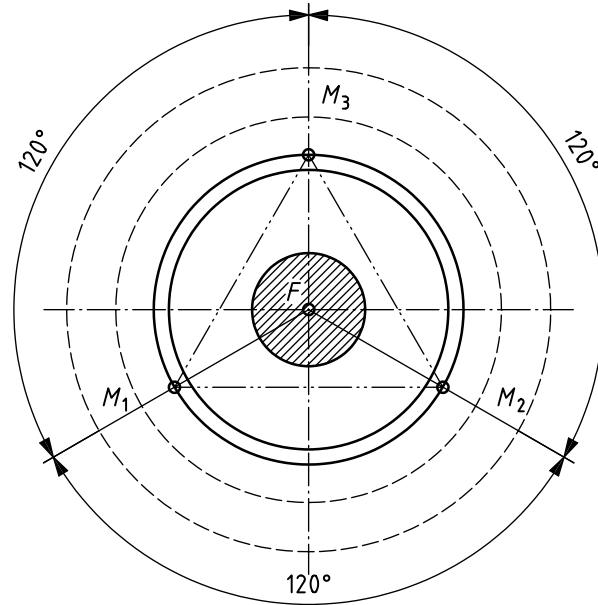

**Key**

- $F$  centre point of application of the test load
- $M_1, M_2$  and  $M_3$  points of measurement of displacements (see 8.2)

iTech STANDARD PREVIEW  
**Figure 2 — Position of measuring points**  
 (standards.iteh.ai)

**6 Number of test pieces**

Unless otherwise specified in the referring standard, the number of test pieces shall be one.

**7 Conditioning and test temperatures**

The test pieces shall not be tested for at least 24 h after manufacture.

The test shall be performed at ambient temperature between 5 °C and 25 °C. The test shall not be performed if the granular surround is at a temperature of less than 3 °C. The temperature of the granular surround shall be recorded.

**8 Procedure**

**8.1** Bury the test assembly (5.4) either in the soil box (5.1) or under field conditions using the test parameters given in Table 1, ensuring that there is at least 300 mm of specified granular surround conforming to Clause 9. Where the test assembly is to be buried in the field, excavate enough soil to accommodate at least the first metre of the riser shaft below the test assembly. Bury the thermocouple in the granular surround at the top of the riser shaft, but below the other assembly components, at a distance of approximately 300 mm.

Where the inspection chamber or manhole incorporates a pavement as an integral part of the cover, apply the pavement as in real practice and bury under field conditions.

Where telescopic adapters are supplied, install the support ring and covers in accordance with the manufacturer’s product or installation description.

Measure and record at the specified points the distance between the top of the cover and a reference line (datum) which will not be affected by the load (see Figure 1).



**8.2** Apply the load using the loading device (5.2) within a period of 1 min to 5 min and maintain at the maximum value specified in Table 1 for a minimum of 15 min. Having applied the load, re-measure and record the distances between the top of the cover and the datum. At the end of the test, when the load is still applied, the final distance between the top of the cover and the datum has to be re-measured and recorded again.

**8.3** After removal of the load, visually inspect the test assembly inspecting for cracks or defects likely to impair performance.

## 9 Test parameters

Unless otherwise specified in the referring system standard, the test parameters shall conform to Table 1.

**Table 1 — Test parameters**

Classification of inspection chamber or manhole <sup>a</sup>	Maximum load <sup>b</sup>	Soil group of granular surround <sup>c</sup>	Compaction of granular surround <sup>d</sup>
	kN		%
Class A	5	3	≤ 95
Class B	50	2	> 95 and ≤ 98
Class C	75	1	> 98
Class D	100	1	> 98
Class E	150	1	> 98

<sup>a</sup> The classification of the application shall be in accordance with EN 124-1.

<sup>b</sup> The maximum load is not to be confused with the test load for covers in EN 124 -1.

<sup>c</sup> The classification of soil group shall be in accordance with CEN/TS 1046. The soil group shall be as specified, unless otherwise specified in the minimum required installation condition of the manufacturer, in which case, the manufacturer's requirements shall apply.

<sup>d</sup> Unless otherwise specified in the minimum required installation condition of the manufacturer, in which case, the manufacturer's requirements shall apply.

## 10 Test report

The test report shall include at least the following information:

- a reference to this document, i.e. ISO 13266:2022 and the referring standard;
- a detailed identification of the inspection chamber or manhole components tested sufficient for factory process control requirements;
- the installation details used during the test and their relationship to the recommended details of the manufacturer;
- the test procedure used;
- the soil temperature;
- the maximum load;
- the measured displacement(s);
- the test duration time;
- after testing, any observed crack(s) and other defects likely to impair the performance of the inspection chamber or manhole;

- j) any factors that could have affected the result, such as any incidents or any operating details not specified in this document and any deviations from the procedure;
- k) any unusual features observed;
- l) the date of test.

**iTeh STANDARD PREVIEW**  
**(standards.iteh.ai)**

ISO 13266:2022

<https://standards.iteh.ai/catalog/standards/sist/1d05170d-110d-474f-9796-cc4fdbe96bf6/iso-13266-2022>