

INTERNATIONAL
STANDARD

ISO
11617

Second edition

**Building and civil engineering
sealants — Determination of changes
in cohesion and appearance of
elastic weatherproofing sealants
after exposure of statically cured
specimens to artificial weathering and
mechanical cycling**
(standards.iteh.ai)

[ISO/PRF 11617](https://standards.iteh.ai/catalog/standards/sist/ba6b173c-eb99-4d96-8030-7f5c50cba33f/iso-prf-11617)

<https://standards.iteh.ai/catalog/standards/sist/ba6b173c-eb99-4d96-8030-7f5c50cba33f/iso-prf-11617>

PROOF / ÉPREUVE



Reference number
ISO 11617:2021(E)

© ISO 2021

iTeh STANDARD PREVIEW (standards.iteh.ai)

ISO/PRF 11617

<https://standards.iteh.ai/catalog/standards/sist/ba6b173c-eb99-4d96-8030-7f5c50cba33f/iso-prf-11617>



COPYRIGHT PROTECTED DOCUMENT

© ISO 2021

All rights reserved. Unless otherwise specified, or required in the context of its implementation, no part of this publication may be reproduced or utilized otherwise in any form or by any means, electronic or mechanical, including photocopying, or posting on the internet or an intranet, without prior written permission. Permission can be requested from either ISO at the address below or ISO's member body in the country of the requester.

ISO copyright office
CP 401 • Ch. de Blandonnet 8
CH-1214 Vernier, Geneva
Phone: +41 22 749 01 11
Email: copyright@iso.org
Website: www.iso.org

Published in Switzerland

Contents

	Page
Foreword.....	iv
1 Scope	1
2 Normative references	1
3 Terms and definitions	1
4 Principle	1
5 Apparatus	2
5.1 Support.....	2
5.2 Spacers.....	2
5.3 Backing material (bond breaker).....	3
5.4 Separators.....	3
5.5 Container.....	4
5.6 Ventilated convection-type oven.....	4
5.7 Fully automated test chamber with an artificial light source.....	4
5.8 Artificial light source.....	4
5.8.1 General.....	4
5.8.2 Xenon-arc light source (default).....	5
5.8.3 Fluorescent ultraviolet source (option).....	5
5.8.4 Open-flame carbon arc source (option).....	5
5.9 Black standard (insulated) and black panel (uninsulated) temperature sensors.....	5
5.10 Measuring tools.....	5
6 Preparation of test specimens	5
7 Conditioning	6
7.1 General.....	6
7.2 Method A (default).....	6
7.3 Method B (option).....	6
8 Test conditions	6
8.1 Test conditions of artificial weathering.....	6
8.1.1 Test conditions of xenon-arc lamps device.....	6
8.1.2 Test conditions of fluorescent UV lamps device.....	7
8.1.3 Test conditions of open-flame carbon arc lamps device.....	7
8.2 Mechanical cycling.....	8
8.3 Degradation cycles.....	8
9 Test procedure	8
10 Examination for defects	9
10.1 General.....	9
10.2 Sections through sealant test specimen.....	9
10.3 Rating for cohesive cracks in zone C.....	10
11 Photo documentation of test specimens	12
12 Test report	13
Annex A (informative) Engineering drawing of anodized aluminium support assembly	15
Annex B (informative) The reference size of the separator	16
Bibliography	18

Foreword

ISO (the International Organization for Standardization) is a worldwide federation of national standards bodies (ISO member bodies). The work of preparing International Standards is normally carried out through ISO technical committees. Each member body interested in a subject for which a technical committee has been established has the right to be represented on that committee. International organizations, governmental and non-governmental, in liaison with ISO, also take part in the work. ISO collaborates closely with the International Electrotechnical Commission (IEC) on all matters of electrotechnical standardization.

The procedures used to develop this document and those intended for its further maintenance are described in the ISO/IEC Directives, Part 1. In particular, the different approval criteria needed for the different types of ISO documents should be noted. This document was drafted in accordance with the editorial rules of the ISO/IEC Directives, Part 2 (see www.iso.org/directives).

Attention is drawn to the possibility that some of the elements of this document may be the subject of patent rights. ISO shall not be held responsible for identifying any or all such patent rights. Details of any patent rights identified during the development of the document will be in the Introduction and/or on the ISO list of patent declarations received (see www.iso.org/patents).

Any trade name used in this document is information given for the convenience of users and does not constitute an endorsement.

For an explanation of the voluntary nature of standards, the meaning of ISO specific terms and expressions related to conformity assessment, as well as information about ISO's adherence to the World Trade Organization (WTO) principles in the Technical Barriers to Trade (TBT), see www.iso.org/iso/foreword.html.

This document was prepared by Technical Committee ISO/TC 59, *Buildings and civil engineering works*, Subcommittee SC 8, *sealants*.

This second edition cancels and replaces the first edition (ISO 11617:2014), which has been technically revised.

The main changes are as follows:

- this document has been updated and restructured for easier access to the relevant information.

Any feedback or questions on this document should be directed to the user's national standards body. A complete listing of these bodies can be found at www.iso.org/members.html.

Building and civil engineering sealants — Determination of changes in cohesion and appearance of elastic weatherproofing sealants after exposure of statically cured specimens to artificial weathering and mechanical cycling

1 Scope

This document specifies laboratory exposure procedures for determining the effects of cyclic movement and artificial weathering on cured, elastic weatherproofing joint sealants (one- or multi-component).

2 Normative references

The following documents are referred to in the text in such a way that some or all of their content constitutes requirements of this document. For dated references, only the edition cited applies. For undated references, the latest edition of the referenced document (including any amendments) applies.

ISO 4892-1:2016, *Plastics — Methods of exposure to laboratory light sources — Part 1: General guidance*

ISO 4892-2:2013, *Plastics — Methods of exposure to laboratory light sources — Part 2: Xenon-arc lamps*

ISO 4892-3:2016, *Plastics — Methods of exposure to laboratory light sources — Part 3: Fluorescent UV lamps*

ISO 4892-4:2013, *Plastics — Methods of exposure to laboratory light sources — Part 4: Open-flame carbon-arc lamps*

ISO 6927, *Building and civil engineering sealants — Vocabulary*

CIE 085-1989, *Solar spectral irradiance*

3 Terms and definitions

For the purposes of this document, the terms and definitions given in ISO 6927 apply.

ISO and IEC maintain terminology databases for use in standardization at the following addresses:

- ISO Online browsing platform: available at <https://www.iso.org/obp>
- IEC Electropedia: available at <https://www.electropedia.org/>

4 Principle

Test specimens are prepared in which the sealant to be tested adheres to two parallel support surfaces (substrates). The specimens are conditioned statically (no movement) in a controlled climate. The conditioned specimens (in their extended/compressed state) are exposed to repetitive degradation cycles of artificial weathering (light, heat and moisture) and cyclic movement under controlled environmental conditions. Within each cycle, weathering is carried out for six weeks in an artificial weathering machine. After completion of each degradation cycle (each lasting six weeks), the specimens (in their extended/compressed state) are visually examined for changes in appearance, cohesion and adhesion of the sealant beads. The rating for quantity, width and depth of cohesive cracks for a specific extension/compression value achieved along the length of the specimen as well as the depth, length and range of any very significant loss of cohesion or adhesion (defined as > 3 mm crack depth) is determined; and the general condition of the sealant is reported. The weathering and mechanical cycling exposure

and the examination for failures constitute a degradation cycle; and the degradation cycle is repeated 3 times (default value) or repeated as often as desired to achieve a certain exposure.

5 Apparatus

5.1 Support

Anodized aluminium support (as shown in [Figure 1](#)) for the preparation of test specimens, consisting of two pivoting, L-shaped anodized aluminium support elements of 2 mm thickness riveted onto an anodized aluminium base-plate of 2 mm thickness such that a cavity of dimensions 120 mm × 20 mm × 18 mm (length × width × height) is formed.

Riveting of the support elements on the base-plate shall be such that they can be turned freely with minimal friction on the pivot (fulcrum). The base plate holds five (5) equally spaced holes of 5 mm diameter (for improved ventilation of the back face of the sealant such as to ensure better cure or drying of the sealant) and two 3 mm holes for fixation of the specimen (see [Figure 1](#) and [Annex A](#)). For the specification of the anodized aluminium, refer to ISO 13640. All surfaces of the anodized aluminium support to be later in contact with the sealant should be cleaned according to the sealant manufacturer's recommendation.

Achieving optimum adhesion on the support substrate is important in order to obtain reproducible ratings for surface and bulk degradation (cracking, crazing, cohesive failure, etc.) that is induced or influenced by mechanical cycling. Even a partial loss of adhesion causes a section of the test specimen to be exposed to no or a lower degree of mechanical cycling than intended for a given movement amplitude of the sealant and invalidate the results obtained for this movement exposure (as assessed along the extended leg of the test specimen). Currently, no cleaning procedure and cleaning agent(s) have been identified that provide optimum adhesion on the support substrate for all sealant products. Therefore, no cleaning procedure is specified in this document. If the manufacturer does not provide a recommendation for the cleaning procedure, the following method is suggested for consideration by the experimenter. Clean all surfaces of the anodized aluminium support to be later in contact with the sealant with high purity acetone (purity, by gas chromatography: 998 g/kg) as follows:

- a) saturate a clean, lint-free paper tissue or cloth with the solvent;
- b) clean the substrate with the solvent-saturated cloth or tissue by wiping a minimum of three times so that visible contamination cannot be observed;
- c) wipe the substrate with solvent-saturated cloth or tissue and immediately afterwards dry wipe the substrate surface thoroughly using a dry, clean, lint-free paper tissue or cloth before the solvent completely evaporates.

Repeat step c) at least once. In each wipe of the substrate surface during step c), a new, uncontaminated cloth or tissue should be used. For severely contaminated substrates, additional pre-cleaning steps may be required.

If other support materials are to be used, they should be characterised and described in the test report. If other support dimensions are used, they should be described in the test report.

5.2 Spacers

Spacers for the preparation of the specimens, of dimensions 20 mm × 18 mm × 10 mm, with anti-adherent surface (see [Figure 1](#)), shall be used. If the spacers are made of material to which the sealant adheres, their surface shall be made anti-adherent, e.g. by a thin wax coating.

Dimensions in millimetres

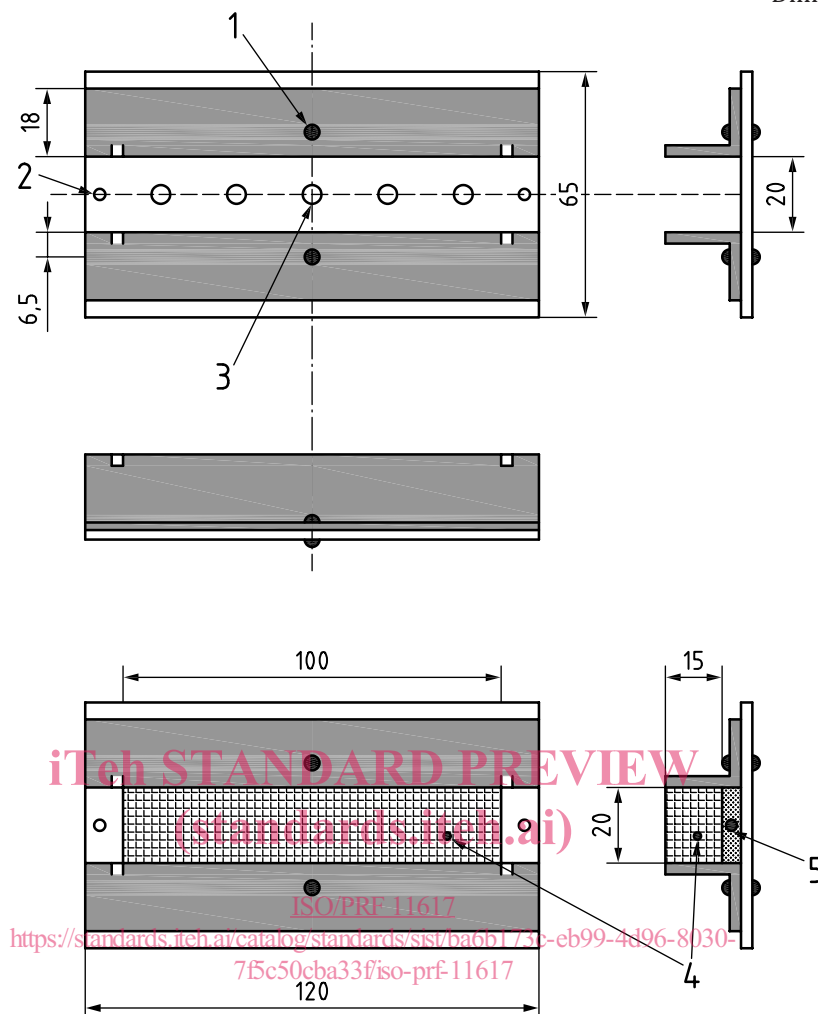
**Key**

- 1 rivet
- 2 3 mm \varnothing hole (for fixing)
- 3 5 mm \varnothing hole (for ventilation)
- 4 sealant
- 5 3 mm PE or PU open-cell foam

NOTE Sealant in anodised aluminium support is exposed to cyclic mechanical movement of sealant.

Figure 1 — Schematic drawing of test specimen

5.3 Backing material (bond breaker)

Open-cell foam backing material [polyethylene (PE) or polyurethane (PU) foam] of 3 mm thickness for the preparation of test specimens shall be used. The foam backing material shall not restrict the movement of the L-shaped pivoted support elements.

5.4 Separators

Separators, of appropriate dimensions, shall be used to hold the test specimens in extension up to the maximum specified movement amplitude of the sealant (see [Annex B](#)).

5.5 Container

Container filled with demineralised or distilled water shall be used for conditioning according to method B (see 7.3).

5.6 Ventilated convection-type oven

Ventilated convection-type oven, capable of being maintained at (70 ± 2) °C, shall be used for conditioning according to method B (see 7.3).

5.7 Fully automated test chamber with an artificial light source

Fully automated test chamber with an artificial light source (see 5.8) shall be used, capable of exposing the test specimens to radiation under controlled conditions of temperature, relative humidity and water, conforming to the requirements of the ISO 4892 series. The radiation is always directed towards the same surface of the sealant specimen. Standard practices for operating such accelerated weathering chambers are described in ISO 4892-1.

In fully automated test equipment, exposure to water for this test method is accomplished by water spraying the specimen surface or immersing the test specimens in water^{1),2),3)}. Contamination of the water shall be avoided. The purity of the water to be used is described in ISO 4892-1.

In the immersion technique, the test specimens are placed in a chamber that is periodically flooded with re-circulated water. During immersion, the specimens are completely covered by water. The water temperature is measured below the water surface with the black standard thermometer. The immersion system shall be made from corrosion-resistant materials that do not contaminate the water employed.

5.8 Artificial light source

[ISO/PRF 11617](https://standards.iteh.ai/catalog/standards/sist/ba6b173c-eb99-4d96-8030-7f5c50cba33f/iso-prf-11617)

<https://standards.iteh.ai/catalog/standards/sist/ba6b173c-eb99-4d96-8030-7f5c50cba33f/iso-prf-11617>

5.8.1 General

Light sources for the simulation of the global radiation at the surface of the earth are subject to development. The degree of approximation to the spectral power distribution according to CIE 085-

1) Adequate heat transfer between the test specimen and the environment is essential during the lower temperature period in the fluorescent UV/condensation device in order for condensation on the sealant to occur. This places restrictions on the thermal mass and, consequently, on the dimensions of a specimen. No experimental data have been generated on the time-of-wetness of sealant test specimens of the kind specified in this document when placed in fluorescent UV/condensation device operating at conditions specified in this document. However, testing conducted by ASTM C24 on ISO 8339 specimens appears to suggest that the condensation process provided in the fluorescent UV/condensation apparatus is generally not applicable to the type of sealant specimens tested. Therefore, wetting in this document is carried out by water spray on the exposed specimen surface (default method). However, the front surface water spray accessory was not designed for this purpose and requires an unreasonable amount of pure water for the wet period specified. Therefore, often the equipment is modified to allow re-circulation of the water during the exposure period. Some fluorescent UV equipment has adaptable spray manifolds, which allow installation of lower flow type nozzles, thus reducing the amount of pure water used.

2) Data generated with these two methods of water exposure (spray or immersion) in a interlaboratory test on a set of sealants for revision of ISO 11431 showed acceptable correlation, although contributions to the various degradation mechanisms acting in the specimens (e.g. hydrolysis, thermal shock, leaching of formulation components) can differ between these exposures. The degree of correlation between these two methods thus can vary depending on the specific sealant tested.

3) Spray water can be fresh or re-circulated from a holding tank. Immersion water is generally in a holding tank for re-circulation. The temperature of the spray water is uncontrolled and for fresh water is typically (21 ± 5) °C. Recirculated spray water can be at a higher temperature. The uncontrolled temperature of the re-circulated immersion water during operation of the weathering device is typically (40 ± 5) °C. It can be controlled by heating the water to a higher temperature. However, heating is not desirable because the water immersion temperature would then differ to a larger extent from the spray water temperature.

1989, Table 4 depends on the type of lamp. Xenon-arc lamps with suitable filters are preferred and are considered the default for the purpose of this document.

Several factors can change the intensity and the spectral power distribution of the artificial light source during service. Follow the manufacturer's recommendations and the requirements of the ISO 4892 series to maintain constant irradiation conditions.

5.8.2 Xenon-arc light source (default)

Xenon-arc light source with daylight filters shall be used for the simulation of terrestrial daylight as defined in the CIE 085. The spectral power distribution of the radiation shall conform to the requirements outlined in ISO 4892-2:2013, Table 1.

5.8.3 Fluorescent ultraviolet source (option)

Fluorescent UVA-340 lamp(s) shall be used. The radiation of UVA-340 lamp(s) is mainly in the ultraviolet region between 300 nm and 360 nm with negligible visible and infrared radiation. The spectral power distribution of the radiation shall conform to the requirements outlined in ISO 4892-3:2016, Table 1.

5.8.4 Open-flame carbon arc source (option)

Open-flame carbon arc light sources typically use carbon rods, which contain a mixture of metal salts. An electric current is passed between the carbon rods, which burn and give off ultraviolet, visible, and infrared radiation. Use carbon rods recommended by the device manufacturer. Open-flame carbon arc light source with daylight type filter (type 1 filter) is used. The spectral power distribution of the radiation shall conform to the requirements outlined in ISO 4892-4:2013, Table 1⁴⁾.

5.9 Black standard (insulated) and black panel (uninsulated) temperature sensors

Black standard (default) and black panel thermometer (option) temperature sensors shall conform to the requirements outlined in ISO 4892-1:2016, 5.2. The default thermometer is the black standard thermometer.

NOTE Under given operation conditions, black panel (uninsulated) thermometers tend to indicate lower temperatures than the black standard (insulated) thermometers. The temperature difference between the two types ranges between 3 °C and 12 °C, being smaller at lower irradiance levels.

The thermometer shall be mounted on the specimen rack so that its surface is in the same relative position and subjected to the same influences as the test specimens. Readings shall only be taken after sufficient time has elapsed for the temperature to become constant.

5.10 Measuring tools

Various tools for the determination of crack depth and width are commercially available, which are often used in the study of corrosion-induced pitting and cracking, for example, measuring microscope, digital optical micrometre, and digital pit and crack depth gauges.

6 Preparation of test specimens

Three test specimens for each sealant and each aging method shall be prepared.

Bring the sealant to (23 ± 2) °C before preparation of the specimens (this is generally achieved by conditioning the packaged sealant for 24 h at this temperature). Prepare three specimens. For each specimen, assemble one support (5.1), see Figure 1, by inserting two spacers (5.2) at the ends of the joint. Apply the open-cell backing foam (5.3) to the bottom of the joint.

4) The chemical composition of the carbon rods can affect the spectral power distribution of open flame carbon arc light sources.

Follow the instructions of the sealant manufacturer concerning the sealant application, for instance, whether a primer is to be used on the contact surface of the L-shaped support elements.

Fill the hollow volume (dimensions: width × depth × length = 20 mm × 15 mm × 100 mm) formed by the support, the backing foam and spacers with the sealant, while taking the following precautions:

- a) avoid the formation of air bubbles;
- b) press the sealant to the inner surfaces of the pivoted support elements;
- c) trim the sealant surface so that it is flush with the faces of the support elements and spacers;

After preparation, the sealant test specimens shall be examined for defects. Any test specimens deemed unsuitable for testing shall be rejected.

7 Conditioning

7.1 General

Condition the specimens at rest (static conditioning) in accordance with method A (default) or method B (option), as agreed between the parties concerned.

7.2 Method A (default)

Place the specimens such that air can freely circulate to the back-face of the base-plate. Condition the specimens, with the spacers in place, for 28 days at (23 ± 2) °C and (50 ± 10) % relative humidity. After the conditioning, remove the spacers at both sides of the sealant joint.

7.3 Method B (option)

Condition the specimens first according to method A. Then subject them three times to the following conditioning cycle:

- a) 3 days in the oven (5.6) at (70 ± 2) °C;
- b) 1 day in distilled water at (23 ± 2) °C;
- c) 2 days in the oven (5.6) at (70 ± 2) °C;
- d) 1 day in distilled water at (23 ± 2) °C.

This cycle may be carried out alternatively in the sequence c) – d) – a) – b). After the conditioning, remove the spacers at both sides of the sealant joint.

NOTE Conditioning B is a normal conditioning method using the influence of water and heat to accelerate the cure of the sealant. It is not intended to give information on the durability of the sealant.

8 Test conditions

8.1 Test conditions of artificial weathering

8.1.1 Test conditions of xenon-arc lamps device

Xenon-arc lamps with daylight filters are preferred. The test conditions of xenon-arc lamps device are in [Table 1](#).

Table 1 — Test conditions of xenon-arc lamps device

Exposures using daylight filters					
Exposure period	Irradiance		Black standard temperature °C	Chamber temperature °C	Relative humidity %
	300 nm to 400 nm, W/m ²	340 nm W/(m ² ·nm)			
102 min dry	60 ± 2	0,51 ± 0,02	65 ± 3	38 ± 3	50 ± 10
18 min water spray	60 ± 2	0,51 ± 0,02	-	-	-

Alternative exposure cycles as appropriate and agreed amongst the parties concerned may be used. However, if the experimenter deviates from the default values specified, both the default values as well as the actual conditions used shall be reported.

NOTE 1 The temperature of the spray water is typically (21 ± 5) °C.

NOTE 2 The cycles of dry and wet exposures are repeated 504 times (default) (six weeks total duration in the weathering machine).

8.1.2 Test conditions of fluorescent UV lamps device

UVA-340 lamps shall be used in fluorescent UV lamps device. The test conditions of fluorescent UV lamps device are in [Table 2](#).

Table 2 — Test conditions of fluorescent UV lamps device

Exposure period	Lamp type	Irradiance at 340 nm W/(m ² ·nm)	Black standard temperature °C
8 h dry	UVA-340	0,89	65 ± 3
4 h water spray	UVA-340	0,89	-

Alternative exposure cycles as appropriate and agreed amongst the parties concerned may be used. However, if the experimenter deviates from the default values specified, both the default values as well as the actual conditions used shall be reported.

NOTE 1 The temperature of the spray water is typically (21 ± 5) °C.

NOTE 2 The cycles of dry and wet exposures are repeated 84 times (default) (six weeks total duration in the weathering machine).

8.1.3 Test conditions of open-flame carbon arc lamps device

Open-flame arc lamps with daylight filters are used. The test conditions of open-flame carbon arc lamps device are in [Table 3](#).

Table 3 — Test conditions of Open-flame carbon arc lamps device

Exposure period	Radiation	Black standard temperature °C	Chamber temperature °C	Relative humidity %
102 min dry	continuous radiation	65 ± 3	40 ± 3	50 ± 10
18 min water spray		-	-	-

Alternative exposure cycles as appropriate and agreed amongst the parties concerned may be used. However, if the experimenter deviates from the default values specified, both the default values as well as the actual conditions used shall be reported.

NOTE 1 The temperature of the spray water is typically (21 ± 5) °C.

NOTE 2 The cycles of dry and wet exposures are repeated 504 times (default) (six weeks total duration in the weathering machine).