**Rubber, vulcanized or
thermoplastic — Accelerated ageing
and heat resistance tests**

*Caoutchouc vulcanisé ou thermoplastique — Essais de résistance au
vieillissement accéléré et à la chaleur*

iTeh STANDARD PREVIEW
(standards.iteh.ai)

ISO 188:2023

<https://standards.iteh.ai/catalog/standards/sist/925c3d11-1c07-42d3-99af-87ec9189346b/iso-188-2023>



iTeh STANDARD PREVIEW (standards.iteh.ai)

ISO 188:2023

<https://standards.iteh.ai/catalog/standards/sist/925c3d11-1c07-42d3-99af-87ec9189346b/iso-188-2023>



COPYRIGHT PROTECTED DOCUMENT

© ISO 2023

All rights reserved. Unless otherwise specified, or required in the context of its implementation, no part of this publication may be reproduced or utilized otherwise in any form or by any means, electronic or mechanical, including photocopying, or posting on the internet or an intranet, without prior written permission. Permission can be requested from either ISO at the address below or ISO's member body in the country of the requester.

ISO copyright office
CP 401 • Ch. de Blandonnet 8
CH-1214 Vernier, Geneva
Phone: +41 22 749 01 11
Email: copyright@iso.org
Website: www.iso.org

Published in Switzerland

Contents

Page

Foreword.....	iv
Introduction.....	v
1 Scope.....	1
2 Normative references.....	1
3 Terms and definitions.....	1
4 Principle.....	1
4.1 General.....	1
4.2 Accelerated ageing test.....	1
4.3 Heat resistance test.....	2
5 Apparatus.....	2
6 Calibration.....	6
7 Test pieces.....	6
8 Time interval between vulcanization and testing.....	7
9 Ageing conditions (duration and temperature).....	7
9.1 General.....	7
9.2 Accelerated ageing test.....	7
9.3 Heat resistance test.....	7
10 Procedure.....	8
11 Expression of results.....	8
12 Precision.....	8
13 Test report.....	8
Annex A (informative) Determination of the air speed inside the ovens with forced air circulation.....	10
Annex B (informative) Precision.....	12
Annex C (informative) Guidance for using precision results.....	19
Annex D (normative) Calibration schedule.....	20
Bibliography.....	22

Foreword

ISO (the International Organization for Standardization) is a worldwide federation of national standards bodies (ISO member bodies). The work of preparing International Standards is normally carried out through ISO technical committees. Each member body interested in a subject for which a technical committee has been established has the right to be represented on that committee. International organizations, governmental and non-governmental, in liaison with ISO, also take part in the work. ISO collaborates closely with the International Electrotechnical Commission (IEC) on all matters of electrotechnical standardization.

The procedures used to develop this document and those intended for its further maintenance are described in the ISO/IEC Directives, Part 1. In particular, the different approval criteria needed for the different types of ISO documents should be noted. This document was drafted in accordance with the editorial rules of the ISO/IEC Directives, Part 2 (see www.iso.org/directives).

Attention is drawn to the possibility that some of the elements of this document may be the subject of patent rights. ISO shall not be held responsible for identifying any or all such patent rights. Details of any patent rights identified during the development of the document will be in the Introduction and/or on the ISO list of patent declarations received (see www.iso.org/patents).

Any trade name used in this document is information given for the convenience of users and does not constitute an endorsement.

For an explanation of the voluntary nature of standards, the meaning of ISO specific terms and expressions related to conformity assessment, as well as information about ISO's adherence to the World Trade Organization (WTO) principles in the Technical Barriers to Trade (TBT), see www.iso.org/iso/foreword.html.

This document was prepared by Technical Committee ISO/TC 45, *Rubber and rubber products*, Subcommittee SC 2, *Testing and analysis*.

This sixth edition cancels and replaces the fifth edition (ISO 188:2011), which has been technically revised.

The main changes are as follows:

- add oven type with a forced air circulation and high air speed/air exchange rate;
- editorial changes for better understanding.

Any feedback or questions on this document should be directed to the user's national standards body. A complete listing of these bodies can be found at www.iso.org/members.html.

Introduction

Accelerated ageing and heat resistance tests are used to determine the change of defined properties of rubber and thermoplastic elastomers over a specified period. These properties are compared before and after the accelerated ageing and heat resistance tests.

In accelerated ageing, the rubber is exposed to an elevated temperature with the intention to simulate the effect of natural ageing in a shorter time. The degree of acceleration depends on the tested material as well as to the property being evaluated.

In the case of heat resistance tests, the rubber is exposed to prolonged periods at the operation temperature of the material.

Two types of ovens are specified in this document, cell ovens and cabinet ovens. Cabinet ovens can be of four types as described in [Clause 5](#).

The duration, temperature, and atmosphere to which the test pieces are exposed and the type of oven to use depends on the purpose of the test and the type of polymer.

The change of properties not only depends on the temperature but can also depend on the air speed. Consequently, even tests at the same temperature but at different air speed (different ovens) may give different results.

Consequences of these effects are

- a) accelerated ageing is only a simulation of the natural ageing and can therefore produce different results.
- b) If different materials are compared, it is recommended to perform the accelerated ageing tests at more than one elevated temperature as different rubbers might show a different temperature behaviour (change of properties) at certain operation temperatures.
- c) It is important to determine the properties of the rubber for the accelerated ageing test, which are used for the intended material application. Only these properties should be used for the evaluation of the test results. If these properties give a different ranking of the materials tested, it is recommended to agree on a lead property for evaluation. It is also recommended, that all evaluated properties are measured according to an international standard or an equivalent test procedure.

Air-oven ageing should not be used to simulate natural ageing under stress (bent or stretched test pieces) and the presence of light or ozone.

To estimate lifetime or maximum temperature of use, tests can be performed at several temperatures and the results can be evaluated by using an Arrhenius plot or the Williams Landel Ferry (WLF) equation as described in ISO 11346.

Rubber, vulcanized or thermoplastic — Accelerated ageing and heat resistance tests

WARNING — Persons using this document should be familiar with normal laboratory practice. This document does not purport to address all of the safety problems, if any, associated with its use. It is the responsibility of the user to establish appropriate safety and health practices and to determine the applicability of any other restrictions.

1 Scope

This document specifies accelerated ageing or heat resistance tests on vulcanized or thermoplastic rubbers/thermoplastic elastomers. Four methods are possible, they are detailed in [Clause 5](#).

2 Normative references

The following documents are referred to in the text in such a way that some or all of their content constitutes requirements of this document. For dated references, only the edition cited applies. For undated references, the latest edition of the referenced document (including any amendments) applies.

ISO 18899, *Rubber — Guide to the calibration of test equipment*

ISO 23529, *Rubber — General procedures for preparing and conditioning test pieces for physical test methods*

3 Terms and definitions

No terms and definitions are listed in this document.

ISO and IEC maintain terminology databases for use in standardization at the following addresses:

- ISO Online browsing platform: available at <https://www.iso.org/obp>
- IEC Electropedia: available at <https://www.electropedia.org/>

4 Principle

4.1 General

Test pieces are exposed to air at a given elevated temperature and at atmospheric pressure with controlled conditions of air circulation.

Physical properties are measured before and after exposure and the results compared.

The physical properties that are important for the intended application of the material should be used to determine the effects of exposure. In the absence of any indication of these properties, it is recommended that tensile strength, stress at intermediate elongation, elongation at break (in accordance with ISO 37) and hardness (in accordance with ISO 48-2) are measured.

4.2 Accelerated ageing test

Test pieces are subjected to a higher temperature than the rubber would experience in its intended application to simulate the effects of natural ageing in a shorter time.

4.3 Heat resistance test

Test pieces are subjected to the temperature they would experience in their intended application to gain information about their service performance.

5 Apparatus

5.1 Air oven.

The oven shall be of such a size that the total volume of the test pieces does not exceed 10 % of the free space in the oven. Provision shall be made for suspending test pieces so that they are at least 10 mm from each other and, in cabinet ovens and ovens with forced air circulation, at least 50 mm from the sides of the oven.

The temperature of the oven shall be controlled so that the temperature of the test pieces is kept within the specified tolerance for the specified ageing temperature (see [Clause 9](#)) for the whole ageing period. A temperature sensor shall be placed inside the heating chamber close to the test pieces to indicate the actual ageing temperature.

No copper or copper alloys shall be used in the construction of the heating chamber.

Method A: using a cell or cabinet oven with low air speed, laminar flow of air past the stationary test pieces and air exchange rate between 3 and 10 changes per hour.

Method B: using a cabinet oven with high air speed, laminar flow of air past the test pieces and air exchange rate between 3 and 10 changes per hour.

Method C: using a cabinet oven with high air speed, turbulent flow of air past the test pieces, rotation of the test piece carrier and air exchange rate between 3 and 10 changes per hour.

For method A, B and method C, provision shall be made for a slow flow of air through the oven of not less than three and not more than ten air changes per hour.

Method D: Using a cabinet oven with high air speed, turbulent flow of air past the stationary test pieces and air exchange rate greater than 30 changes per hour.

For method D, an air flow between 0,25 to 3,0 m/s is necessary as well as an air exchange rate above 30 changes per hour.

Depending on the influence of the air speed/air exchange on the results, to get comparable results always the same method should be used to compare the ageing behaviour of different materials.

The incoming air in the oven should be heated up to the temperature within a ± 1 °C tolerance before reaching the test pieces.

The ventilation (or air change rate) can be determined by measuring the volume of the oven chamber and the flow of air through the chamber.

NOTE To ensure a good precision when doing ageing and heat resistance tests, it is very important to keep the temperature uniform and stable within the oven and during the test. Therefore, it is necessary and to verify that the oven used, is within the temperature limits at all test piece locations and during the complete testing time. Increasing the air speed in the oven improves temperature homogeneity. However, air circulation in the oven and ventilation influences the ageing results. With a low air speed, accumulation of degradation products and evaporated ingredients, as well as oxygen depletion, can happen. A high air speed may increase the rate of deterioration, due to increased oxidation and migration of plasticizers and antioxidants.

NOTE Method D oven can be used for short term testing up to 168 h.

5.2 Method A cell oven.

The oven shall consist of one or more vertical cylindrical cells having a minimum height of 300 mm. The cells shall be surrounded by a thermostatically controlled good heat transfer medium (aluminium block, liquid bath, or saturated vapour). Air passing through one cell shall not enter other cells.

Provision shall be made for a slow flow of air through the cell. The air speed shall depend on the air change rate only.

5.3 Method A cabinet oven.

The oven should consist of a single chamber without separating walls. Provision shall be made for a slow flow of air through the oven. The air speed shall depend on the air change rate only, and no fans are allowed inside the test chamber.

5.4 Method B, C and D cabinet oven with forced air circulation.

One of the following three types shall be used:

- a) Method B cabinet oven with laminar air flow and forced air circulation (see [Figure 1](#)).

The air flow through the heating chamber shall be as uniform and laminar as possible. The test pieces shall be placed so that the smallest surface faces the air flow to avoid disrupting the air flow. The air speed shall be between 0,5 m/s and 1,5 m/s.

The air speed near the test pieces can be measured by means of an anemometer.

IT-1 STANDARD PREVIEW
(standards.iteh.ai)

ISO 188:2023

<https://standards.iteh.ai/catalog/standards/sist/925c3d11-1c07-42d3-99af-87ec9189346b/iso-188-2023>

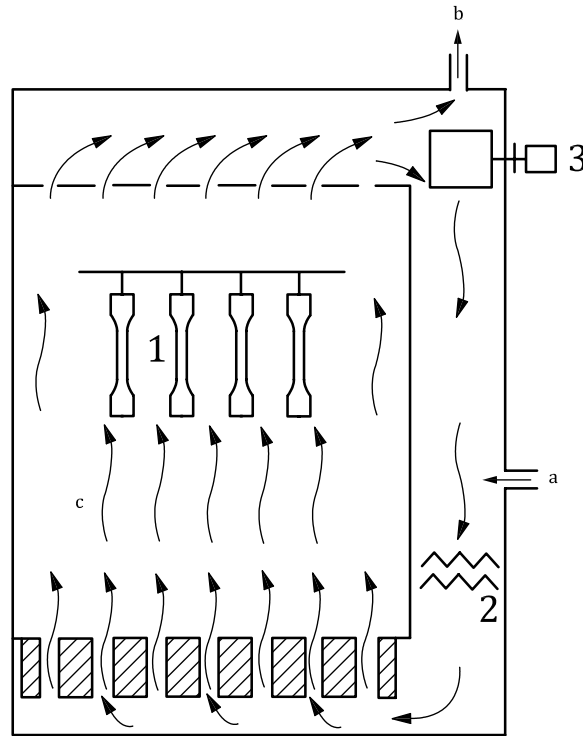

- Key**
- 1 test pieces
 - 2 heating element
 - 3 air blower
 - a Air inlet.
 - b Air outlet.
 - c Laminar air flow.

iTeh STANDARD PREVIEW
(standards.iteh.ai)

ISO 188:2023
<https://standards.iteh.ai/catalog/standards/sist/925c3d11-1c07-42d3-99af-87ec9189346b/iso-188-2023>

Figure 1 — Example of method B cabinet oven with laminar air flow

- b) Method C cabinet oven with forced air circulation, turbulent air flow and provision for rotating the test piece carrier (see [Figure 2](#)).

The air entering from a side-wall air-inlet into the heating chamber is turbulent around the test pieces, which are suspended on a carrier rotating at a speed of five to ten rotations per minute so that they are exposed to the heating air as uniformly as possible. The average air speed shall be $0,5 \text{ m/s} \pm 0,25 \text{ m/s}$.

The average air speed near the test pieces can be calculated from measurements made with an anemometer at nine different positions (see [Figure A.1](#)). A suitable method of measurement is described in [Annex A](#).

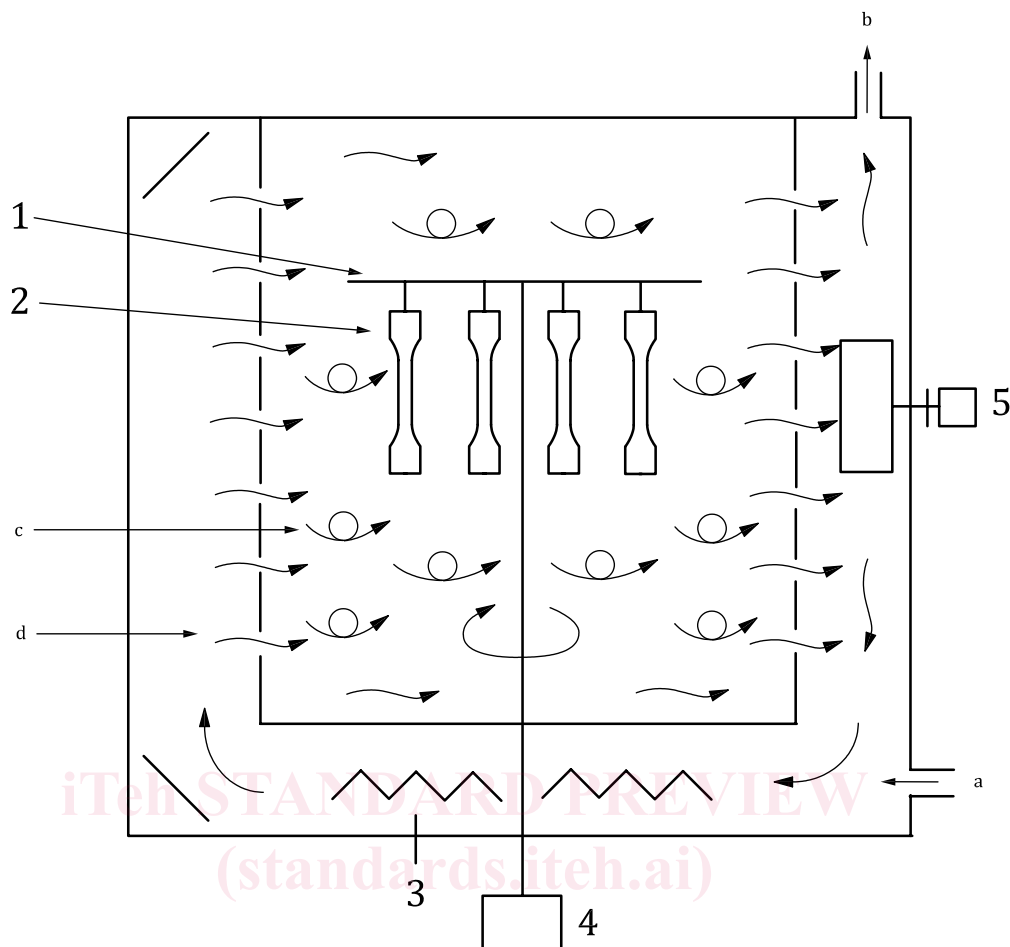
**Key**

- 1 test piece carrier
- 2 test pieces
- 3 heating element
- 4 motor
- 5 air blower
- a Air inlet.
- b Air outlet.
- c Turbulent air flow.
- d Laminar air flow (inlet, outlet and near to wall).

Figure 2 — Example of method C cabinet oven with turbulent air flow and provision for rotating the test piece carrier

- c) Method D cabinet oven with turbulent air flow (see [Figure 3](#)).

The air entering from a back-wall air-inlet into the heating chamber is turbulent around the test pieces, which are suspended inside the oven in such a way that they are exposed to the heating air as uniformly as possible. The average air speed shall be between 0,25 m/s and 3,0 m/s.

The average air speed near the test pieces can be calculated from measurements made with an anemometer at nine different positions (see [Figure A.1](#)). A suitable method of measurement is described in [Annex A](#).

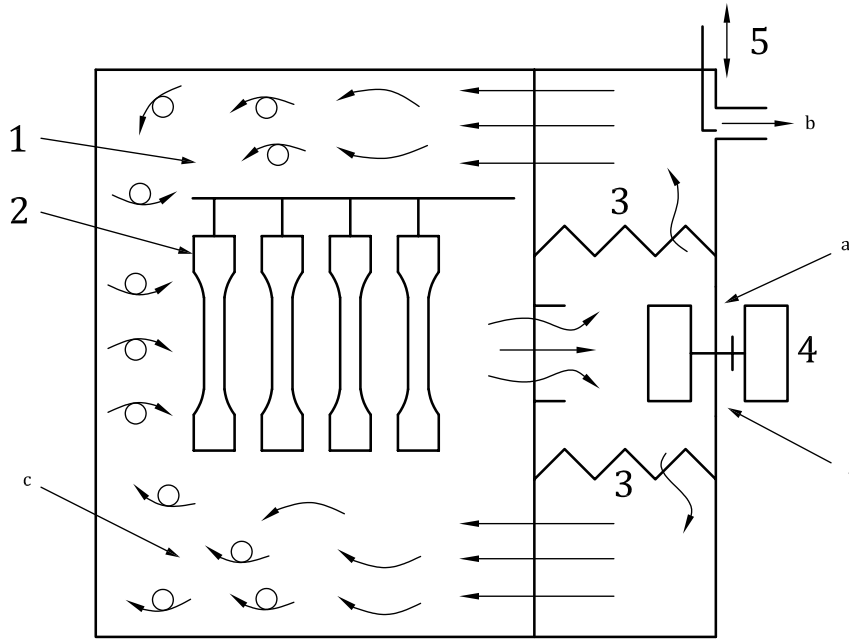

Key

- 1 test piece carrier
- 2 test pieces
- 3 heating element
- 4 air blower
- 5 regulator for air exchange rate
- a Air inlet.
- b Air outlet.
- c Turbulent air flow.

iTeh STANDARD PREVIEW
(standards.iteh.ai)

ISO 188:2023

<https://standards.iteh.ai/catalog/standards/sist/925c3d11-1c07-42d3-99af-87ec9189346b/iso-188-2023>

Figure 3 — Example of method D cabinet oven with turbulent air flow

NOTE The tolerances for method D are larger which makes it less suitable for exposures longer than 168 h.

6 Calibration

The test apparatus shall be calibrated in accordance with [Annex D](#).

7 Test pieces

Select and prepare the test pieces necessary for the tests to be carried out, in accordance with the requirements of ISO 23529.

Only test pieces of the same dimensions, having the same exposed areas shall be compared with each other. The number of test pieces shall be in accordance with the International Standard for the appropriate property tests.

The test pieces shall be capable of being identified after the test, for example by marking. Any method can be used that can withstand the exposure and does not affect the properties of the test piece or change the air flow.

NOTE Heat resistant tags attached with heat resistant string are satisfactory. Some marking inks can affect the ageing of the rubber or wear off during exposure.