**Industrial trucks — Verification of
stability —**

**Part 20:
Additional stability test for trucks
operating in the special condition of
offset load, offset by utilization**

Chariots de manutention — Vérification de la stabilité —

*Partie 20: Essai de stabilité supplémentaire pour les chariots
travaillant dans des conditions de gerbage spéciales avec une charge
déportée, déport par utilisation*

<https://standards.iteh.ai/catalog/standards/sist/2eccad93-5de0-4c94-95b1-bf7519d7b893/iso-22915-20-2023>



iTeh STANDARD PREVIEW (standards.iteh.ai)

ISO 22915-20:2023

<https://standards.iteh.ai/catalog/standards/sist/2eccad93-5de0-4c94-95b1-bf7519d7b893/iso-22915-20-2023>



COPYRIGHT PROTECTED DOCUMENT

© ISO 2023

All rights reserved. Unless otherwise specified, or required in the context of its implementation, no part of this publication may be reproduced or utilized otherwise in any form or by any means, electronic or mechanical, including photocopying, or posting on the internet or an intranet, without prior written permission. Permission can be requested from either ISO at the address below or ISO's member body in the country of the requester.

ISO copyright office
CP 401 • Ch. de Blandonnet 8
CH-1214 Vernier, Geneva
Phone: +41 22 749 01 11
Email: copyright@iso.org
Website: www.iso.org

Published in Switzerland

Contents

	Page
Foreword.....	iv
1 Scope.....	1
2 Normative references.....	1
3 Terms and definitions.....	2
4 Test conditions.....	3
4.1 General.....	3
4.2 Position of truck on the tilt table.....	3
4.2.1 Counterbalance trucks.....	3
4.2.2 Reach and straddle trucks.....	3
4.2.3 Pallet stackers.....	3
4.2.4 Bidirectional and multidirectional trucks.....	4
4.2.5 Counterbalanced container handler.....	4
4.2.6 Variable-reach container handler.....	4
4.2.7 Industrial variable-reach trucks.....	4
4.2.8 Rough-terrain trucks with mast.....	4
4.2.9 Rough-terrain variable reach trucks.....	4
4.2.10 Counterbalance trucks with articulated steering.....	4
4.2.11 Order-picking trucks with operator position elevating above 1 200 mm.....	4
4.2.12 Slewing variable-reach rough-terrain trucks.....	4
4.3 Position of the load.....	4
4.4 Lift height for trucks with attachments.....	4
5 Verification of stability.....	4
5.1 General.....	4
5.2 Counterbalance trucks.....	4
5.3 Reach and straddle trucks.....	5
5.4 Pallet stackers.....	5
5.5 Bidirectional and multidirectional trucks.....	5
5.6 Counterbalanced container handler.....	5
5.7 Industrial variable-reach trucks.....	5
5.8 Variable-reach container handler.....	5
5.9 Rough-terrain trucks with mast.....	5
5.10 Rough-terrain variable reach trucks.....	5
5.11 Counterbalance trucks with articulated steering.....	5
5.12 Order-picking trucks with operator position elevating above 1 200 mm.....	5
5.13 Slewing variable-reach rough-terrain trucks.....	5
6 Marking.....	5
Bibliography.....	6

Foreword

ISO (the International Organization for Standardization) is a worldwide federation of national standards bodies (ISO member bodies). The work of preparing International Standards is normally carried out through ISO technical committees. Each member body interested in a subject for which a technical committee has been established has the right to be represented on that committee. International organizations, governmental and non-governmental, in liaison with ISO, also take part in the work. ISO collaborates closely with the International Electrotechnical Commission (IEC) on all matters of electrotechnical standardization.

The procedures used to develop this document and those intended for its further maintenance are described in the ISO/IEC Directives, Part 1. In particular, the different approval criteria needed for the different types of ISO documents should be noted. This document was drafted in accordance with the editorial rules of the ISO/IEC Directives, Part 2 (see www.iso.org/directives).

Attention is drawn to the possibility that some of the elements of this document may be the subject of patent rights. ISO shall not be held responsible for identifying any or all such patent rights. Details of any patent rights identified during the development of the document will be in the Introduction and/or on the ISO list of patent declarations received (see www.iso.org/patents).

Any trade name used in this document is information given for the convenience of users and does not constitute an endorsement.

For an explanation of the voluntary nature of standards, the meaning of ISO specific terms and expressions related to conformity assessment, as well as information about ISO's adherence to the World Trade Organization (WTO) principles in the Technical Barriers to Trade (TBT), see www.iso.org/iso/foreword.html.

This document was prepared by Technical Committee ISO/TC 110, *Industrial trucks*, Subcommittee SC 2, *Safety of powered industrial trucks*.

This second edition cancels and replaces the first edition (ISO 22915-20:2008), which has been technically revised.

The main changes are as follows:

- references to “This part of ISO 22915” have been replaced by “this document”;
- the applicable types of trucks listed in the scope have been updated;
- cross-references to figures and tests from other parts of the ISO 22915 series have been dated;
- normative references in [Clause 2](#) have been updated;
- the Bibliography has been added;
- [Figure 1](#) has been updated to include a “CG” key reference, a line to CG and an adjusted load height; a key has been added.

A list of all parts in the ISO 22915 series can be found on the ISO website.

Any feedback or questions on this document should be directed to the user's national standards body. A complete listing of these bodies can be found at www.iso.org/members.html.

Industrial trucks — Verification of stability —

Part 20:

Additional stability test for trucks operating in the special condition of offset load, offset by utilization

1 Scope

This document specifies an additional test for verifying the stability of a laden truck whose utilization creates the special operating condition whereby the load centre of gravity is substantially offset from the truck's longitudinal centre plane or from the centred position by design.

A load is considered to be substantially offset if displaced by more than:

- 100 mm, for a truck with a rated capacity < 5 000 kg;
- 150 mm, for a truck with a rated capacity \geq 5 000 kg and \leq 10 000 kg;
- 250 mm, for a truck with a rated capacity > 10 000 kg and < 20 000 kg;
- 350 mm, for a truck with a rated capacity \geq 20 000 kg.

This document is applicable to the following types of trucks as defined in ISO 5053-1:

- a) counterbalance trucks;
- b) reach and straddle trucks;
- c) pallet stackers;
- d) bidirectional and multidirectional trucks;
- e) industrial variable-reach trucks;
- f) rough-terrain trucks with mast;
- g) rough-terrain variable reach trucks;
- h) counterbalance trucks with articulated steering;
- i) variable-reach container handler;
- j) counterbalanced container handler;
- k) order-picking truck;
- l) slewing rough-terrain variable-reach truck.

2 Normative references

The following documents are referred to in the text in such a way that some or all of their content constitutes requirements of this document. For dated references, only the edition cited applies. For undated references, the latest edition of the referenced document (including any amendments) applies.

ISO 3691-1, *Industrial trucks — Safety requirements and verification — Part 1: Self-propelled industrial trucks, other than driverless trucks, variable-reach trucks and burden-carrier trucks*

ISO 5053-1, *Industrial trucks — Vocabulary — Part 1: Types of industrial trucks*

ISO 22915-1:2016, *Industrial trucks — Verification of stability — Part 1: General*

ISO 22915-2:2018, *Industrial trucks — Verification of stability — Part 2: Counterbalanced trucks with mast*

ISO 22915-3:2021, *Industrial trucks — Verification of stability — Part 3: Reach and straddle trucks*

ISO 22915-4:2018, *Industrial trucks — Verification of stability — Part 4: Pallet stackers, double stackers and order-picking trucks with operator position elevating up to and including 1 200 mm lift height*

ISO 22915-7:2016, *Industrial trucks — Verification of stability — Part 7: Bidirectional and multidirectional trucks*

ISO 22915-9:2014, *Industrial trucks — Verification of stability — Part 9: Counterbalanced trucks with mast handling freight containers of 6 m (20 ft) length and longer*

ISO 22915-11:2011, *Industrial trucks — Verification of stability — Part 11: Industrial variable-reach trucks*

ISO 22915-12:2015, *Industrial trucks — Verification of stability — Part 12: Industrial variable-reach trucks handling freight containers of 6 m (20 ft) length and longer*

ISO 22915-13:2012, *Industrial trucks — Verification of stability — Part 13: Rough-terrain trucks with mast*

ISO 22915-14:2010, *Industrial trucks — Verification of stability — Part 14: Rough-terrain variable-reach trucks*

ISO 22915-15:2020, *Industrial trucks — Verification of stability — Part 15: Counterbalanced trucks with articulated steering*

ISO 22915-21:2019, *Industrial trucks — Verification of stability — Part 21: Order-picking trucks with operator position elevating above 1 200 mm*

ISO 22915-24:2015, *Industrial trucks — Verification of stability — Part 24: Slewing variable-reach rough-terrain trucks*

3 Terms and definitions

For the purposes of this document, the terms and definitions given in ISO 22915-1 and ISO 5053-1 and the following apply.

ISO and IEC maintain terminology databases for use in standardization at the following addresses:

- ISO Online browsing platform: available at <https://www.iso.org/obp>
- IEC Electropedia: available at <https://www.electropedia.org/>

3.1 special operating condition

stacking with load laterally offset from the longitudinal centre plane A-A, as defined in ISO 22915-1:2016, Figure 3, or from the centred position by design, offset by utilization

Note 1 to entry: See [Figure 1](#).

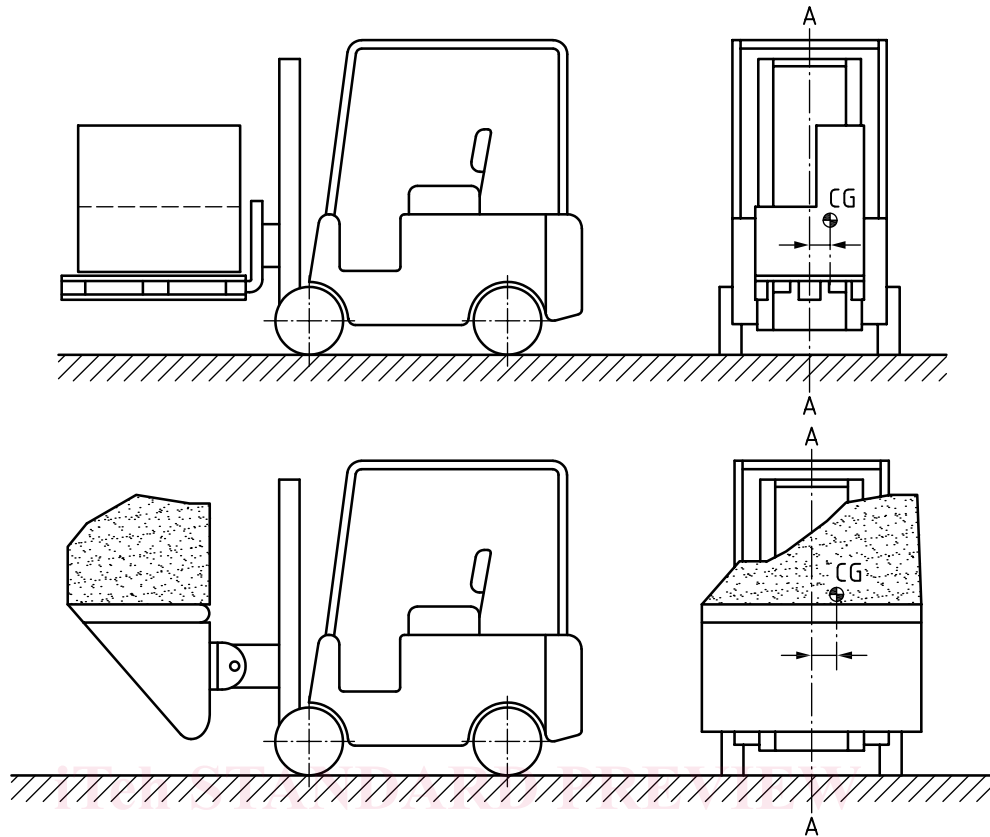
**Key**

A-A longitudinal centre plane

CG centre of gravity

ISO 22915-20:2023

<https://standards.iteh.ai/catalog/standards/sist/2eccad93-5de0-4c94-95b1->
Figure 1 — Examples of load offset by utilization**4 Test conditions****4.1 General**

See ISO 22915-1.

4.2 Position of truck on the tilt table**4.2.1 Counterbalance trucks**

The position of the truck on the tilt table shall be in accordance with test 3 of ISO 22915-2:2018.

4.2.2 Reach and straddle trucks

The position of the truck on the tilt table shall be in accordance with test 3 of ISO 22915-3:2021.

4.2.3 Pallet stackers

The position of the truck on the tilt table shall be in accordance with test 3 of ISO 22915-4:2018.

4.2.4 Bidirectional and multidirectional trucks

The position of the truck on the tilt table shall be in accordance with test 8 of ISO 22915-7:2016.

4.2.5 Counterbalanced container handler

The position of the truck on the tilt table shall be in accordance with test 3 of ISO 22915-9:2014.

4.2.6 Variable-reach container handler

The position of the truck on the tilt table shall be in accordance with test 3 of ISO 22915-12:2015.

4.2.7 Industrial variable-reach trucks

The position of the truck on the tilt table shall be in accordance with test 3 of ISO 22915-11:2011.

4.2.8 Rough-terrain trucks with mast

The position of the truck on the tilt table shall be in accordance with test 3 of ISO 22915-13:2012.

4.2.9 Rough-terrain variable reach trucks

The position of the truck on the tilt table shall be in accordance with test 3 of ISO 22915-14:2010.

4.2.10 Counterbalance trucks with articulated steering

The position of the truck on the tilt table shall be in accordance with test 3 of ISO 22915-15:2020.

4.2.11 Order-picking trucks with operator position elevating above 1 200 mm

The position of the truck on the tilt table shall be in accordance with test 3 of ISO 22915-21:2019.

4.2.12 Slewing variable-reach rough-terrain trucks

The position of the truck on the tilt table shall be in accordance with test 3 of ISO 22915-24:2015.

4.3 Position of the load

When conducting the test, the load shall be positioned in accordance with the requirements described in [Clause 5](#) and the centre of gravity of the load shall be offset laterally by the maximum amount it is anticipated will be encountered in actual operation.

4.4 Lift height for trucks with attachments

The lift height required for the test shall be according to ISO 22915-1:2016, 4.5.

5 Verification of stability

5.1 General

The stability of the truck shall be verified in accordance with the following subclauses, depending on the type of truck.

5.2 Counterbalance trucks

The stability shall be verified in accordance with test 3 of ISO 22915-2:2018.

5.3 Reach and straddle trucks

The stability shall be verified in accordance with test 3 of ISO 22915-3:2021.

5.4 Pallet stackers

The stability shall be verified in accordance with test 3 of ISO 22915-4:2018.

5.5 Bidirectional and multidirectional trucks

The stability shall be verified in accordance with test 8 of ISO 22915-7:2016.

5.6 Counterbalanced container handler

The stability shall be verified in accordance with test 3 of ISO 22915-9:2014.

5.7 Industrial variable-reach trucks

The stability shall be verified in accordance with test 3 of ISO 22915-11:2011.

5.8 Variable-reach container handler

The stability shall be verified in accordance with test 3 of ISO 22915-12:2015.

5.9 Rough-terrain trucks with mast

The stability shall be verified in accordance with test 3 of ISO 22915-13:2012.

5.10 Rough-terrain variable reach trucks

The stability shall be verified in accordance with test 3 of ISO 22915-14:2010.

5.11 Counterbalance trucks with articulated steering

The stability shall be verified in accordance with test 3 of ISO 22915-15:2020.

5.12 Order-picking trucks with operator position elevating above 1 200 mm

The stability shall be verified in accordance with test 3 of ISO 22915-21:2019.

5.13 Slewing variable-reach rough-terrain trucks

The stability shall be verified in accordance with test 3 of ISO 22915-24:2015.

6 Marking

The capacity under this special operating condition, as determined by this additional stability test, and the load offset shall be indicated on an information plate in view of the operator in the normal operating position according to ISO 3691-1.

Bibliography

- [1] ISO 22915-5, *Industrial trucks — Verification of stability — Part 5: Single-side-loading trucks*
- [2] ISO 22915-8, *Industrial trucks — Verification of stability — Part 8: Additional stability test for trucks operating in the special condition of stacking with mast tilted forward and load elevated*
- [3] ISO 22915-10, *Industrial trucks — Verification of stability — Part 10: Additional stability test for trucks operating in the special condition of stacking with load laterally displaced by powered devices*
- [4] ISO 22915-16, *Industrial trucks — Verification of stability — Part 16: Pedestrian-propelled trucks*
- [5] ISO 22915-17, *Industrial trucks — Verification of stability — Part 17: Towing tractors, burden and personnel carriers*
- [6] ISO 22915-22, *Industrial trucks — Verification of stability — Part 22: Lateral- and front-stacking trucks with and without elevating operator position*

iTeh STANDARD PREVIEW
(standards.iteh.ai)

[ISO 22915-20:2023](https://standards.iteh.ai/catalog/standards/sist/2eccad93-5de0-4c94-95b1-bf7519d7b893/iso-22915-20-2023)

<https://standards.iteh.ai/catalog/standards/sist/2eccad93-5de0-4c94-95b1-bf7519d7b893/iso-22915-20-2023>