



Designation: ~~D5450/D5450M-11~~ Designation: D5450/D5450M – 12

Standard Test Method for Transverse Tensile Properties of Hoop Wound Polymer Matrix Composite Cylinders¹

This standard is issued under the fixed designation D5450/D5450M; the number immediately following the designation indicates the year of original adoption or, in the case of revision, the year of last revision. A number in parentheses indicates the year of last reapproval. A superscript epsilon (ϵ) indicates an editorial change since the last revision or reapproval.

This standard has been approved for use by agencies of the Department of Defense.

1. Scope

1.1 This test method determines the transverse tensile properties of wound polymer matrix composites reinforced by high-modulus continuous fibers. It describes testing of hoop wound (90°) cylinders in axial tension for determination of transverse tensile properties.

1.2 The technical content of this standard has been stable since 1993 without significant objection from its stakeholders. As there is limited technical support for the maintenance of this standard, changes since that date have been limited to items required to retain consistency with other ASTM D30 Committee standards, including editorial changes and incorporation of updated guidance on specimen preconditioning and environmental testing. The standard, therefore, should not be considered to include any significant changes in approach and practice since 1993. Future maintenance of the standard will only be in response to specific requests and performed only as technical support allows.

1.3 The values stated in either SI units or inch-pound units are to be regarded separately as standard. The values stated in each system are not exact equivalents; therefore, each system must be used independently of the other. Combining values from the two systems may result in nonconformance with the standard.

1.3.1 Within the text, the inch-pound units are shown in brackets.

1.4 *This standard does not purport to address all of the safety concerns, if any, associated with its use. It is the responsibility of the user of this standard to establish appropriate safety and health practices and determine the applicability of regulatory limitations prior to use.*

2. Referenced Documents

2.1 *ASTM Standards:*²

D792 [Test Methods for Density and Specific Gravity \(Relative Density\) of Plastics by Displacement](#)

D883 [Terminology Relating to Plastics](#)

D2584 [Test Method for Ignition Loss of Cured Reinforced Resins](#)

D2734 [Test Methods for Void Content of Reinforced Plastics](#)

D3171 [Test Methods for Constituent Content of Composite Materials](#)

D3878 [Terminology for Composite Materials](#)

D5229/D5229M [Test Method for Moisture Absorption Properties and Equilibrium Conditioning of Polymer Matrix Composite Materials](#)

D5448/D5448M [Test Method for Inplane Shear Properties of Hoop Wound Polymer Matrix Composite Cylinders](#)

D5449/D5449M [Test Method for Transverse Compressive Properties of Hoop Wound Polymer Matrix Composite Cylinders](#)

E4 [Practices for Force Verification of Testing Machines](#)

E6 [Terminology Relating to Methods of Mechanical Testing](#)

E111 [Test Method for Young's Modulus, Tangent Modulus, and Chord Modulus](#)

E122 [Practice for Calculating Sample Size to Estimate, With Specified Precision, the Average for a Characteristic of a Lot or Process](#)

¹ This test method is under the jurisdiction of ASTM Committee D30 on Composite Materials and is the direct responsibility of Subcommittee D30.04 on Lamina and Laminate Test Methods.

Current edition approved Nov. 15, 2011. Published December 2011. Originally approved in 1993. Last previous edition approved in 2006 as D5450/D5450M-93 (2006). DOI: 10.1520/D5450_D5450M-11.

Current edition approved April 1, 2012. Published May 2012. Originally approved in 1993. Last previous edition approved in 2011 as D5450/D5450M-11. DOI: 10.1520/D5450_D5450M-12.

² For referenced ASTM standards, visit the ASTM website, www.astm.org, or contact ASTM Customer Service at service@astm.org. For *Annual Book of ASTM Standards* volume information, refer to the standard's Document Summary page on the ASTM website.

- E132 Test Method for Poisson's Ratio at Room Temperature
- E177 Practice for Use of the Terms Precision and Bias in ASTM Test Methods
- E251 Test Methods for Performance Characteristics of Metallic Bonded Resistance Strain Gauges
- E456 Terminology Relating to Quality and Statistics
- E691 Practice for Conducting an Interlaboratory Study to Determine the Precision of a Test Method
- E1012 Practice for Verification of Test Frame and Specimen Alignment Under Tensile and Compressive Axial Force Application
- E1237 Guide for Installing Bonded Resistance Strain Gages

3. Terminology

3.1 *Definitions*—Terminology D3878 defines terms relating to high-modulus fibers and their composites. Terminology D883 defines terms relating to plastics. Terminology E6 defines terms relating to mechanical testing. Terminology E456 and Practice E177 define terms relating to statistics. In the event of a conflict between terms, Terminology D3878 shall have precedence over other standards.

NOTE 1—If the term represents a physical quantity, its analytical dimensions are stated immediately following the term (or letter symbol) in fundamental dimension form, using the following ASTM standard symbology for fundamental dimensions, shown within square brackets: [M] for mass, [L] for length, [T] for time, [θ] for thermodynamic temperature, and [nd] for non-dimensional quantities. Use of these symbols is restricted to analytical dimensions when used with square brackets, as the symbols may have other definitions when used without the brackets.

3.2 Descriptions of Terms:

- 3.2.1 *hoop wound, n*—a winding of a cylindrical component where the filaments are circumferentially oriented.
- 3.2.2 *specimen, n*—a single part cut from a winding. Each winding may yield several specimens.
- 3.2.3 *transverse tensile elastic modulus, E_{22} [ML⁻¹T⁻²], n*—the tensile elastic modulus of a unidirectional material in the direction perpendicular to the reinforcing fibers.
- 3.2.4 *transverse tensile strain at failure, ϵ_{22}^{ut} [nd], ut [nd], n*—the value of strain, perpendicular to the reinforcing fibers in a unidirectional material, at failure when a tensile force is applied in the direction perpendicular to the reinforcing fibers.
- 3.2.5 *transverse tensile strength, σ_{22}^{ut} [ML⁻¹T⁻²], ut [ML⁻¹T⁻²], n*—the strength of a unidirectional material when a tensile force is applied in the direction perpendicular to the reinforcing fibers.
- 3.2.6 *winding, n*—an entire part completed by one winding operation and then cured.

4. Summary of Test Method

4.1 A thin walled hoop wound cylinder nominally 100 mm [4 in.] in diameter and 140 mm [5.5 in.] in length is bonded into two end fixtures. The specimen/fixture assembly is mounted in the testing machine and monotonically loaded in tension while recording force. The transverse tensile strength can be determined from the maximum force carried prior to failure. If the cylinder strain is monitored with strain gages, then the stress-strain response of the material can be determined. From the stress-strain response the transverse tensile strain at failure, transverse tensile modulus of elasticity, and Poisson's ratio can be derived.

5. Significance and Use

5.1 This test method is used to produce transverse tensile property data for material specifications, research and development, quality assurance, and structural design and analysis. Factors which influence the transverse tensile response and should, therefore, be reported are: material, methods of material preparation, specimen preparation, specimen conditioning, environment of testing, specimen alignment and gripping, speed of testing, void content, and fiber volume fraction. Properties, in the test direction, which may be obtained from this test method include:

- 5.1.1 *Transverse Tensile Strength, σ_{22}^{ut} ,*
- 5.1.2 *Transverse Tensile Strain at Failure, ϵ_{22}^{ut} ,*
- 5.1.3 *Transverse Tensile Modulus of Elasticity, E_{22} , and*
- 5.1.4 *Poisson's Ratio, ν_{21} .*

6. Interference

6.1 *Material and Specimen Preparation*—Poor material fabrication practices, lack of control of fiber alignment, and damage induced by improper specimen machining are known causes of high material data scatter in composites.

6.2 *Bonding Specimens to Test Fixtures*—A high percentage of failures in or near the bond between the test specimen and the test fixtures, especially when combined with high material data scatter, is an indicator of specimen bonding problems. Specimen to fixture bonding is discussed in 11.5.

6.3 *System Alignment*—Excessive bending may cause premature failure, as well as highly inaccurate modulus of elasticity determination. Every effort should be made to eliminate excess bending from the test system. Bending may occur due to misaligned grips, misaligned specimens in the test fixtures, or from departures of the specimen from tolerance requirements. The alignment should always be checked as discussed in 13.2.

7. Apparatus

- 7.1 *Micrometers*, suitable ball type for reading to within 0.025 ± 0.010 mm [0.001 ± 0.0004 in.] of the specimen inner and

outer diameters. Flat anvil type micrometer or calipers of similar resolution may be used for the overall specimen length and the gage length (the free length between the fixtures).

7.2 *Tension Fixture*—The tension fixture consists of a steel outer shell, insert, load rod, and spherical washer. An assembly drawing for these components and the test fixture is seen in Fig. 1.

7.2.1 *Outer Shell*—The outer shell (metric units Fig. 2, english units Fig. 3) is circular with a concentric circular hollow in one face, a groove along the diameter of the other face, and a center hole through the thickness. Along the diameter perpendicular to the groove, three pairs of small eccentric holes are placed at three radial distances. The two outer pairs of holes are threaded. Four additional threaded holes are placed at the same radial distance as the innermost pair of holes, at ninety degree intervals starting forty-five degrees from the diameter that passes through the center groove.

7.2.2 *Insert*—The fixture insert is circular with a center hole through the thickness (metric units Fig. 4, english units Fig. 5). Two sets of holes are placed along a concentric centerline. These holes align with the innermost set of holes in the outer shell. The set of four holes at ninety degree intervals are counterbored. The insert is fastened inside the hollow of the outer shell to form the concentric groove used to put the specimen in the fixture (Fig. 1).

7.2.3 *Load Rod and Spherical Washers*—Two spherical washers for self alignment are placed over a 0.750-UNC-2A × 6.0 inch load rod. The load rod is then slid through the center hole of the outer shell and insert assembly as illustrated in Fig. 1.

7.2.4 The outer shell and insert for the tension fixture are the same outer shell and insert used for the fixtures in Test Methods D5448/D5448M and D5449/D5449M.

7.3 *Testing Machine*, comprised of the following:

7.3.1 *Fixed Member*—A fixed or essentially stationary member to which one end of the tension specimen/fixture assembly, shown in Fig. 1, can be attached.

7.3.2 *Movable Member*—A movable member to which the opposite end of the tension specimen/fixture assembly, shown in Fig. 1, can be attached.

7.3.3 *Drive Mechanism*, for imparting to the movable member a uniform controlled velocity with respect to the fixed member, this velocity to be regulated as specified in 11.6.

7.3.4 *Force Indicator*—A suitable force-indicating mechanism capable of showing the total tensile force carried by the test specimen. This mechanism shall be essentially free of inertia-lag at the specified rate of testing and shall indicate the force within an accuracy of ± 1 % of the actual value, or better. The accuracy of the testing machine shall be verified in accordance with Practice E4.

7.3.5 *Construction Materials*—The fixed member, movable member, drive mechanism, and fixtures shall be constructed of such materials and in such proportions that the total longitudinal deformation of the system contributed by these parts is minimized.

7.4 *Strain-Indicating Device*—Force versus strain data shall be determined by means of bonded resistance strain gages. Each strain gage shall be 6.3 mm [0.25 in.] in length. The specimen shall be instrumented to measure strain in both the axial and circumferential directions to determine Poisson's ratio. Strain gage rosettes (0°/45°/90°) shall be used to correct for gage misalignment. Gage calibration certification shall comply with Test Method E251. Some guidelines on the use of strain gages on composites are as follows. A general reference on the subject is Tuttle and Brinson.³

7.4.1 *Surface Preparation*—The surface preparation of fiber-reinforced composites, discussed in Practice E1237, can penetrate the matrix material and cause damage to the reinforcing fibers, resulting in improper specimen failures. Reinforcing fibers should not be exposed or damaged during the surface preparation process. The strain gage manufacturer should be consulted regarding

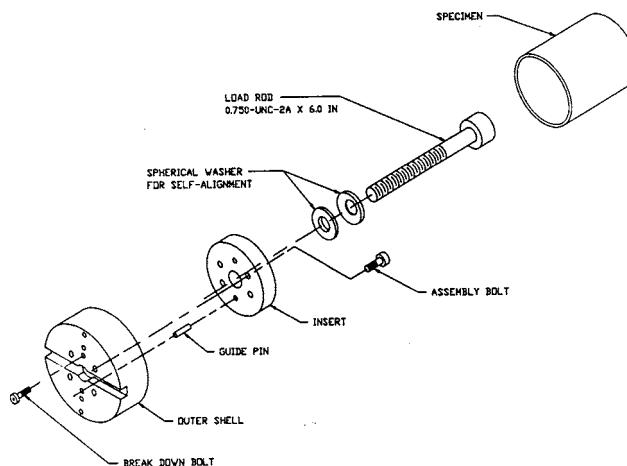

FIG. 1 Assembly Drawing for Tension Fixture and Specimen

³ Tuttle, M. E., and Brinson, H. F., "Resistance-Foil Strain-Gage Technology as Applied to Composite Materials," *Experimental Mechanics*, Vol 24, No. 1, March 1984; pp. 54-64; errata noted in Vol 26, No. 2, Jan. 1986, pp. 153-154.

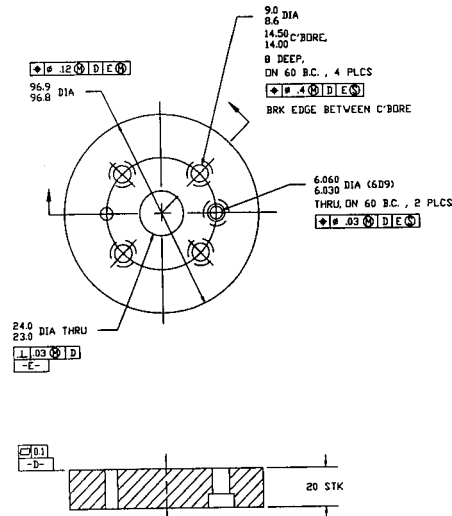

FIG. 4 The Insert of the Tensile Fixture in Metric Units

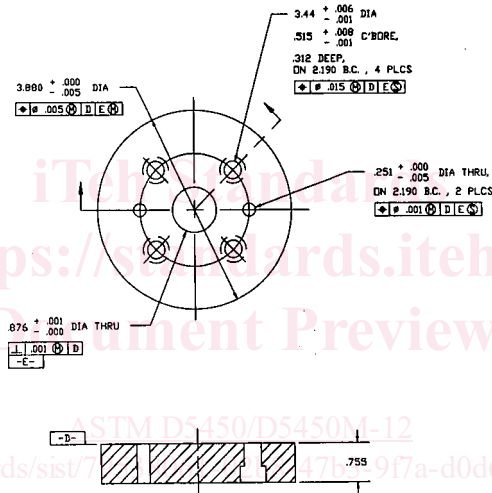

FIG. 5 The Insert of the Tensile Fixture in English Units

7.6 *Environmental Test Chamber*—An environmental test chamber is required for test environment other than ambient testing laboratory conditions. This chamber shall be capable of maintaining the gage section of the test specimen at the required test environment during the mechanical test.

8. Sampling and Test Specimens

8.1 *Sampling*—At least five specimens per test condition should be tested unless valid results can be gained through the use of fewer specimens, such as in the case of a designed experiment. For statistically significant data, the procedures outlined in Practice E122 should be consulted. The method of sampling shall be reported.

NOTE 2—If specimens are to undergo environmental conditioning to equilibrium, and are of such type or geometry that the weight change of the material cannot be properly measured by weighing the specimen itself, then another traveler of the same nominal thickness and appropriate size shall be used to determine when equilibrium has been reached for the specimens being conditioned.

8.2 *Geometry*—The test specimen shall be as shown in Fig. 6. The length of all specimens shall be 140 mm [5.5 in.]. This provides a gage length of 102 mm [4.0 in.]. The inner diameter of all specimens shall be 102 ± 4 mm [4.000 ± 0.015 in.]. Specimens may be fabricated on a tapered mandrel yielding a maximum taper over the specimen length of 0.0005 mm/mm [in./in.] on the diameter. The specimens shall have a nominal wall thickness of 2 mm [0.08 in.], the actual thickness to be specified by the winding parameters and shall be maintained as the test specimen is wound and cured.

8.3 *Winding*—All specimens shall be hoop wound (approximately 90°) with a single tow and enough layers to meet the thickness criterion previously described.

9. Calibration

9.1 The accuracy of all measuring equipment shall have certified calibrations that are current at the time the equipment is used.

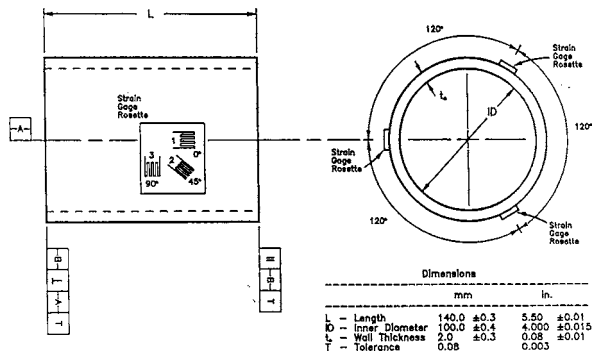

NOTE 1—Tube may be fabricated on a tapered mandrel with maximum taper of 0.0005 in./in. (0.0005 mm/mm) on the diameter.

NOTE 2—Actual measure of inner diameter will depend on specimen placement along tapered mandrel during fabrication.

FIG. 6 Test Specimen Shown with Strain Gage Configuration

10. Conditioning

10.1 The recommended pre-test condition is effective moisture equilibrium at a specific relative humidity as established by Test Method D5229/D5229M; however, if the test requestor does not explicitly specify a pre-test conditioning environment, no conditioning is required and the test specimens may be tested as prepared.

10.2 The pre-test specimen conditioning process, to include specified environmental exposure levels and resulting moisture content, shall be reported with the test data.

NOTE 3—The term moisture, as used in Test Method D5229/D5229M, includes not only the vapor of a liquid and its condensate, but the liquid itself in large quantities, as for immersion.

10.3 If no explicit conditioning process is performed, the specimen conditioning process shall be reported as “unconditioned” and the moisture content as “unknown.”

11. Procedure

11.1 Parameters to be Specified Prior to Test:

11.1.1 The sampling method, specimen geometry, and test parameters used to determine density and reinforcement volume,

11.1.2 The tension specimen sampling method,

11.1.3 The environmental conditioning test parameters, and

11.1.4 The tensile property and data reporting format desired.

NOTE 4—Specific material property, accuracy, and data reporting requirements should be determined prior to test for proper selection of instrumentation and data recording equipment. Estimates of operating stress and strain levels should also be made to aid in transducer selection, calibration of equipment, and determination of equipment settings.

11.2 General Instructions:

11.2.1 Any deviation from this test method shall be reported.

11.2.2 Unless otherwise directed, determine specific gravity and reinforcement and void volume percentages for each winding. Extract the material used for the determination of these properties from the center of the winding if multiple specimens are extracted from one winding or from one of the ends of the winding if only one specimen is extracted from the winding. Determine and report specific gravity and density as specified in Test Method D792. Determine and report volume percent of the constituents by one of the matrix digestion procedures of Test Method D3171, or, for certain reinforcement materials such as glass and ceramic, by the matrix burn-off technique of Test Method D2584. The void content equations of Test Methods D2734 are applicable to both Test Method D2584 and the matrix digestion procedures.

11.2.3 Following any conditioning, but before the tension testing, measure and report the specimen’s outer diameter (OD), inner diameter (ID), and length. The specimens are measured by first marking two randomly selected locations within the middle two-thirds of the specimen length. At each of the points, average four measurements of the outer diameter on an axis that passes through the point and then repeat the procedure on an axis perpendicular to the initial axis. Repeat the procedure for the inner diameter using the same axes. Subtract the average inner diameter from the average outer diameter and divide the remainder by two. This value will be used as the composite wall thickness, t_c . Also, obtain four length measurements, made at 90° intervals around the specimen circumference, and compute their average. This value will be used as the specimen length.

11.3 *Strain Gage Installation*—Attach strain gages to the center of the specimen’s gage section. Three strain gage rosettes (oriented as 0°/45°/90°, where 0° is parallel to the specimen axis), mounted 120° around the specimen outer circumference from each other as shown in Fig. 6, are recommended in order to ascertain that only tensile loading is being applied. Non-tensile loading