



Designation: ~~D6264/D6264M-07~~ Designation: D6264/D6264M – 12

Standard Test Method for Measuring the Damage Resistance of a Fiber-Reinforced Polymer-Matrix Composite to a Concentrated Quasi-Static Indentation Force¹

This standard is issued under the fixed designation D6264/D6264M; the number immediately following the designation indicates the year of original adoption or, in the case of revision, the year of last revision. A number in parentheses indicates the year of last reapproval. A superscript epsilon (ϵ) indicates an editorial change since the last revision or reapproval.

1. Scope

1.1 This test method determines the damage resistance of multidirectional polymer matrix composite laminated plates subjected to a concentrated indentation force (Fig. 1). Procedures are specified for determining the damage resistance for a test specimen supported over a circular opening and for a rigidly-backed test specimen. The composite material forms are limited to continuous-fiber reinforced polymer matrix composites, with the range of acceptable test laminates and thicknesses defined in 8.2. This test method may prove useful for other types and classes of composite materials.

1.1.1 Instructions for modifying these procedures to determine damage resistance properties of sandwich constructions are provided in Practice D7766/D7766M.

1.2 A flat, square composite plate is subjected to an out-of-plane, concentrated force by slowly pressing a hemispherical indenter into the surface. The damage resistance is quantified in terms of a critical contact force to cause a specific size and type of damage in the specimen.

1.3 The test method may be used to screen materials for damage resistance, or to inflict damage into a specimen for subsequent damage tolerance testing. The indented plate can be subsequently tested in accordance with Test Method D7137/D7137M to measure residual strength properties. Drop-weight impact per Test Method D7136/D7136M may be used as an alternate method of creating damage from an out-of-plane force and measuring damage resistance properties.

1.4 The damage resistance properties generated by this test method are highly dependent upon several factors, which include specimen geometry, layup, indenter geometry, force, and boundary conditions. Thus, results are generally not scalable to other configurations, and are particular to the combination of geometric and physical conditions tested.

1.5 The values stated in either SI units or inch-pound units are to be regarded separately as standard. ~~Within the text the inch-pound units are shown in brackets.~~ The values stated in each system ~~are~~ may not be exact equivalents; therefore, each system ~~must~~ shall be used independently of the other. Combining values from the two systems may result in non-conformance with the standard.

1.5.1 Within the text the inch-pound units are shown in brackets. https://doi.org/10.1520/D6264_D6264M-12

1.6 *This standard does not purport to address all of the safety concerns, if any, associated with its use. It is the responsibility of the user of this standard to establish appropriate safety and health practices and determine the applicability of regulatory limitations prior to use.*

2. Referenced Documents

2.1 *ASTM Standards:*²

D792 [Test Methods for Density and Specific Gravity \(Relative Density\) of Plastics by Displacement](#)

D883 [Terminology Relating to Plastics](#)

D3171 [Test Methods for Constituent Content of Composite Materials](#)

D3878 [Terminology for Composite Materials](#)

D5229/D5229M [Test Method for Moisture Absorption Properties and Equilibrium Conditioning of Polymer Matrix Composite Materials](#)

D5687/D5687M [Guide for Preparation of Flat Composite Panels with Processing Guidelines for Specimen Preparation](#)

¹ This ~~standard test method~~ is under the jurisdiction of ASTM Committee D30 on Composite Materials and is the direct responsibility of Subcommittee D30.05 on Structural Test Methods.

Current edition approved ~~Nov. April 1, 2007-2012~~. Published ~~December 2007-May 2012~~. Originally approved in 1998. Last previous edition approved in ~~2004~~ 2007 as ~~D6264-98(2004)-D6264-07~~. DOI: 10.1520/D6264_D6264M-07.12.

² For referenced ASTM standards, visit the ASTM website, www.astm.org, or contact ASTM Customer Service at service@astm.org. For *Annual Book of ASTM Standards* volume information, refer to the standard's Document Summary page on the ASTM website.

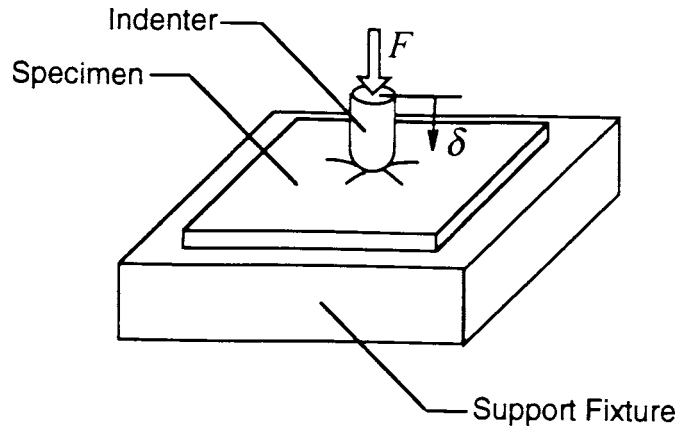

FIG. 1 Quasi-Static Indentation Test

[D7136/D7136M Test Method for Measuring the Damage Resistance of a Fiber-Reinforced Polymer Matrix Composite to a Drop-Weight Impact Event](#)

[D7137/D7137M Test Method for Compressive Residual Strength Properties of Damaged Polymer Matrix Composite Plates](#)

[D7766/D7766M Practice for Damage Resistance Testing of Sandwich Constructions](#)

[E4 Practices for Force Verification of Testing Machines](#)

[E6 Terminology Relating to Methods of Mechanical Testing](#)

[E18 Test Methods for Rockwell Hardness of Metallic Materials](#)

[E122 Practice for Calculating Sample Size to Estimate, With Specified Precision, the Average for a Characteristic of a Lot or Process](#)

[E177 Practice for Use of the Terms Precision and Bias in ASTM Test Methods](#)

[E456 Terminology Relating to Quality and Statistics](#)

[E1309 Guide for Identification of Fiber-Reinforced Polymer-Matrix Composite Materials in Databases](#)

[E1434 Guide for Recording Mechanical Test Data of Fiber-Reinforced Composite Materials in Databases](#)

[E1471 Guide for Identification of Fibers, Fillers, and Core Materials in Computerized Material Property Databases](#) [Guide for Identification of Fibers, Fillers, and Core Materials in Computerized Material Property Databases](#)

[E2533 Guide for Nondestructive Testing of Polymer Matrix Composites Used in Aerospace Applications](#)

2.2 Military Standards:

[MIL-HDBK-17-3F Composite Materials Handbook, Volume 3—Polymer Matrix Composites Materials Usage, Design and Analysis](#)³

[MIL-HDBK-728/1 Nondestructive Testing](#)⁴

[MIL-HDBK-731A Nondestructive Testing Methods of Composite Materials—Thermography](#)⁴

[MIL-HDBK-732A Nondestructive Testing Methods of Composite Materials—Acoustic Emission](#)⁴

[MIL-HDBK-733A Nondestructive Testing Methods of Composite Materials—Radiography](#)⁴

[MIL-HDBK-787A Nondestructive Testing Methods of Composite Materials—Ultrasonics](#)⁴

3. Terminology

3.1 *Definitions*—Terminology D3878 defines terms relating to composite materials. Terminology D883 defines terms relating to plastics. Terminology E6 defines terms relating to mechanical testing. Terminology E456 and Practice E177 define terms relating to statistics. In the event of a conflict between terms, Terminology D3878 shall have precedence over the other standards.

3.2 Definitions of Terms Specific to This Standard:

3.2.1 If the term represents a physical quantity, its analytical dimensions are stated immediately following the term (or letter symbol) in fundamental dimension form, using the following ASTM standard symbology for fundamental dimensions, shown within square brackets: $[M]$ for mass, $[L]$ for length, $[T]$ for time, $[\theta]$ for thermodynamic temperature, and $[nd]$ for non-dimensional quantities. Use of these symbols is restricted to analytical dimensions when used with square brackets, as the symbols may have other definitions when used without the brackets.

3.2.2 *contact force, F $[MLT^{-2}]$, n* —the force exerted by the indenter on the specimen during the test, as recorded by a force indicator.

3.2.3 *dent depth, d $[L]$, n* —residual depth of the depression formed by an indenter after removal of applied force. The dent depth shall be defined as the maximum distance in a direction normal to the face of the specimen from the lowest point in the dent to the plane of the surface that is undisturbed by the dent.

³ Available from U.S. Army Research Laboratory, Materials Directorate, Aberdeen Proving Ground, MD 21001.

⁴ Available from U.S. Army Materials Technology Laboratory, Watertown, MA 02471.

3.2.4 *indenter displacement*, δ [L], n —the displacement of the indenter relative to the specimen support.

3.2.5 *nominal value*, n —a value, existing in name only, assigned to a measurable property for the purpose of convenient designation. Tolerances may be applied to a nominal value to define an acceptable range for the property.

3.2.6 *principal material coordinate system*, n —a coordinate system with axes that are normal to the planes of symmetry inherent to a material.

3.2.6.1 *Discussion*—Common usage, at least for Cartesian axes (123, xyz , and so forth), generally assigns the coordinate system axes to the normal directions of planes of symmetry in order that the highest property value in a normal direction (for elastic properties, the axis of greatest stiffness) would be 1 or x , and the lowest (if applicable) would be 3 or z . Anisotropic materials do not have a principal material coordinate system due to the total lack of symmetry, while, for isotropic materials, any coordinate system is a principal material coordinate system. In laminated composites, the principal material coordinate system has meaning only with respect to an individual orthotropic lamina. The related term for laminated composites is *reference coordinate system*.

3.2.7 *reference coordinate system*, n —a coordinate system for laminated composites used to define ply orientations. One of the reference coordinate system axes (normally the Cartesian x -axis) is designated the reference axis, assigned a position, and the ply principal axis of each ply in the laminate is referenced relative to the reference axis to define the ply orientation for that ply.

3.3 Symbols:

CV = coefficient of variation statistic of a sample population for a given property (in percent)

D = damage diameter (see Fig. 6)

d = dent depth (see 3.2.3)

E = energy calculated by integrating the contact force and indenter displacement curve

E_a = energy absorbed (inelastically) by the specimen during the test

E_{max} = energy at maximum indenter displacement

F = contact force (see 3.2.2)

F_{max} = the maximum contact force exerted on the specimen during a test

n = number of specimens per sample population

N = number of plies in laminate under test

s_{n-1} = standard deviation statistic of a sample population for a given property

x_i = test result for an individual specimen from the sample population for a given property

\bar{x} = mean or average (estimate of mean) of a sample population for a given property

δ = indenter displacement (see 3.2.4)

δ_o = indenter displacement at initial specimen contact

δ_f = indenter displacement at the end of the unloading cycle

δ_{max} = maximum indenter displacement during the test

4. Summary of Test Method

4.1 A quasi-static indentation (QSI) test is used to measure the damage resistance on a balanced, symmetric laminated plate. Damage is imparted through an out-of-plane, concentrated force (perpendicular to the plane of the laminated plate) applied by slowly pressing a displacement-controlled hemispherical indenter into the face of the specimen (Fig. 1). The damage resistance is quantified in terms of the resulting size and type of damage in the specimen. The damage response is a function of the test configuration; comparisons cannot be made between materials unless identical test configurations, test conditions, etc. are used.

4.2 Procedures are specified for determining the damage resistance for a test specimen supported over a circular opening (edge supported) and for a rigidly-backed test specimen.

4.3 Preferred damage states are centered on the plate and are away from the plate edges.

5. Significance and Use

5.1 Susceptibility to damage from concentrated out-of-plane forces is one of the major design concerns of many structures made of advanced composite laminates. Knowledge of the damage resistance properties of a laminated composite plate is useful for product development and material selection.

5.2 QSI testing can serve the following purposes:

5.2.1 To simulate the force-displacement relationships of impacts governed by boundary conditions **(1-7)**.⁵ These are typically relatively large-mass low-velocity hard-body impacts on plates with a relatively small unsupported region. Since the test is run slowly in displacement control, the desired damage state can be obtained in a controlled manner. Associating specific damage events with a force during a drop-weight impact test is often difficult due to the oscillations in the force history. In addition, a specific sequence of damage events may be identified during quasi-static loading while the final damage state is only identifiable after a drop-weight impact test.

5.2.2 To provide an estimate of the impact energy required to obtain a similar damage state for drop-weight impact testing if all others parameters are held constant.

⁵ The boldface numbers in parentheses refer to the list of references at the end of this standard.

5.2.3 To establish quantitatively the effects of stacking sequence, fiber surface treatment, variations in fiber volume fraction, and processing and environmental variables on the damage resistance of a particular composite laminate to a concentrated indentation force.

5.2.4 To compare quantitatively the relative values of the damage resistance parameters for composite materials with different constituents. The damage response parameters can include dent depth, damage dimensions and through-thickness locations, F_{max} , E_a , and E_{max} , as well as the force versus indenter displacement curve.

5.2.5 To impart damage in a specimen for subsequent damage tolerance tests, such as Test Method D7137/D7137M.

5.2.6 To measure the indentation response of the specimen with and without bending using the two specimen configurations (edge supported and rigidly backed).

5.3 The properties obtained using this test method can provide guidance in regard to the anticipated damage resistance capability of composite structures of similar material, thickness, stacking sequence, etc. However, it must be understood that the damage resistance of a composite structure is highly dependent upon several factors including geometry, thickness, stiffness, mass, support conditions, etc. Significant differences in the relationships between force/energy and the resultant damage state can result due to differences in these parameters. For example, properties obtained using the specimen supported over a circular hole would more likely reflect the damage resistance characteristics of an un-stiffened monolithic skin or web than that of a skin attached to sub-structure which resists out-of-plane deformation. Similarly, test specimen properties would be expected to be similar to those of a panel with equivalent length and width dimensions, in comparison to those of a panel significantly larger than the test specimen, which tends to divert a greater proportion of the energy into elastic deformation.

~~5.4 The standard indenter geometry has a blunt, hemispherical tip. Historically, for the standard laminate configuration, this indenter geometry has generated a larger amount of internal damage for a given amount of external damage than is typically observed for similar indenters using sharp tips.~~

5.4 The standard indenter geometry has a blunt, hemispherical tip. Historically, for the standard laminate configuration, this indenter geometry has generated a larger amount of internal damage for a given amount of external damage than is typically observed for similar indenters using sharp tips. Alternative indenter geometries may be appropriate depending upon the damage resistance characteristics being examined. For example, the use of sharp tip geometries may be appropriate for certain damage visibility and penetration resistance assessments.

5.5 Some testing organizations may desire to use this test method in conjunction with Test Method D7137/D7137M to assess the compression residual strength of specimens containing a specific damage state, such as a defined dent depth, damage geometry, etc. In this case, the testing organization should subject several specimens to multiple energy or force levels using this test method. A relationship between energy or force and the desired damage parameter can then be developed. Subsequent QSI and compression residual strength tests can then be performed using specimens indented at an interpolated energy or force level that is expected to produce the desired damage state.

6. Interferences

6.1 This test may be useful in simulating the force-displacement relationships of large-mass low-velocity hard-body impacts on small plates. However, this test method does not address wave propagation and vibrations in the specimen, time-dependent material behavior, or inertia-dominated impact events.

6.2 The response of a laminated plate specimen to an out-of-plane force is dependent upon many factors, such as laminate thickness, ply thickness, stacking sequence, environment, geometry, indenter tip geometry, and boundary conditions. Consequently, comparisons cannot be made between materials unless identical test configurations, test conditions, and laminate configurations are used. Therefore, all deviations from the standard test configuration shall be reported in the results.

6.3 *Material and Specimen Preparation*—Poor material fabrication practices, lack of control of fiber alignment, and damage induced by improper specimen machining are known causes of high material data scatter in composites in general. Important aspects of plate specimen preparation that contribute to data scatter include thickness variation, out-of-plane curvature, surface roughness, and failure to maintain the dimensions specified in 8.2.

6.4 *Specimen Geometry and Indentation Location*—The size, shape, thickness, and stacking sequence of the plate, along with the indentation location, can affect the specimen deformation and damage formation behavior of the specimens significantly. The degree of laminate orthotropy can strongly affect the damage formation. Results can be affected if the indentation force is not applied perpendicular to the plane of the laminated plate.

6.5 *Support Fixture Characteristics*—Results are affected by the support fixture geometry, material, and bending rigidity.

6.6 *Non-Destructive Inspection*—Non-destructive inspection (NDI) results are affected by the particular method utilized, the inherent variability of the NDI method, the experience of the operator, etc.

6.7 The dent depth may “relax” or reduce with time or upon exposure to different environmental conditions.

6.8 Non-laminated, 3-D fiber-reinforced composites may form damage through different mechanisms than laminates.

7. Apparatus

7.1 *Micrometers and Calipers*—The accuracy of the instruments shall be suitable for reading to within 0.1 % of the measured value. The micrometer(s) shall use a 4 to 6 mm [0.16 to 0.25 in.] nominal diameter ball interface on irregular surfaces such as the bag side of a laminate, and a flat anvil interface on machined edges or very smooth tooled surfaces.

NOTE 1—For typical specimen geometries, a micrometer with an accuracy of ± 0.0025 mm [± 0.0001 in.] or better is desirable for thickness measurement, while a caliper with an accuracy of ± 0.025 mm [± 0.001 in.] or better is desirable for length, width and damage dimension measurement.

7.2 *Support Fixtures*—The damage resistance may be determined for a specimen that is edge supported or rigidly backed. For both configurations, the specimen’s face shall be held normal to the axis of the indenter.

7.2.1 *Edge Supported Configuration*—The fixture shall consist of a single plate with a 125.0 ± 3.0 mm [5.00 ± 0.10 in.] diameter opening made from a structural metal such as aluminum or steel. The face of the plate shall be flat to within 0.1 mm [0.005 in.] in the area which contacts the test specimen. The top rim of the opening shall be rounded with a radius of 0.75 ± 0.25 mm [0.03 ± 0.01 in.]. The plate shall be sufficiently large to support the entire lower surface of the specimen, excluding the circular opening. The thickness of the plate shall be a minimum of 25 mm [1.0 in.] and greater than the expected maximum indenter displacement. A typical support fixture is shown in Figs. 2 and 3.

7.2.2 *Rigidly-Backed Configuration*—The specimen shall be placed directly on the flat rigid support that is mounted in the lower head of the testing machine. For this configuration, the support shall be made from steel with a minimum thickness of 12.7 mm [0.5 in.].

7.3 *Testing Machine*—The testing machine shall be in conformance with Practices E4 and shall satisfy the following requirements:

7.3.1 *Testing Machine Configuration*—The testing machine shall have both an essentially stationary head and a movable head. A short loading train shall be used with a flat platen on the lower head and a grip on the upper head.

7.3.2 *Grips*—The top head of the testing machine shall carry a grip to hold the indenter such that the direction of load applied to the specimen is coincident with the axis of travel. The grip shall apply sufficient pressure to prevent slippage of the indenter. The lower head shall have a means of attaching a flat platen.

7.3.3 *Flat Platen*—The test machine shall be mounted with a fixed (as opposed to spherical seat) flat platen on the lower head to support the specimen or test fixture. The support surface shall be normal to the axis of travel of the testing machine head and have a large enough surface to support completely the specimen or test fixture. A convenient means of providing this surface is through the use of a metal “T” in which the lower part of the “T” is clamped in the lower grips and the top part of the “T” provides the support surface. The lower platen may be marked to help center the test fixture between the platens. If the rigidly-backed configuration is to be used, this support shall be made from steel with a minimum thickness of 13 mm [0.5 in.].

7.3.4 *Drive Mechanism*—The testing machine drive mechanism shall be capable of imparting to the movable head a controlled velocity with respect to the stationary head. The velocity of the movable head shall be capable of being regulated as specified in 11.6.

7.3.5 *Force Indicator*—The testing machine force-sensing device shall be capable of indicating the total force being carried by the test specimen. This device shall be essentially free from inertia-lag at the specified rate of testing and shall indicate the force with accuracy over the force range(s) of interest of within ± 1 % of the indicated value.

7.3.6 *Crosshead Displacement Indicator*—The testing machine shall be capable of monitoring and recording the crosshead displacement (stroke) with a precision of at least ± 1 %. If machine and fixture compliance is significant, it is acceptable to measure the displacement of the movable head using a LVDT or similar device with ± 1 % precision on displacement.

7.4 *Indenter*—The indenter shall have a smooth hemispherical tip with a diameter of 13.0 ± 0.3 mm [0.50 ± 0.01 in.] and a hardness of 60 to 62 HRC as specified in Test Methods E18. If a different indenter is used as part of the testing, the shape and

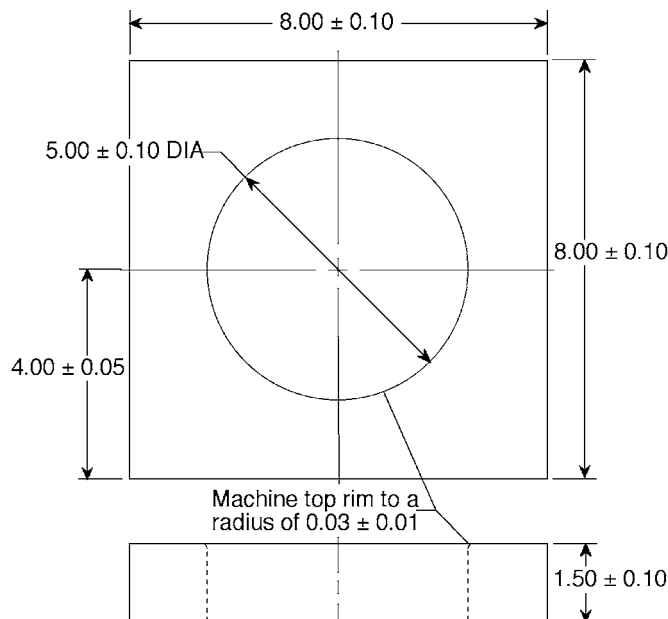

FIG. 2 Typical Fixture with Open Hole (Inch-Pound Version)

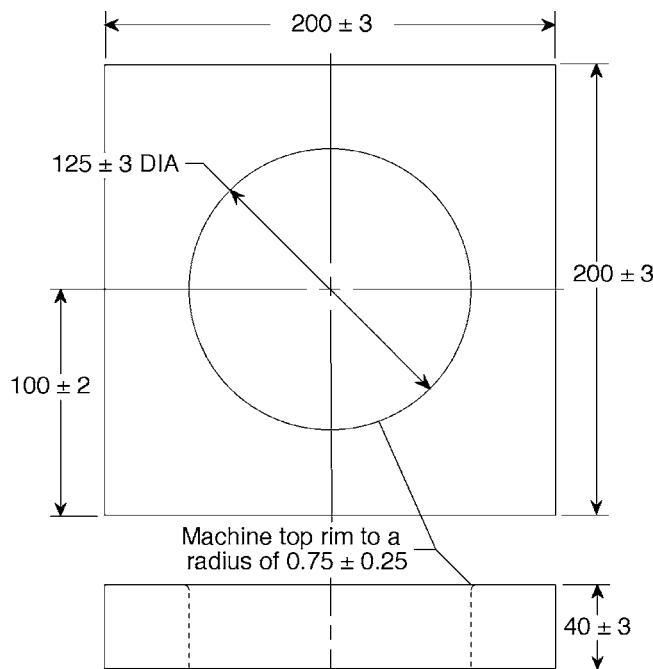

FIG. 3 Typical Fixture with Open Hole (SI Version)

dimensions shall be noted. Alternate tip geometries may be used to study relationships between visible damage geometry (e.g., dent depth, dent diameter) and the internal damage state. If a different indenter is used as part of the testing, the shape and dimensions shall be noted.

7.5 *Conditioning Chamber*—When conditioning materials at non-laboratory environments, a temperature-/vapor-level controlled environmental conditioning chamber is required that shall be capable of maintaining the required temperature to within $\pm 3^{\circ}\text{C}$ [$\pm 5^{\circ}\text{F}$] and the required relative humidity level to within $\pm 3\%$. Chamber conditions shall be monitored either on an automated continuous basis or on a manual basis at regular intervals.

7.6 *Environmental Test Chamber*—An environmental test chamber is required for test environments other than ambient testing laboratory conditions. This chamber shall be capable of maintaining the test specimen at the required test environment during the mechanical test. The test temperature shall be maintained within $\pm 3^{\circ}\text{C}$ [$\pm 5^{\circ}\text{F}$] of the required temperature, and the relative humidity level shall be maintained to within $\pm 3\%$ of the required humidity level.

7.7 *Data Acquisition Equipment*—Equipment capable of recording force and crosshead displacement is required.

7.8 *Dent Depth Indicator*—The dent depth can be measured using a dial depth gage, a depth gage micrometer, a tripod-mounted depth gage, or a properly calibrated displacement transducer. The measuring probe shall have a spherical tip with a maximum radius of curvature of 8.0 mm [0.35 in.]. An instrument with an accuracy of $\pm 25\ \mu\text{m}$ [$\pm 0.001\ \text{in.}$] is desirable for depth measurement.

8. Sampling and Test Specimens

8.1 *Sampling*—Test at least five specimens per test condition unless valid results can be gained through the use of fewer specimens, as in the case of a designed experiment. For statistically significant data the procedures outlined in Practice E122 should be consulted. The method of sampling shall be reported.

8.2 Geometry:

8.2.1 *Stacking Sequence*—The reference coordinate system shall coincide with the specimen edges. For comparison screening of the damage resistance of different materials, the standard specimen thickness shall be 4.0 to 6.0 mm [0.16 to 0.24 in.] and the laminate defined as follows:

8.2.1.1 *Unidirectional Tape*—Laminate construction shall consist of unidirectional plies with a stacking sequence of $[(+45/0/-45/90)]_N$ where N is a whole number. The recommended layups for various nominal cured ply thicknesses are provided in Table 1.

8.2.1.2 *Woven Fabric*—Laminate construction shall consist of fabric plies with a stacking sequence of $[(+45/-45)/(0/90)]_N$ where N is a whole number. The designations (+45/-45) and (0/90) represent a single layer of woven fabric with the warp and weft fibers oriented at the specified angles. Fabric laminates containing satin-type weaves shall have symmetric warp surfaces, unless otherwise specified and noted in the report. The recommended layups for various nominal cured ply thicknesses are provided in Table 2.

8.2.1.3 *Alternative Stacking Sequences*—Laminates fabricated using other layups or fiber orientations may be evaluated for damage resistance using this test method. Tests conducted using alternative stacking sequences must be designated as such, with