

---

International Standard



3002/3

---

INTERNATIONAL ORGANIZATION FOR STANDARDIZATION • МЕЖДУНАРОДНАЯ ОРГАНИЗАЦИЯ ПО СТАНДАРТИЗАЦИИ • ORGANISATION INTERNATIONALE DE NORMALISATION

---

**Basic quantities in cutting and grinding —  
Part 3 : Geometric and kinematic quantities in cutting**

*Grandeurs de base en usinage et rectification — Partie 3: Grandeurs géométriques et cinématiques en usinage*

First edition — 1984-11-01

**ITeH STANDARD PREVIEW**  
**(standards.iteh.ai)**

[ISO 3002-3:1984](https://standards.iteh.ai/catalog/standards/sist/65a1c0df-3f92-47f1-a396-d79ac1f02546/iso-3002-3-1984)

<https://standards.iteh.ai/catalog/standards/sist/65a1c0df-3f92-47f1-a396-d79ac1f02546/iso-3002-3-1984>



---

UDC 621.91.01

Ref. No. ISO 3002/3-1984 (E)

Descriptors : tools, cutting tools, cutting angle, geometrical characteristics, definitions.

## Foreword

ISO (the International Organization for Standardization) is a worldwide federation of national standards bodies (ISO member bodies). The work of preparing International Standards is normally carried out through ISO technical committees. Every member body interested in a subject for which a technical committee has been established has the right to be represented on that committee. International organizations, governmental and non-governmental, in liaison with ISO, also take part in the work.

Draft International Standards adopted by the technical committees are circulated to the member bodies for approval before their acceptance as International Standards by the ISO Council. They are approved in accordance with ISO procedures requiring at least 75 % approval by the member bodies voting.

International Standard ISO 3002/3 was prepared by Technical Committee ISO/TC 29, *Small tools*.

**ITeH STANDARD PREVIEW**  
(standards.iteh.ai)

ISO 3002-3:1984

<https://standards.iteh.ai/catalog/standards/sist/65a1c0df-3f92-47f1-a396-d79ac1f02546/iso-3002-3-1984>

# Basic quantities in cutting and grinding — Part 3: Geometric and kinematic quantities in cutting

## 0 Introduction

Upon completion of ISO 3002/1 and ISO 3002/2 it was realized that a series of basic concepts related to metal cutting and grinding were explicitly referred to, implied, or considered as self-evident, but had never been properly defined. Preparation of an International Standard on basic concepts in cutting, which would be applicable in the general field of cutting operations, including grinding, was therefore necessary.

The concepts of forces, energy and power are covered in ISO 3002/4, while ISO 3002/5 deals more specifically with grinding.

## 1 Scope and field of application

This International Standard defines a nomenclature for certain basic concepts concerning the machining and grinding of materials. This part of ISO 3002 deals specifically with geometric and kinematic quantities in cutting. It should be read in conjunction with part 1 of this International Standard which is more general.

It is generally applicable to all machining operations, including grinding. For grinding however, several additional geometric and kinematic quantities are defined in ISO 3002/5.

The definitions are divided into six main clauses which deal with feed, cutting edge and related quantities, engagement, the cut and its dimensions, the pass and its dimensions, and the material removal rate respectively.

NOTE — In addition to the terms given in the three official ISO languages (English, French, Russian), this part of ISO 3002 gives the equivalent terms in German, Italian and Dutch; these terms have been included at the request of Technical Committee ISO/TC 29, and are published under the responsibility of the committee members for Germany, F.R. (DIN), Italy (UNI) and the Netherlands (NNI). However, only the terms given in the official languages can be considered as ISO terms.

## 2 References

ISO 3002/1, *Basic quantities in cutting and grinding — Part 1: Geometry of the active part of cutting tools — General terms, reference systems, tool and working angles, chip breakers.*

ISO 3002/2, *Basic quantities in cutting and grinding — Part 2: Geometry of the active part of cutting tools — General conversion formulae to relate tool and working angles.*

ISO 3002/4, *Basic quantities in cutting and grinding — Part 4: Forces, energy, power.*

ISO 3002/5, *Basic quantities in cutting and grinding — Part 5: Basic terminology concerning grinding by wheel.*<sup>1)</sup>

## 3 Kinematic quantities

Definitions of quantities of motion and speed are given in ISO 3002/1 under the following clauses as indicated:

- primary motion, see 3.6.1
- direction of primary motion, see 3.6.1.1
- cutting speed  $v_c$ , see 3.6.1.2
- feed motion, see 3.6.2
- direction of feed motion, see 3.6.2.1
- feed speed  $v_f$ , see 3.6.2.2
- resultant feed motion, see 3.6.3
- resultant cutting speed  $v_e$ , see 3.6.3.2

### NOTES

- 1 Definitions of all concepts mentioned or used in this part of ISO 3002 are printed in *italics*; they can be found either in the body of this part or in part 1, to which the reader is referred.
- 2 All quantities defined in ISO 3002/1 may vary in time: they are defined and should be measured as instantaneous quantities at a certain instant in time, unless clearly specified otherwise. When average values are intended, the period considered shall be indicated.
- 3 In the case of an *interrupted cutting edge*, the individual portions of the *cutting edge* may be considered as separated *cutting parts* or as a whole. The method to be applied should be specified.

## 4 Feed (see figures 1, 2, 3 and 9)

The displacement of the tool relative to the workpiece in the *direction of feed motion*: it may be stated and measured in terms of displacement per stroke or per revolution of the tool or workpiece and then designated by  $f$ , or stated and measured per *cutting part* of a multitoothed cutting tool and then designated by  $f_z$ .

1) At present at the stage of draft.

NOTE — In some cases to be specified, the motions may be related to the machine base, for instance in milling and grinding operations, and in defining the speed ratio.

## 5 Cutting edge and related quantities

**5.1 active cutting edge  $S_a$ :** See ISO 3002/1.

**5.1.1 length of the active cutting edge  $l_{Sa}$ :** The actual length of the *active cutting edge*.

**5.2 cutting edge principal point D** (see figure 9): A particular reference point on the *active major cutting edge* used to establish basic geometric quantities such as the *active cutting edge profile* and the dimension of cut (see 7.2). It is recommended that the cutting edge principal point be located at the position which divides the length of the *active major cutting edge* into two equal parts.

When any other location is chosen, it shall be clearly specified.

**5.3 cut dimension plane  $P_D$ :** A plane passing through the *cutting edge principal point* D and perpendicular to the *direction of primary motion* at this point.

### 5.4 Cutting edge profile

**5.4.1 active cutting edge profile** (see figure 9): The curve formed by the projection of the *active cutting edge* on the *cut dimension plane*  $P_D$ .

As a special application of ISO 3002/1, the profile of the cutting edge is considered in the *cut dimension plane* whenever related to the dimensions of the cut.

NOTE — To be exact, in cases where the *primary motion* is caused by a rotation, each point on the *active cutting edge* should be projected onto the *cut dimension plane*  $P_D$  along a circular path about the axis of rotation.

This can be important when using a tool with a long *active cutting edge* and a large *cutting edge inclination*, for example, in some reaming operations, in slab milling with a large helix angle, in skiving in a lathe and in drilling.

The smaller the distance between the extremities of the *active cutting edge* and the *cut dimension plane*, and the larger the distance between the *active cutting edge* and the axis of rotation, the better the circular projection can be replaced by the simpler perpendicular projection.

**5.4.2 length of the active cutting edge profile  $l_{SaD}$**  (see figure 9): The length of the projection of the *active cutting edge* in the *cut dimension plane*  $P_D$ .

## 6 Engagement

**6.1 engagement of a cutting edge  $a_S$  or  $a^{1)}$ :** is defined and measured as the distance between two planes, both of

which are perpendicular to the chosen measuring direction and respectively pass through two points on the *active cutting edge* so located that the distance between the two planes is a maximum.

The appropriate suffix must be used for indicating the measuring direction.

NOTE — When more than one *cutting edge* is in simultaneous engagement with the workpiece, the *cutting edge* considered should be specified.

**6.1.1 back engagement of the cutting edge  $a_{Sp}$  or  $a_p^{1)}$**  (see figures 1 to 9): The *engagement of the cutting edge* with the workpiece measured perpendicular to the *working plane*  $P_{fe}$  through the *cutting edge principal point* D.

**6.1.2 working engagement of the cutting edge  $a_{Se}$  or  $a_e^{1)}$**  (see figures 3 to 6 and 8): The *engagement of the cutting edge* with the workpiece measured in a direction parallel to the *working plane*  $P_{fe}$  and perpendicular to the *direction of feed motion* at the *cutting edge principal point* D.

**6.1.3 feed engagement of the cutting edge  $a_{Sf}$  or  $a_f^{1)}$**  (see figures 1 and 3 to 9): The *engagement of the cutting edge* with the workpiece in the *direction of feed motion* measured at the *cutting edge principal point* D.

iTeh STANDARDS PREVIEW  
(standards.iteh.ai)

## 7 The cut and its dimensions (see figure 9)

**7.1 the cut:** The layer of the workpiece material to be removed by a single action of a *cutting part*.

NOTE — A single action of a cutting part is considered to be either one passage of the cutting part through the workpiece, or the generation of one revolution of the *transient surface*.

**7.2 nominal cross-sectional area of the cut  $A_D$**  (see figures 1, 2 and 9): The actual area of the cross-section of the cut in the *cut dimension plane*  $P_D$  at the instant in time considered.

### NOTES

1 For practical purposes  $A_D$  is approximated as

$$A_D = a_p f_z \sin \varphi$$

where  $\varphi$  is the *feed motion angle*.

2 Whenever the cross-section of the cut or any other dimension is considered in another plane (for example, in the *tool face*), it should be clearly specified and indicated by an appropriate suffix.

**7.2.1 total cross-sectional area of the cut  $A_{Dtot}$**  (in the case of a multitoothed cutting tool): The sum of the individual cross-sectional areas of cut of all the *cutting parts* simultaneously engaged at a given instant in time.

1) Strictly speaking when referring to the single edge, the suffix S should be used, followed by the characteristic suffix of the direction considered. However, in order to avoid double suffixes, the letter S may be dropped whenever no confusion arises.

**7.2.2 nominal width of cut  $b_D$**  (see figures 1, 2a and 9): The distance between the two extreme points of the *active major cutting edge* profile measured in the *cut dimension plane*  $P_D$  at a given instant in time.

**7.2.3 nominal thickness of cut  $h_D$** : The ratio of the *cross-sectional area of the cut* and its *nominal width of cut*, both taken at the same instant in time:

$$h_D = A_D/b_D$$

**7.2.4 local thickness of cut  $h_i$  at a selected point on the cutting edge**: The dimension of the cut measured along the intersection of the *cutting edge normal plane*  $P_{ne}$  and the *working reference plane*  $P_{re}$  at the instant in time and point considered.

## 8 The pass and its dimensions

**8.1 pass**: The layer of workpiece material to be removed by a single passage of a cutting tool.

**8.2 cross-sectional area of the pass  $A_T$** : The actual area of the cross-section of the pass projected on a plane perpendicular to the *direction of feed motion*.

**9 material removal rate  $Q$** : The volume of material being removed per unit of time at a particular instant in time.

For all operations with rectilinear *feed motion*, the material removal rate of a *cutting tool* is given by

$$Q = A_T v_f$$

In the case of a multitoothed cutting tool, it may be desirable to consider the material removal rate of a particular *cutting part* in which case the material removal rate per tooth would be designated by  $Q_z$ .

In the case of turning,  $Q = Q_z$ , and can be approximated by

$$Q_z = A_D v_{cD}$$

NOTE – The value of  $v_{cD}$  is the *cutting speed* considered at the *cutting edge principal point D*.

# iTeh STANDARD PREVIEW (standards.iteh.ai)

[ISO 3002-3:1984](https://standards.iteh.ai/catalog/standards/sist/65a1c0df-3f92-47f1-a396-d79ac1f02546/iso-3002-3-1984)

<https://standards.iteh.ai/catalog/standards/sist/65a1c0df-3f92-47f1-a396-d79ac1f02546/iso-3002-3-1984>

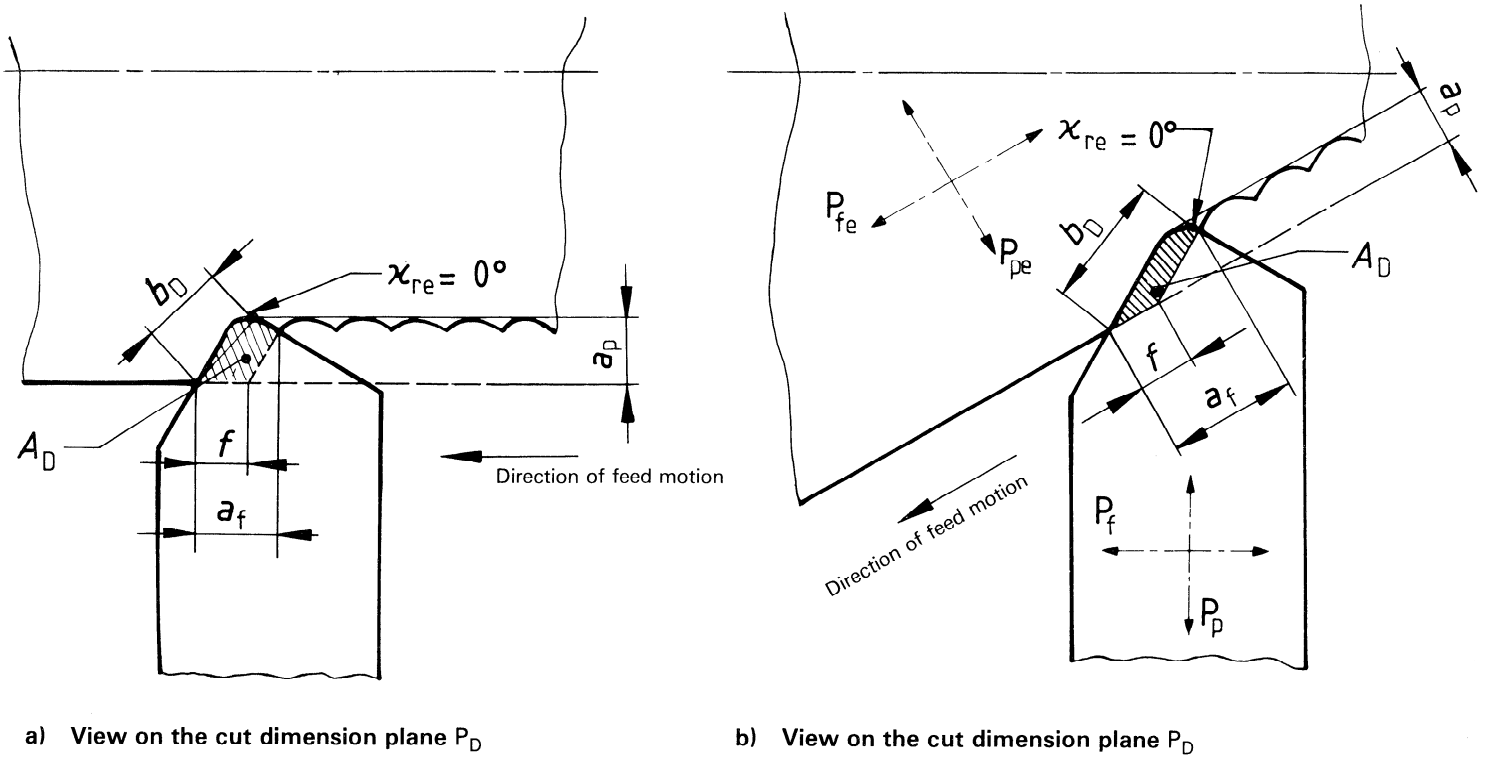

NOTE — In longitudinal turning  $\phi = 90^\circ$  and the feed is parallel to the plane  $P_D$ .

ITC STANDARD PREVIEW  
(standards.iteh.ai)

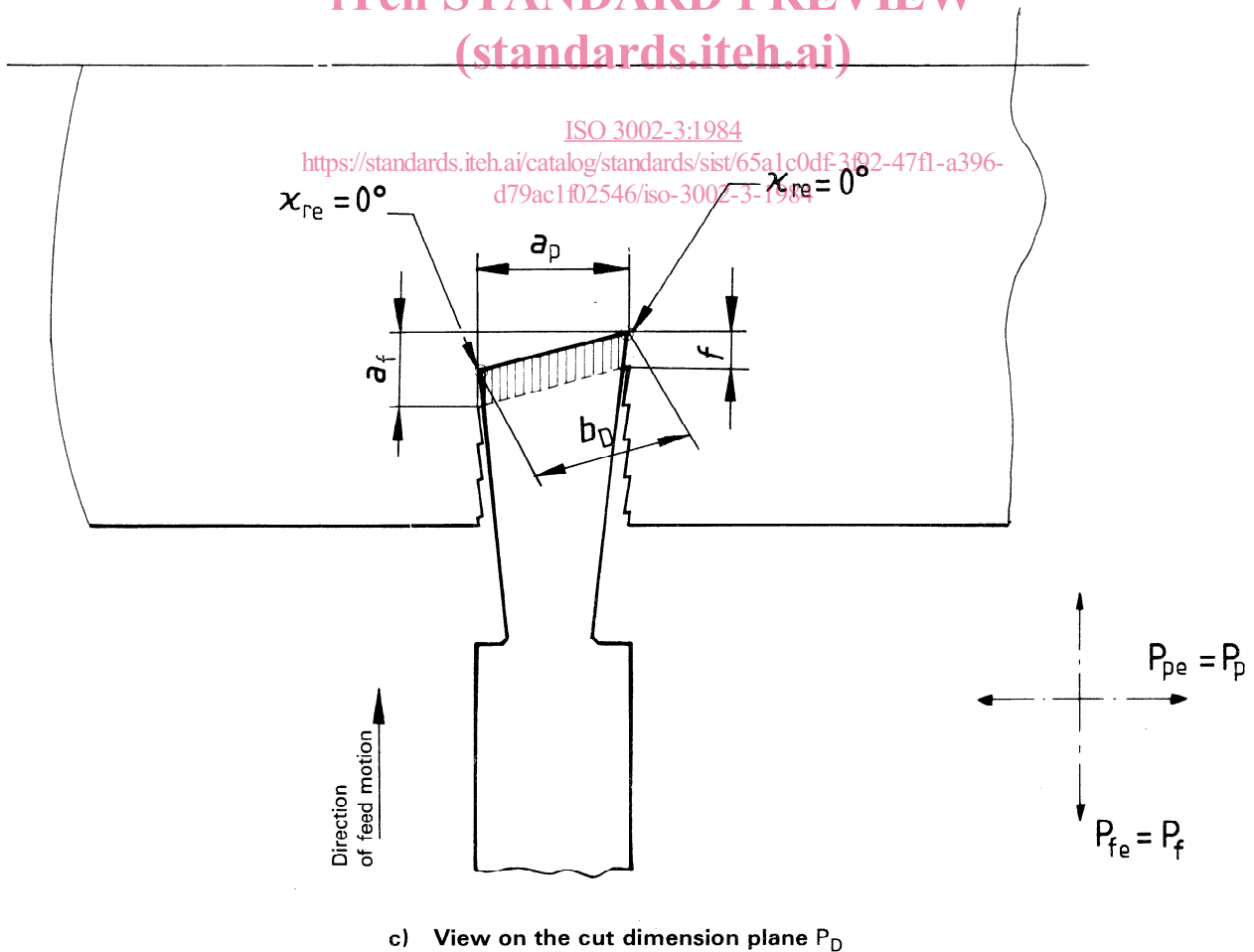

NOTE — This figure is only correct when the cutting edge principal point is at the height of the centre.

Figure 1 — Engagements, feed and dimensions of the cut in turning

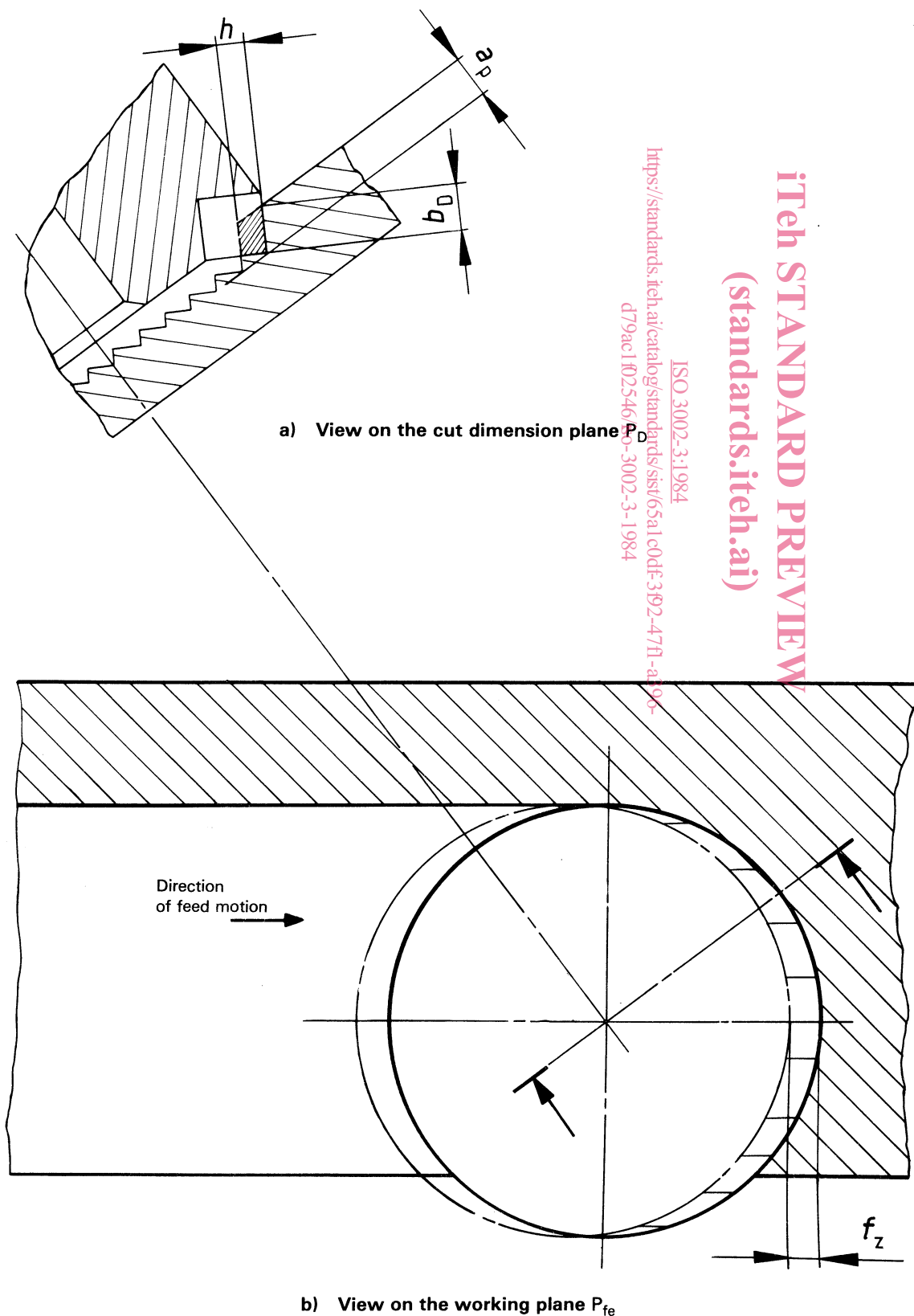

a) View on the cut dimension plane  $P_D$

b) View on the working plane  $P_{fe}$

Figure 2 – Engagements, feed and dimensions of the cut in milling

ISO 3002-3:1984  
<https://standards.iteh.ai/catalog/standards/siv/65a1c0df-392-47ff-a195-d79ac1025460-iso-3002-3-1984>

iteh STANDARD PREVIEW  
 (standards.iteh.ai)

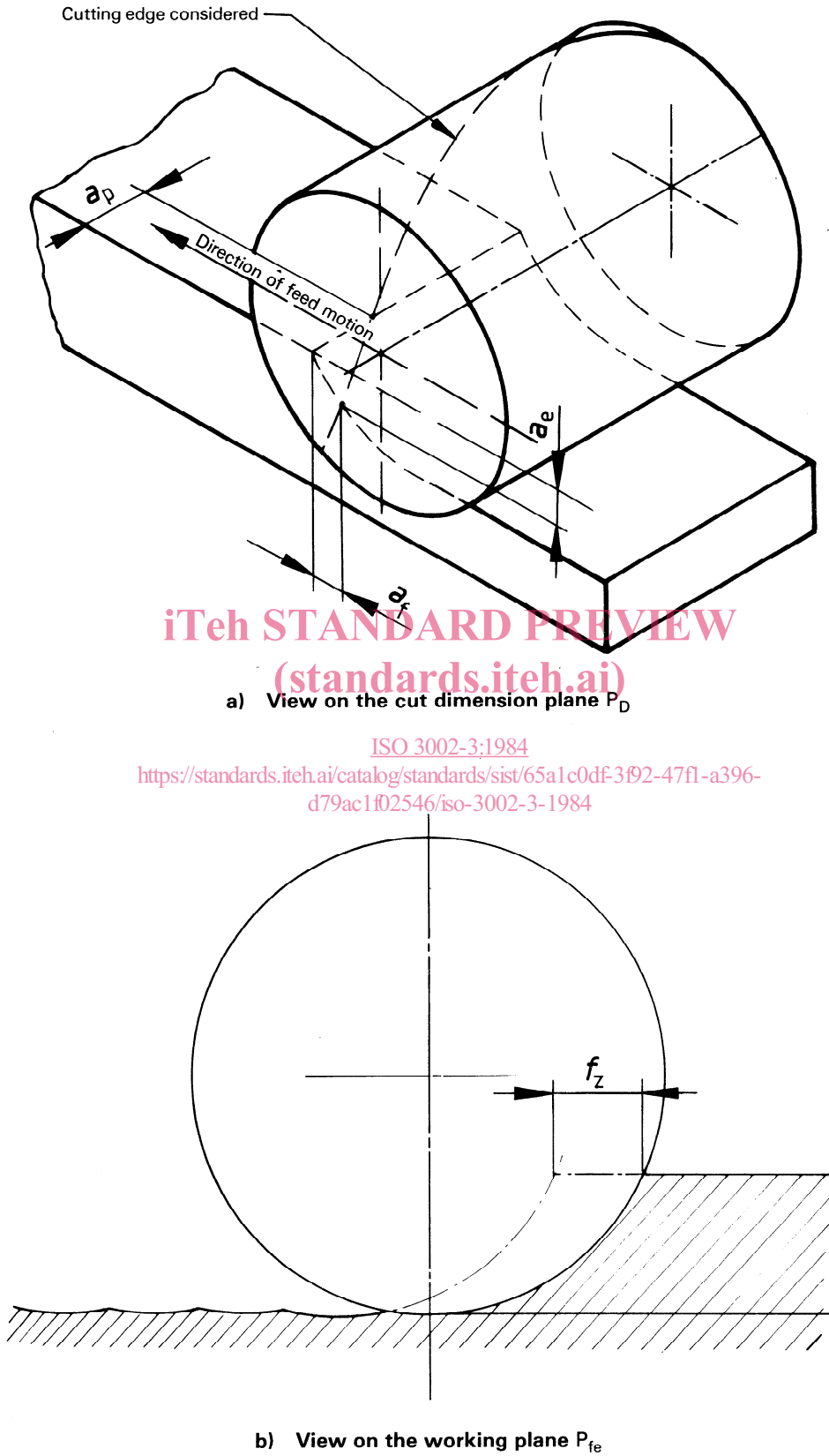
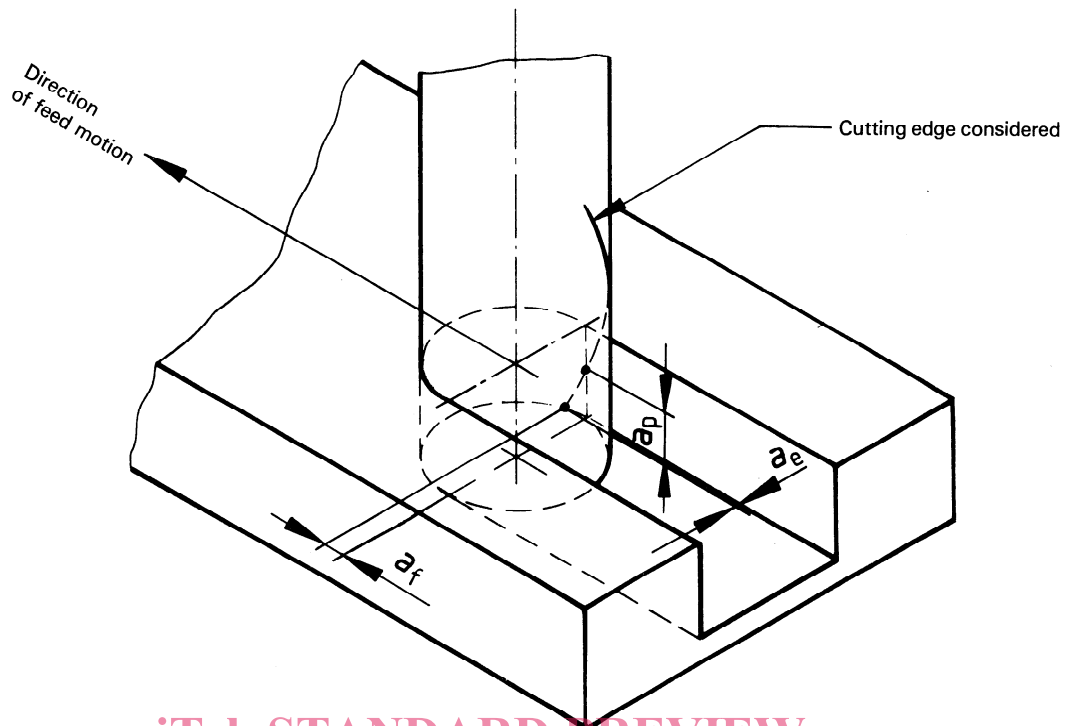

Figure 3 — Engagements, feed and dimensions of the cut in milling



iTeh STANDARD PREVIEW

Figure 4 – Engagements, feed and dimensions of the cut in milling

ISO 3002-3:1984

<https://standards.itih.ai/catalog/standards/sist/65a1c0df-3f92-47f1-a396-d79ac1f02546/iso-3002-3-1984>

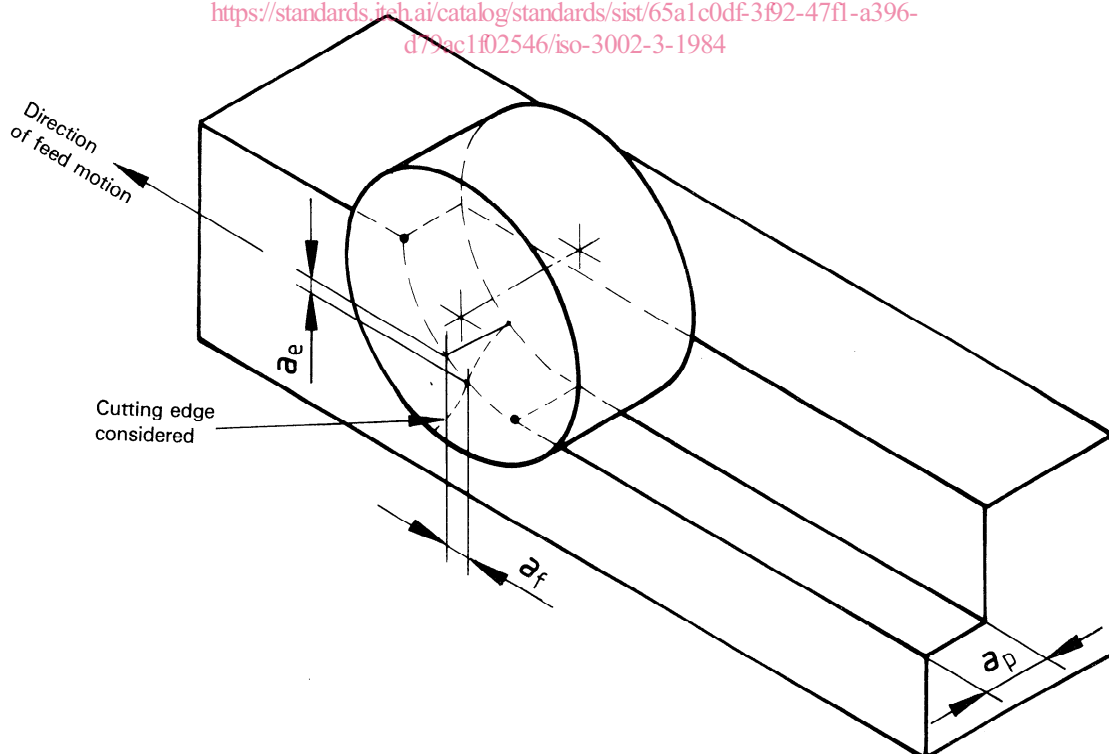

Figure 5 – Engagements, feed and dimensions of the cut in milling