



Designation: D6560 – 12



Designation: IP 143/01

Standard Test Method for Determination of Asphaltenes (Heptane Insolubles) in Crude Petroleum and Petroleum Products^{1,2}

This standard is issued under the fixed designation D6560; the number immediately following the designation indicates the year of original adoption or, in the case of revision, the year of last revision. A number in parentheses indicates the year of last reappraisal. A superscript epsilon (ϵ) indicates an editorial change since the last revision or reappraisal.

1. Scope*

1.1 This test method covers a procedure for the determination of the heptane insoluble asphaltene content of gas oil, diesel fuel, residual fuel oils, lubricating oil, bitumen, and crude petroleum that has been topped to an oil temperature of 260°C (see [A1.2.1.1](#)).

1.2 The precision is applicable to values between 0.50 and 30.0 % m/m. Values outside this range may still be valid but may not give the same precision values.

1.3 Oils containing additives may give erroneous results.

1.4 The values stated in SI units are to be regarded as standard. No other units of measurement are included in this standard.

1.5 *This standard does not purport to address all of the safety concerns, if any, associated with its use. It is the responsibility of the user of this standard to establish appropriate safety and health practices and determine the applicability of regulatory limitations prior to use.*

2. Referenced Documents

2.1 *ASTM Standards:*³

[D86 Test Method for Distillation of Petroleum Products at Atmospheric Pressure](#)

[D1298 Test Method for Density, Relative Density, or API Gravity of Crude Petroleum and Liquid Petroleum Products by Hydrometer Method](#)

[D4052 Test Method for Density, Relative Density, and API Gravity of Liquids by Digital Density Meter](#)

[D4057 Practice for Manual Sampling of Petroleum and Petroleum Products](#)

[D4177 Practice for Automatic Sampling of Petroleum and Petroleum Products](#)

2.2 *Energy Institute Standard:*⁴

[Specifications for IP Standard Thermometers](#)

3. Terminology

3.1 *Definitions:*

3.1.1 *asphaltenes, n*—(rarely used in the singular) — *in petroleum technology*, represent an oil fraction that is soluble in a specified aromatic solvent but separates upon addition of an excess of a specified paraffinic solvent.

3.1.1.1 *Discussion*—In this test method, the aromatic solvent is hot toluene and the paraffinic solvent is heptane.

3.1.1.2 *Discussion*—Historically, benzene was the aromatic solvent, but benzene is not typically used now for health reasons. The precision of this test method when using toluene has been found to be the same as when using benzene.

4. Summary of Test Method

4.1 A test portion of the sample is mixed with heptane and the mixture heated under reflux, and the precipitated asphaltenes, waxy substances, and inorganic material are collected on a filter paper. The waxy substances are removed by washing with hot heptane in an extractor.

4.2 After removal of the waxy substances, the asphaltenes are separated from the inorganic material by dissolution in hot toluene, the extraction solvent is evaporated, and the asphaltenes weighed.

5. Significance and Use

5.1 Asphaltenes are the organic molecules of highest molecular mass and carbon-hydrogen ratio normally occurring in crude petroleum and petroleum products containing residual

¹ This test method is under the jurisdiction of ASTM Committee D02 on Petroleum Products, Liquid Fuels, and Lubricants and is the direct responsibility of Subcommittee D02.14 on Stability and Cleanliness of Liquid Fuels.

Current edition approved April 15, 2012. Published May 2012. Originally approved in 2000. Last previous edition approved in 2005 as D6560-00(2005). DOI: 10.1520/D6560-12.

² This standard is based on material published in the *IP Standard methods for Analysis and Testing of Petroleum and Related Products and British Standard 2000 Parts*, copyright Energy Institute, 61 New Cavendish Street, London, W1M 8AR. Adapted with permission of Energy Institute.

³ For referenced ASTM standards, visit the ASTM website, www.astm.org, or contact ASTM Customer Service at service@astm.org. For *Annual Book of ASTM Standards* volume information, refer to the standard's Document Summary page on the ASTM website.

⁴ Available from Energy Institute, 61 New Cavendish St., London, W1M 8AR, UK.

*A Summary of Changes section appears at the end of this standard

material. They may give problems during storage and handling if the suspension of asphaltene molecules is disturbed through excess stress or incompatibility. They are also the last molecules in a product to combust completely, and thus may be one indicator of black smoke propensity. Their composition normally includes a disproportionately high quantity of the sulfur, nitrogen, and metals present in the crude petroleum or petroleum product.

6. Apparatus

6.1 *General*—Ground-glass joints from different sources may have one of two diameter to length ratios. For the purposes of this test method, either is suitable, and for some applications, the diameter itself can be one of two. However, it is critical that the male and female parts of each joint are from the same series to avoid recession or protuberance.

6.2 *Condenser*, with a coil or double surface, fitted with a 34/45 or 34/35 ground-glass joint at the bottom to fit the top of the extractor. Minimum length is 300 mm.

6.3 *Reflux Extractor*, conforming to the dimensions given in Fig. 1. Tolerances are ± 1 mm on the height and outer diameter (OD) of the extractor body and ± 0.5 mm on all other dimensions. The female ground-glass joint at the top shall match the male at the bottom of the condenser, and the male ground-glass joint at the bottom shall match the female of the conical flask.

6.4 *Conical Flasks*, of borosilicate glass of appropriate capacity (see 11.2 and Table 1), with ground-glass joints to fit the bottom of the extractor.

NOTE 1—Sizes 24/39, 24/29, 29/43, or 29/32 are suitable.

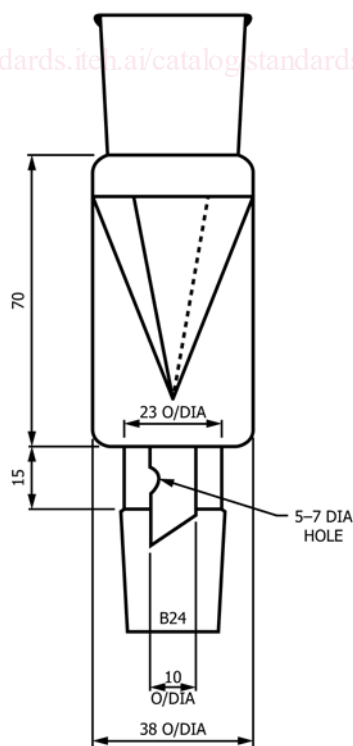

FIG. 1 Extractor

TABLE 1 Test Portion Size, Flask, and Heptane Volumes

Estimated Asphaltene Content % m/m	Test Portion Size g	Flask Volume mL	Heptane Volume mL
Less than 0.5	10 \pm 2	1000	300 \pm 60
0.5 to 2.0	8 \pm 2	500	240 \pm 60
Over 2.0 to 5.0	4 \pm 1	250	120 \pm 30
Over 5.0 to 10.0	2 \pm 1	150	60 \pm 15
Over 10.0 to 25.0	0.8 \pm 0.2	100	25 to 30
Over 25.0	0.5 \pm 0.2	100	25 \pm 1

6.5 *Stopper*, of borosilicate glass of a size to fit the conical flask.

6.6 *Evaporating Vessel*, of borosilicate glass. Either a hemispherical dish of approximately 90 mm diameter, or another suitable vessel used in conjunction with a rotovapor.

NOTE 2—A rotovapor in conjunction with a nitrogen atmosphere reduces the hazard of toluene evaporation (see 11.7).

6.7 *Filter Funnel*, of borosilicate glass, approximately 100 mm diameter.

6.8 *Filter Papers*, Whatman⁵ Grade 42, 110 or 125-mm diameter.

6.9 *Analytical Balance*, capable of weighing with an accuracy of 0.1 mg.

6.10 *Forceps*, of stainless steel, spade ended.

6.11 *Timing Device*, electronic or manual, accurate to 1.0 s.

6.12 *Oven*, capable of maintaining a temperature from 100 to 110°C.

6.13 *Graduated Cylinders*, of 50 and 100 mL capacity.

6.14 *Stirring Rods*, of glass or polytetrafluoroethylene (PTFE), 150 by 3-mm diameter.

6.15 *Cooling Vessel*, consisting of either a desiccator without desiccant, or another suitable tightly-stoppered vessel.

6.16 *Mixer*, high-speed, nonaerating.

7. Reagents

7.1 *Toluene (methylbenzene)* [C₆H₅CH₃], analytical reagent or nitration grade.

7.2 *Heptane* [C₇H₁₆], analytical reagent grade.

8. Sampling

8.1 Unless otherwise specified, take samples by the procedures described in Practice D4057 or D4177.

9. Test Portion Preparation

9.1 Test portions from the laboratory samples shall be drawn after thorough mixing and subdivision. Heat viscous samples of residual fuels to a temperature that renders the

⁵ The sole source of supply of the filter papers known to the committee at this time is Whatman Int. Ltd., Maidstone, UK. If you are aware of alternative suppliers, please provide this information to ASTM International Headquarters. Your comments will receive careful consideration at a meeting of the responsible technical committee,¹ which you may attend.

sample liquid, but not above 80°C, and homogenize, using the mixer (see 6.16) as necessary.

9.2 Heat samples of penetration grade bitumens to a temperature not exceeding 120°C, and stir well before taking an aliquot.

9.3 Samples of hard bitumens shall be ground to a powder before an aliquot is taken.

9.4 Samples of crude petroleum shall be prepared in accordance with the procedure described in the Annex A1, unless it is known that the crude petroleum contains negligible quantities of material boiling below 80°C.

10. Apparatus Preparation

10.1 Clean all glass flasks (see 6.4) and dishes (see 6.6) by a means that matches the cleanliness obtained by the use of a strongly oxidizing agent, such as chromosulfuric acid, ammonium peroxydisulfate in concentrated sulfuric acid at approximately 8 g/L, or sulfuric acid itself, soaking for at least 12 h, followed by rinses in tap water, distilled water, and then acetone, using forceps only for handling. (**Warning**—Chromosulfuric acid is a health hazard. It is toxic, a recognized carcinogen as it contains Cr (VI) compounds, which are highly corrosive and potentially hazardous in contact with organic materials. When using chromosulfuric acid cleaning solution, eye protection and protective clothing are essential. Never pipette the cleaning solution by mouth. After use, do not pour cleaning solution down the drain, but neutralize it with great care, owing to the concentrated sulfuric acid present, and dispose of it in accordance with standard procedures for toxic laboratory waste (chromium is highly dangerous to the environment). Nonchromium containing, strongly oxidizing acid cleaning solutions are also highly corrosive and potentially hazardous in contact with organic materials, but do not contain chromium, which has its own special disposal problems.)

10.2 For routine analysis, use a proprietary laboratory detergent to clean the glassware, followed by the rinses described in 10.1. When the detergent cleaning no longer matches the cleanliness required based on visual appearance, use a strong oxidizing agent.

10.3 After rinsing, place the glassware in the oven (see 6.12) for 30 min, and cool in the cooling vessel (see 6.15) for 30 min before weighing.

11. Procedure

11.1 Estimate the asphaltene content of the sample, or residue obtained from the procedure in Annex A1, and weigh the quantity, to the nearest 1 mg for masses above 1 g and to the nearest 0.1 mg for masses of 1 g and below (see Table 1), into a flask (see 6.4) of appropriate capacity (see Table 1).

11.2 Add heptane (see 7.2) to the test portion in the flask at a ratio of 30 mL to each 1 g of sample if the expected asphaltene content is below 25 % m/m. For samples with an expected asphaltene content of above 25 % m/m, a minimum heptane volume of 25 mL shall be used (see Table 1).

11.3 Boil the mixture under reflux for 60 ± 5 min. Remove the flask and contents at the end of this period, cool, close with

a stopper (see 6.5), and store in a dark cupboard for 90 to 150 min, calculated from the time of removal from reflux.

11.4 Place the filter paper, folded as shown in Fig. 2 (so as to prevent loss of asphaltenes by creeping), in the filter funnel, using forceps. Thereafter, handle the filter paper only with forceps. Without agitation, decant the liquid into the filter paper, and then transfer the residue in the flask as completely as possible with successive quantities of hot heptane, using the stirring rod (see 6.14) as necessary. Give the flask a final rinse with hot heptane, and pour the rinsings through the filter. Set the flask aside, without washing, for use as specified in 11.6.

11.5 Remove the filter paper and contents from the funnel, and place in the reflux extractor (see 6.3). Using a flask different from that used initially, reflux with heptane (see 7.2) at a rate of 2 drops/s to 4 drops/s from the end of the condenser for an extraction period of not less than 60 min, or until a few drops of heptane from the bottom of the extractor leave no residue on evaporation on a glass slide.

11.6 Replace the flask by the one used initially, and to which has been added 30 to 60 mL of toluene (see 7.1), and continue refluxing until all the asphaltenes have been dissolved from the paper.

11.7 Transfer the contents of the flask to a clean and dry (see Section 10) evaporating vessel (see 6.6), weighed to the nearest 0.2 mg by tare against a similar dish. Wash out the flask with successive small quantities of toluene to a total not exceeding 30 mL. Remove the toluene by evaporation on a boiling water bath, or by evaporation in a rotovapor under an atmosphere of nitrogen. (**Warning**—Perform the evaporation in a fume hood.)

11.8 Dry the dish and contents in the oven (see 6.12) at 100 to 110°C for 30 min. Cool in the cooling vessel (see 6.15) for 30 to 60 min and reweigh by tare against the dish used previously for this purpose, and which has been subjected to the same heating and cooling procedure as was the dish containing asphaltenes.

NOTE 3—Asphaltenes are very susceptible to oxidation, and it is important that the procedure specified in the final drying stage is adhered to exactly as regards to temperature and time ±1 min.

12. Calculation

12.1 Calculate the asphaltene content, A , in % m/m, of petroleum products as follows:

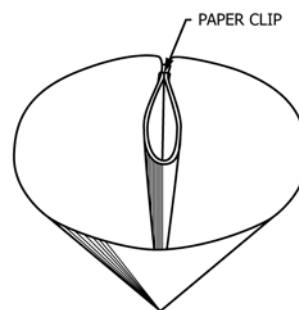

FIG. 2 Filter Paper