



Designation: F2638 – 12

# Standard Test Method for Using Aerosol Filtration for Measuring the Performance of Porous Packaging Materials as a Surrogate Microbial Barrier<sup>1</sup>

This standard is issued under the fixed designation F2638; the number immediately following the designation indicates the year of original adoption or, in the case of revision, the year of last revision. A number in parentheses indicates the year of last reapproval. A superscript epsilon ( $\epsilon$ ) indicates an editorial change since the last revision or reapproval.

## 1. Scope

1.1 This test method measures the aerosol filtration performance of porous packaging materials by creating a defined aerosol of 1.0  $\mu\text{m}$  particles and assessing the filtration efficiency of the material using either single or dual particle counters.

1.2 This test method is applicable to porous materials used to package terminally sterilized medical devices.

1.3 The intent of this test method is to determine the flow rate through a material at which maximum penetration occurs. The porous nature of some materials used in sterile packaging applications might preclude evaluation by means of this test method. The maximum penetration point of a particular material could occur at a flow rate that exceeds the flow capacity of the test apparatus. As such, this test method may not be useful for evaluating the maximum penetration point of materials with a Bendtsen flow rate above 4000 mL/min as measured by ISO 5636–3.

1.4 The values stated in SI units are to be regarded as the standard. The values given in parentheses are for information only.

1.5 *This standard does not purport to address all of the safety concerns, if any, associated with its use. It is the responsibility of the user of this standard to establish appropriate safety and health practices and determine the applicability of regulatory limitations prior to use.*

## 2. Referenced Documents

### 2.1 ASTM Standards:<sup>2</sup>

E177 Practice for Use of the Terms Precision and Bias in

<sup>1</sup> This test method is under the jurisdiction of ASTM Committee F02 on Flexible Barrier Packaging and is the direct responsibility of Subcommittee F02.15 on Chemical/Safety Properties.

Current edition approved May 1, 2012. Published June 2012. Originally approved in 2007. Last previous edition approved in 2007 as F2638 – 07. DOI: 10.1520/F2638-12.

<sup>2</sup> For referenced ASTM standards, visit the ASTM website, www.astm.org, or contact ASTM Customer Service at service@astm.org. For *Annual Book of ASTM Standards* volume information, refer to the standard's Document Summary page on the ASTM website.

### ASTM Test Methods

E691 Practice for Conducting an Interlaboratory Study to Determine the Precision of a Test Method

### 2.2 ISO Standard:<sup>3</sup>

ISO 5636–3 Paper and Board—Determination of Air Permeance (Medium Range)—Part 3: Bendtsen Method

## 3. Terminology

### 3.1 Definitions:

3.1.1 *challenge aerosol*—a sufficient quantity of aerosolized 1.0  $\mu\text{m}$  particles that enable effective particle counting in the filtrate aerosol.

3.1.2 *filtrate aerosol*—particles that remain aerosolized after passage through the test specimen.

3.1.3 *maximum penetration*—the highest percent concentration of particles in the filtrate aerosol when a specimen is tested over a range of pressure differentials or air flow rates.

### 3.2 Abbreviations and Symbols:

Symbol	Unit	Description
$C_S$	n	Average particle count of the challenge aerosol when using a single particle counter (Method A).
$C_F$	n	Average particle count of the filtrate aerosol.
$C_C$	n	Average particle count of the challenge aerosol.
$C_{LR}$	N	Average particle count of the filtrate aerosol prior to correction for dilution.
$R$	%	Percentage of particles from the challenge aerosol that remain in the filtrate aerosol.
$R_M$	%	The calculated maximum of $R$ .
$P_1$	cm WC	Pressure differential across a test specimen due to the air flow required by the particle counter.
$P$	cm WC	Pressure differential across a test specimen.
$F$	L/m/cm <sup>2</sup>	Air flow rate through the test specimen.
$F_1$	L/m/cm <sup>2</sup>	Air flow rate required by the particle counter when measuring the filtrate aerosol.
$F_M$	L/m/cm <sup>2</sup>	Air flow rate at which maximum penetration occurs.

## 4. Safety

4.1 The waste and the vacuum venturi vents for the test equipment described in this test method emit an aerosol of polystyrene particles and salt residues. These aerosols should

<sup>3</sup> Available from American National Standards Institute (ANSI), 25 W. 43rd St., 4th Floor, New York, NY 10036, http://www.ansi.org.

be exhausted from any enclosed environment or collected and filtered to remove all particles.

## 5. Summary of Test Method

5.1 A porous packaging material test specimen is placed in a sample holder in such a way as to create a filter between the challenge and filtrate aerosols. On the challenge side of the sample holder, an aerosol of particles is presented to the surface of the test specimen. An air flow is generated through the test specimen. A laser particle counter is used to monitor the particle concentrations in the challenge and filtrate aerosols. Particle concentrations will be measured over a range of flow rates in order to measure the percent penetration over the range of flow rates and determine the point of maximum penetration.

5.2 This test uses an aerosol of polystyrene latex particles (PSL) with a geometric mean particle diameter of 1.0  $\mu\text{m}$  and a standard deviation of less than 0.05  $\mu\text{m}$ .

5.2.1 A single particle counter may be used to sequentially measure the challenge and filtrate aerosols or two particle counters may be used to measure them continuously. When using a single particle counter the challenge and filtrate aerosols will be sequentially measured for each test flow rate. The filtrate aerosol concentration is reported as the average concentration of the filtrate aerosol over a time period of 45 to 60 s, beginning no sooner than 1 min from the start of the filtrate aerosol measurement. The challenge aerosol concentration is reported as the average concentration of the challenge aerosol over a time period of not less than 45 s, beginning no sooner than 1 min from the start of the challenge measurement. Challenge concentrations measured immediately before and after each filtrate concentration measurement are averaged to determine the challenge concentration for a given flow rate.

5.2.2 When using two particle counters, the challenge and filtrate aerosols are counted continuously by dedicated particle counters. The challenge and filtrate aerosol concentrations are reported as the average concentration of the challenge or filtrate aerosol over a time period of not less than 45 s, beginning no sooner than 1 min after a change in flow rate.

5.3 At the pressures used in this test, pressure differential across the sample and flow rate through the material are directly proportional. Pressure will be varied over a range that will ideally have at least two measurements at flow rates that are higher and lower than the flow rate that demonstrates the maximum penetration.

5.4 The reported results are the maximum penetration and the flow rate at which it occurs.

## 6. Significance and Use

6.1 This test method has been developed as a result of research performed by Air Dispersion Limited (Manchester, UK) and funded by the Barrier Test Consortium Limited. The results of this research have been published in a peer-reviewed

journal.<sup>4</sup> This research demonstrated that testing the barrier performance of porous packaging materials using microorganisms correlates with measuring the filtration efficiency of the materials.

6.2 This test method does not require the use of microbiological method; in addition, the test method can be conducted in a rapid and timely manner.

6.3 When measuring the filtration efficiency of porous packaging materials a typical filtration efficiency curve is determined (see Fig. 1). Since the arc of these curves is dependent upon the characteristics of each individual material, the appropriate way to make comparison among materials is using the parameter that measures maximum penetration through the material.

6.4 The particle filtration method is a quantitative procedure for determining the microbial barrier properties of materials using a challenge of 1.0  $\mu\text{m}$  particles over range of pressure differentials from near zero to approximately 30 cm water column (WC). This test method is based upon the research of Tallentire and Sinclair<sup>4</sup> and uses physical test methodology to allow for a rapid determination of microbial barrier performance.

## 7. Apparatus

7.1 *Test Fixture*—This consists of a base with associated valves, tubing, sample holder and clamps necessary to perform the test. Dimensioned drawings and arrangement of all components will be available in a future research report. Dimensions of the sample holder (Fig. 2) and schematics of the single particle counter (Fig. 3) and dual particle counter (Fig. 4) are shown. The significant components of the test fixture include:

7.1.1 *Sample Holder*—This consists of two assemblies, which form identical upper and lower manifolds and sample cavities that deliver a uniform flow of the aerosol or sweep air to the periphery of the test specimen while extracting it from the center.

7.1.2 *Normal Flow Range Needle Valve*, 500  $\mu\text{m}$  diameter maximum orifice.

7.1.3 *Low Flow Range Critical Orifice*, 40  $\mu\text{m}$  orifice.

7.2 *Aerosol Generator*—A conventional vertical style medical nebulizer is the preferred aerosol generator for use in a single counter system (Particle Measuring Systems PG100 or equivalent).

NOTE 1—Atomizer style nebulizers are not recommended unless used with a dual particle counter system as they exhibit sudden, unpredictable changes in aerosol concentration.

7.3 *Particle Counter*—The particle counter required for this test method must be capable of distinguishing between the residue from water droplets and the polystyrene latex (PSL) particles (Particle Measuring Systems Lasair series of counters or equivalent). The particle counter should have a flow demand that approximates the flow through the test specimen at

<sup>4</sup> "Definition of a Correlation Between Microbiological and Physical Particulate Barrier Performances for Porous Medical Packaging Materials," *PDA J Pharm Sci Technol*, Vol 56, No. 1, 2002, Jan-Feb, 11-9.

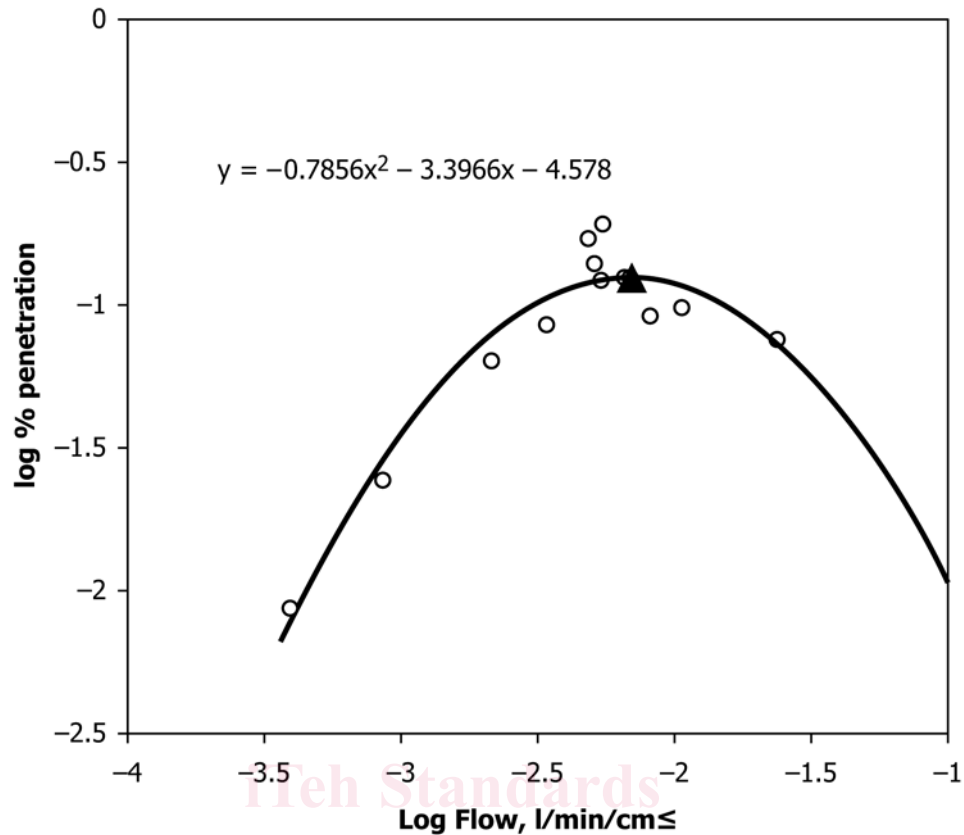

NOTE 1—The point of maximum penetration is indicated by the upward pointing triangle.

FIG. 1 A Typical Curve Showing Penetration as a Function of Flow Rate

maximum penetration. If the particle counter sorts particles by size, it must be determined in which size ranges the PSL particles reside.

7.4 *Data Logging*—The elapsed test time, the pressure differential, the total challenge particles, and/or the total filtrate particles shall be recorded every 6 s. When using the Lasair particle counters, the 1.0  $\mu\text{m}$  PSL particles are counted in both the 0.7 to 1.0  $\mu\text{m}$  and the 1.0 to 2.0  $\mu\text{m}$  size ranges. Therefore, both counts shall be recorded and totaled.

7.5 *Manometer*—A precision manometer with a minimum range of 0 to 5 cm (0 to 2 in.) WC and an accuracy of 0.005 cm (0.002 in.) WC to monitor the pressure difference across the sample.

7.6 *Pressure Regulator*—Precision regulator capable of delivering 1.0 standard litre per minute at pressures up to 3 bar.

7.7 *ULPA Filter*—Required to remove ambient particles.

7.8 *Buna N or Nitrile Rubber SAE Standard AS 568A Size-345 O-rings*—Provide a seal between the challenge and filtrate sides of the test.

## 8. Materials

8.1 Particle free, dry compressed air.

8.2 Tween 20 or sodium dodecylsulfate (SDS).

8.3 Concentrate suspension of 1  $\mu\text{m}$  PSL particles (Duke Scientific 3K1000, 5100A, and G0100 have all been found satisfactory).

8.4 Distilled water sufficiently free of dissolved material.

8.5 Porous packaging material.

## 9. Apparatus Preparation

9.1 Apparatus should be assembled as seen in Fig. 3 (single particle counter) or Fig. 4 (dual particle counter).

### 9.2 Material Preparation:

#### 9.2.1 Surfactant Solution:

9.2.1.1 Prepare a 0.02 % v/v solution of surfactant (Tween 20, SDS, or equivalent) in distilled water daily.

9.2.1.2 Aerosolize the surfactant solution and determine the particle size distribution of this solution by measuring the challenge aerosol. Ideally there should be no particles over 0.7  $\mu\text{m}$  in diameter detected. The aim is no more than 2 such particles detected within any 6-s period. Monitor surfactant solution for 1 min.

9.2.1.3 Table 1 is an example of the size distribution of surfactant solution suitable for use, each row being a 6-s counting interval.

#### 9.2.2 Particle Suspension:

9.2.2.1 Prepare a suspension of 1  $\mu\text{m}$  PSL particles in the surfactant solution described above.

NOTE 2—This solution is to be made fresh daily. When making the suspension from a highly concentrated source (such as Duke Scientific 5100A) some of the particles will have agglomerated into aggregates consisting of multiple particles. To ensure the aerosol consists of particles having only one PSL particle, place the bottle containing the solution in an ultrasonic bath for 15 s. This will disassociate the particles.

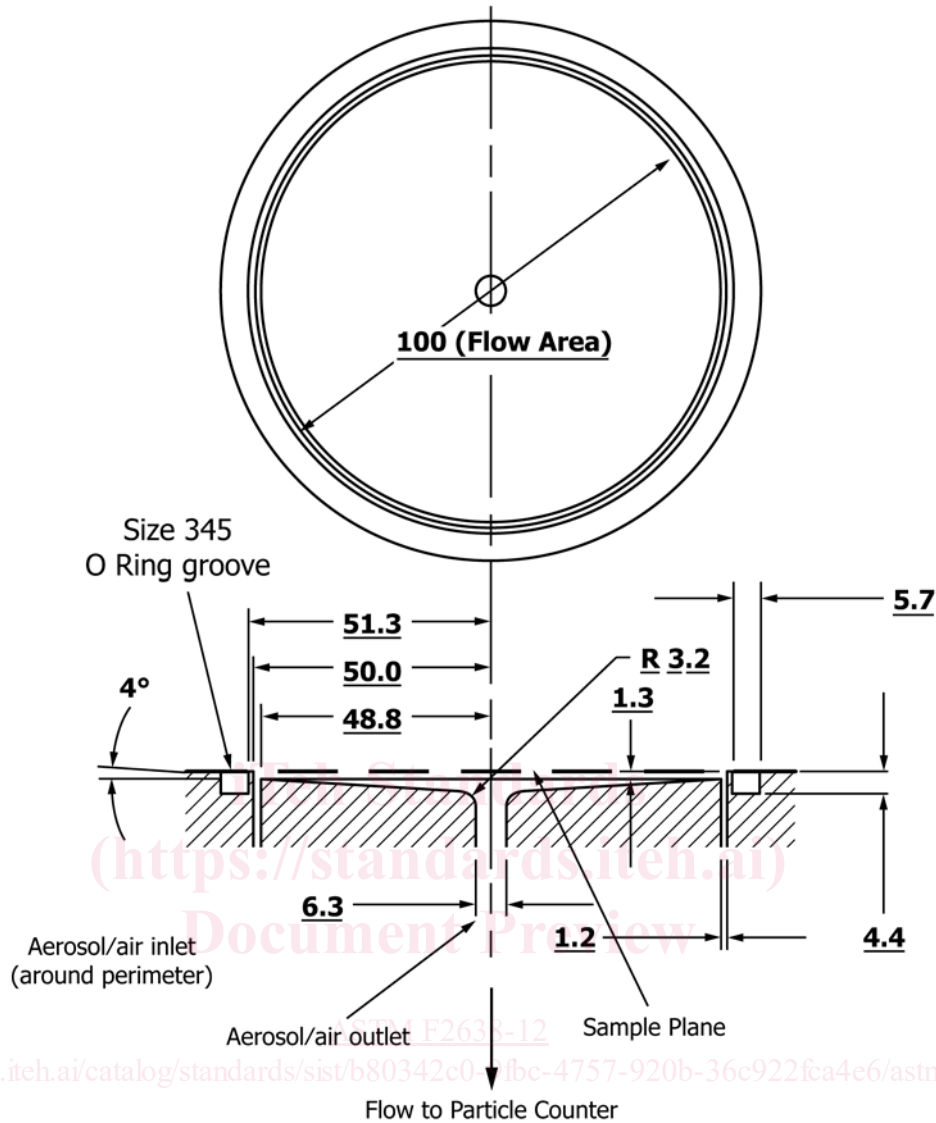

NOTE 1—Dimensions of the cavity in mm. The configuration of the top and bottom cavity is identical.

FIG. 2 Dimensions of the Sample Cavity

9.2.2.2 Check for particle concentration by monitoring counts in particle counter for 1 min without any sample in sample holder. The resulting challenge aerosol particle concentration must be within the range of 200 to 8000 particles per cc (this is equal to 600 to 24 000 counts per 6-s interval in a Lasair 1003).

9.2.2.3 Check for instrument bias by measuring the challenge counts with the test specimen in place. Then remove the specimen and measure filtrate results. Check that the counts differ by no more than 3 %.

NOTE 3—If concentrations higher than 8000 particles per cc are used, there will be significant errors due to coincidence (counting two particles as a single particle) in the particle counter detector.

## 10. Sample Preparation

10.1 Cut a sample of porous barrier material no less than 120 mm (the area of the sample exposed to the aerosol is 100 mm in diameter) in any dimension so that it completely covers

the O-ring in the lower half of the sample holder. The sample must cover the entire circumference of the seal O-ring. Critical dimensions of the exposure chamber are shown in Fig. 2.

## 11. Test Procedures

11.1 *Method A Single Particle Counter*—Procedure when using a single particle counter. Fig. 5 shows an example of the particle count results of a typical single measurement with readings every 6 s.

11.1.1 When only a single particle counter is in use, it must be switched between the challenge and filtrate aerosol. Therefore, an estimate must be made of the challenge aerosol concentration at the time of the filtrate measurement.

11.1.2 Set up equipment for 1 particle counter mode, use 0.7 to 1.0 μm and 1.0 to 2.0 μm bin data, record Lasair and manometer data every 6 s. Record pressure drop across sample during each 6-s sample length while counting particles in filtrate stream.

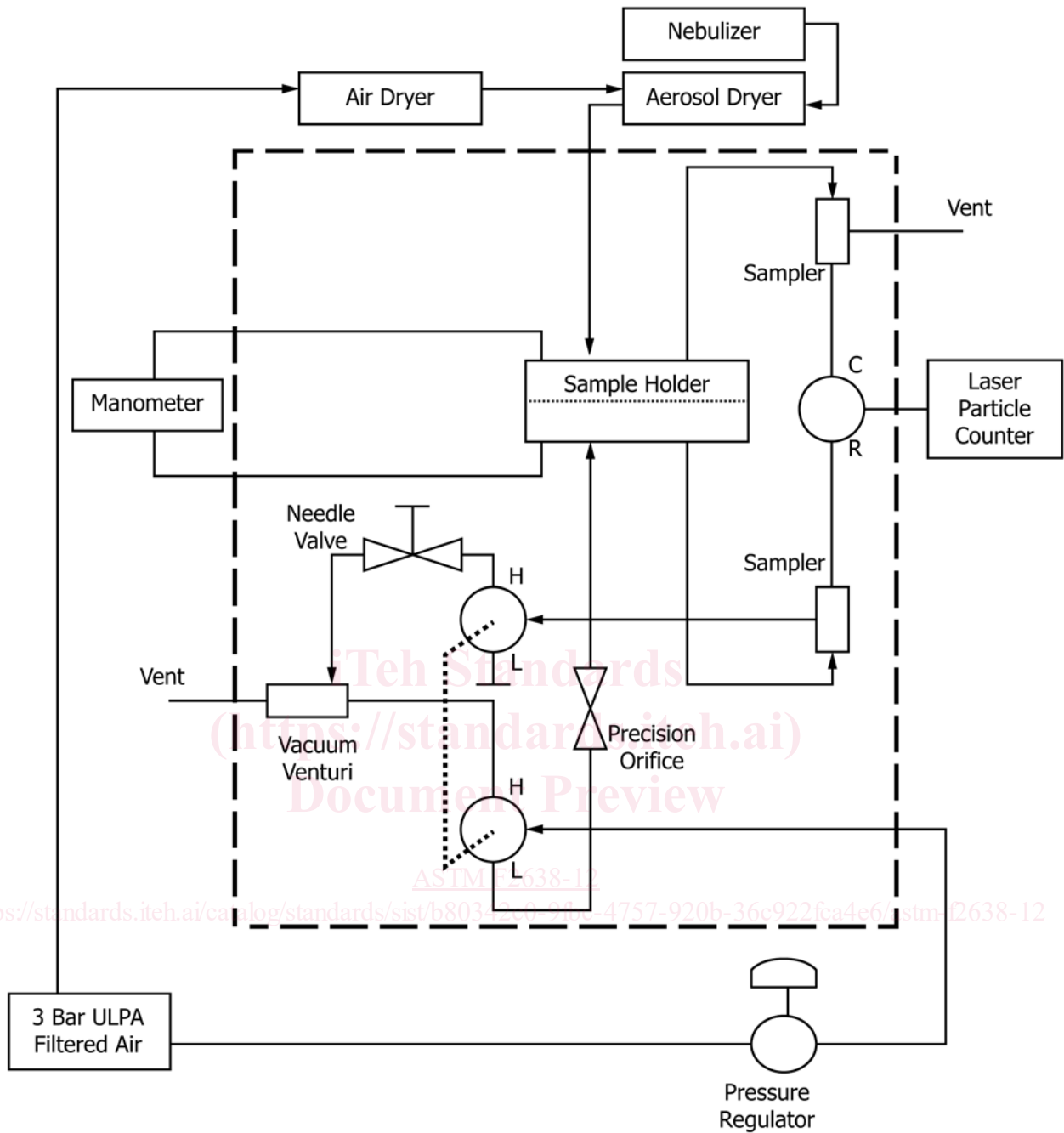

FIG. 3 Equipment Configuration for a Single Particle Counter—Method A

11.1.3 Test distilled water/surfactant to ensure water is clean as described in 9.2.1.

11.1.4 Prepare appropriate concentration (200 to 8000 particles/mL) of PSL suspension and confirm that the particle counts are within 3 % as described in 9.2.2.3.

11.1.5 Open sample holder and place sample in the sample holder.

11.1.6 Select High Flow Range.

11.1.7 Start aerosol flow, set Particle Counter to count Challenge.

11.1.8 Close the venturi needle valve and increase inlet air pressure to 3 bar, open the needle valve until pressure differ-

ential across the sample is 2 cm WC. Allow system to stabilize for at least 1 min before collecting challenge counts for no less than 45 s (45 to 60 s). Set the particle counter to Filtrate. Allow the system to stabilize for at least 2 min before collecting filtrate counts for no less than 45 s (45 to 60 s) and record pressure. Set the particle counter back to Challenge, allow the system to stabilize for at least 1 min before collecting challenge counts again for no less than 45 s (45 to 60 s).

11.1.9 Adjust the venturi needle valve to reduce the pressure differential across the sample by a factor of 2. If challenge particles have not just been counted, collect data for no less than 45 s (45 to 60 s). Set the particle counter to Filtrate. Allow

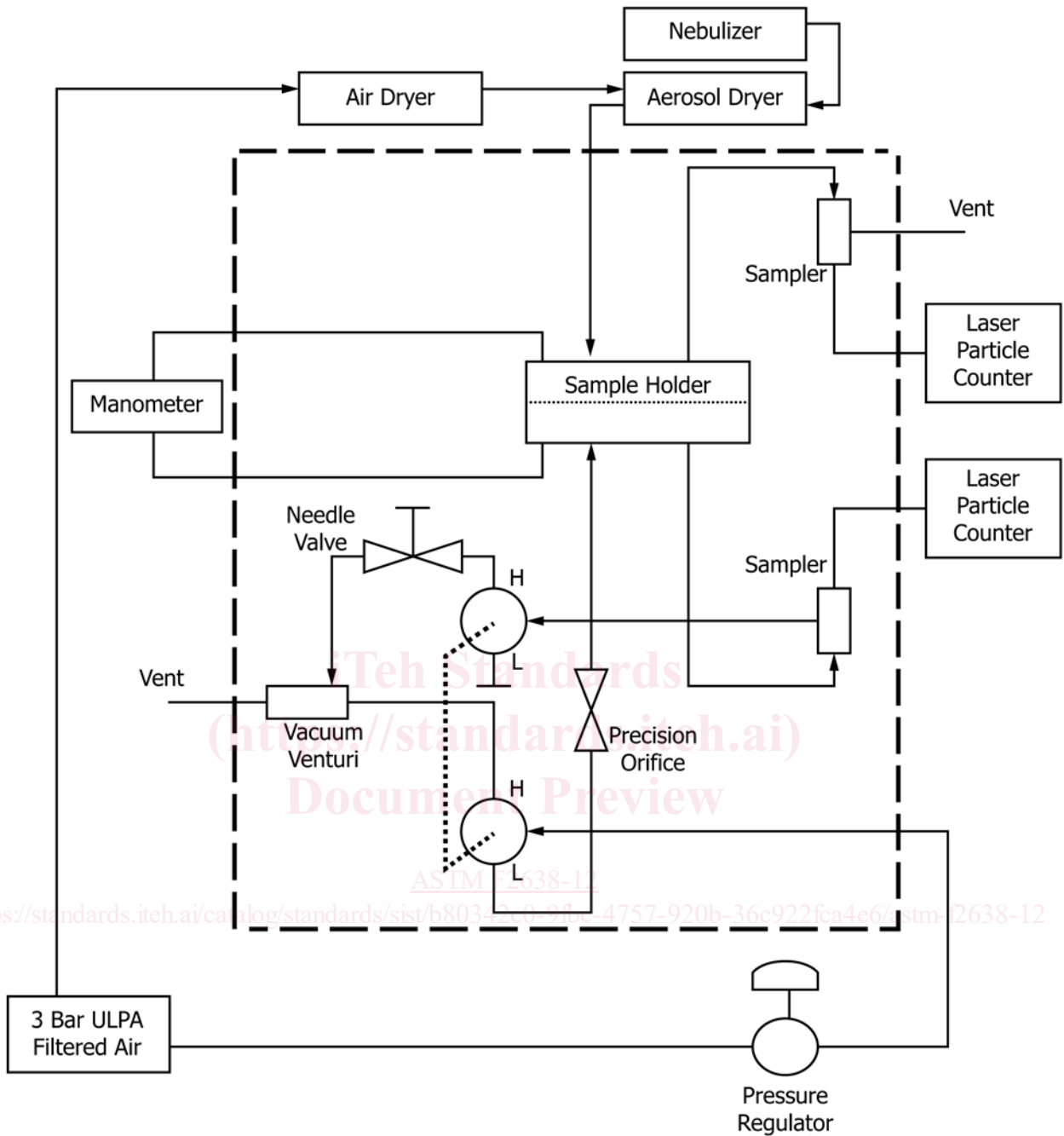

FIG. 4 Equipment Configuration for Dual Particle Counters—Method B

TABLE 1 Example of Particle Counts Generated from 0.02 % Surfactant in Acceptably Clean Distilled Water

0.1 µm	0.2 µm	0.3 µm	0.4 µm	0.5 µm	0.7 µm	1.0 µm	2.0 µm
852	176	36	19	4	0	0	0
879	179	45	15	2	1	0	0
808	155	38	12	1	0	0	0
802	176	37	14	2	0	0	0
828	178	37	14	1	0	0	0

the system to stabilize for at least 2 min before collecting filtrate counts for no less than 45 s (45 to 60 s) and record

pressure. Set the particle counter back to Challenge, allow the system to stabilize for at least 1 min before collecting challenge counts again for no less than 45 s (45 to 60 s). Continue to reduce pressure differential by a factor of 2 until a maximum penetration value has been detected or the venturi needle valve is closed. The pressure differential may be adjusted to the next value during the second count of challenge particles. If maximum penetration value has not been reached, record pressure differential ( $P_1$ ) with the venturi needle valve closed prior to switching to the Low Flow Range.