



Designation: D7672 – 11b^{ε1}

Standard Specification for Evaluating Structural Capacities of Rim Board Products and Assemblies¹

This standard is issued under the fixed designation D7672; the number immediately following the designation indicates the year of original adoption or, in the case of revision, the year of last revision. A number in parentheses indicates the year of last reapproval. A superscript epsilon (ϵ) indicates an editorial change since the last revision or reapproval.

^{ε1} NOTE—Language was changed editorially in June 2012.

INTRODUCTION

Rim board assemblies are an engineered component within light-frame wood platform construction. Rim board assemblies may serve in multiple structural capacities, including: providing floor closure and diaphragm attachment, transferring vertical and in-plane lateral loads, restricting out-of-plane rotation and lateral translation at the ends of the floor joists, providing deck ledger attachment, and spanning wall openings as a header material. Rim board products, which serve a principal role as a component integrated within a rim board assembly, can vary by wood species, size, shape, and type. Rim board products and assemblies require evaluation of their mechanical properties, physical properties, and their response to end use environments. Procedures established in this Specification provide a means to test rim board products and assemblies, to judge their acceptability, and to establish allowable design capacities.

1. Scope

1.1 This specification provides procedures for testing and establishing the structural capacities of proprietary rim board products and assemblies for use in light-frame wood construction using I-joist or structural composite lumber joist framing. This specification does not apply to commodity rim board products.

1.2 This specification was developed in light of currently manufactured panel, structural composite lumber, and pre-fabricated I-joist rim board products as defined in 3.2. Materials that do not conform to the definitions of 3.2 are beyond the scope of this specification.

1.3 Fire safety, sound transmission, building envelope performance, and cutting/notching attributes of rim board products and assemblies are all items that may need to be considered in an end-use application. These items fall outside the scope of this specification.

1.4 This specification primarily considers end use in dry service conditions, such as most protected framing members, where the equilibrium moisture content for solid-sawn lumber is less than 16 %.

1.5 This specification provides methods to establish “allowable stress” design resistances for use with the National Design Specification for Wood Construction (NDS). Derivation of design resistances from the test data in accordance with “load and resistance factor design” or “limit states design” are beyond the scope of this specification.

1.6 Quality control requirements are outside the scope of this Specification.

1.7 The performance of a rim board product will be affected by the constituent wood species, geometry, adhesive, and production parameters. Therefore, rim board products produced by each individual manufacturer shall be evaluated to determine their product properties, regardless of the similarity in characteristics to products produced by other manufacturers.

1.8 Where a manufacturer produces product in more than one facility, each production facility shall be evaluated independently. For additional production facilities, any revisions to the full qualification program in accordance with this specification shall be approved by an accredited, independent qualifying agency.

1.9 The values stated in inch-pound units are to be regarded as standard. The values given in parentheses are mathematical conversions to SI units that are provided for information only and are not considered standard.

1.10 *This standard does not purport to address all of the safety concerns, if any, associated with its use. It is the*

¹ This specification is under the jurisdiction of ASTM Committee D07 on Wood and is the direct responsibility of Subcommittee D07.05 on Wood Assemblies.

Current edition approved Dec. 1, 2011. Published January 2012. Last previous edition approved in 2011 as D7672–11a. DOI: 10.1520/D7672–11bE01.

responsibility of the user of this standard to establish appropriate safety and health practices and determine the applicability of regulatory limitations prior to use.

2. Referenced Documents

2.1 *ASTM Standards:*²

- D9 Terminology Relating to Wood and Wood-Based Products
- D198 Test Methods of Static Tests of Lumber in Structural Sizes
- D1037 Test Methods for Evaluating Properties of Wood-Base Fiber and Particle Panel Materials
- D2395 Test Methods for Specific Gravity of Wood and Wood-Based Materials
- D2915 Practice for Sampling and Data-Analysis for Structural Wood and Wood-Based Products
- D4442 Test Methods for Direct Moisture Content Measurement of Wood and Wood-Base Materials
- D4761 Test Methods for Mechanical Properties of Lumber and Wood-Base Structural Material
- D5055 Specification for Establishing and Monitoring Structural Capacities of Prefabricated Wood I-Joists
- D5456 Specification for Evaluation of Structural Composite Lumber Products

D7033 Practice for Establishing Design Capacities for Oriented Strand Board (OSB) Wood-Based Structural-Use Panels

F1667 Specification for Driven Fasteners: Nails, Spikes, and Staples

2.2 *Other Standards:*

- NDS ANSI/AF&PA National Design Specification for Wood Construction
- ANSI/ASME Standard B18.2.1
- ANSI/APA PRR-410 Standard for Performance-Rated Engineered Wood Rim Boards
- ICC-ES AC124 ICC Evaluation Service Acceptance Criteria for Rim Board Products
- PS-1 U.S. Product Standard, Structural Plywood
- PS-2 U.S. Product Standard, Performance Standard for Wood-Based Structural Use Panels

3. Terminology

3.1 *Definitions*—Standard definitions of wood terms are given in Terminology D9.

3.2 *Definitions of Terms Specific to This Standard:*

3.2.1 *Rim Board Assembly*—An assemblage of framing, sheathing, and fasteners at the boundary of a platform floor or roof framed with joists. **DISCUSSION:** The rim board assembly, as illustrated in Fig. 1 for a floor, consists of the sheathing, rim board, wall plate framing, the ends of any perpendicular (Fig. 1A) or parallel (Fig. 1B) joists, and the variety of fasteners that hold these components together.

² For referenced ASTM standards, visit the ASTM website, www.astm.org, or contact ASTM Customer Service at service@astm.org. For *Annual Book of ASTM Standards* volume information, refer to the standard's Document Summary page on the ASTM website.

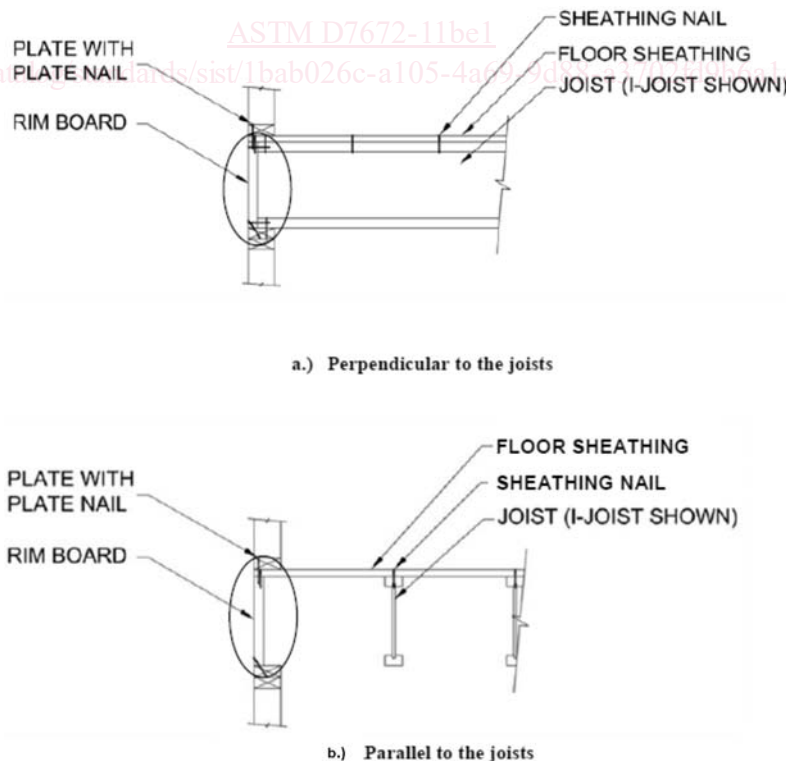

FIG. 1 Typical Rim Board Assembly Sections for Floor Framing

3.2.2 *Rim Board*—The component of a rim board assembly that provides in-plane lateral and vertical load path continuity, stability, and closure for the full depth of the joist space. **DISCUSSION:** As depicted in Fig. 1 and Fig. 2, the longitudinal axis runs parallel to the wall or foundation framing that supports the platform edge. The product depth extends vertically between the floor platform sheathing above and the wall or foundation plate beneath the platform. The rim board product provides vertical load transfer and lateral load transfer through the diaphragm boundary. It works with the sheathing and plate materials to restrain the rotation and lateral translation of the perpendicular floor joists at their end bearing locations. Except when used in a qualified header or cantilever application, the rim board bears upon the wall or foundation plate beneath the platform for the full length and thickness of the product.

3.2.3 *Commodity Rim Board*—Products manufactured to a rim board standard with commodity product capacities and predetermined grades that are qualified and used by multiple manufacturers. **DISCUSSION:** Commodity rim board products are not addressed by this standard.

NOTE 1—ANSI/APA PRR-410 is an example of a commodity rim board standard.

3.2.4 *Rectangular Wood-Based Rim Board*—A structural composite lumber, oriented strand board, or plywood rim board with a rectangular cross section.

3.2.5 *I-joist Rim Board*—A pre-fabricated I-joist rim board.

4. Materials

4.1 *General*—As a condition to being qualified in accordance with this Specification, a rim board product shall comply with the requirements and application limitations of Section 4.

4.2 *Header Applications*—Only rim board qualified for in-plane bending shall be permitted to span a wall opening, foundation opening, or extend beyond a lower wall to support a cantilevered framing offset at the rim board elevation in the structure. Rim board used as a header or cantilever shall be designed for the application using the qualified design properties established in accordance with the reference standards of 4.4. Otherwise, the rim board shall be continuously supported for the full length and thickness of the product.

4.3 *Fastener Capacities*—Rectangular wood-based rim boards and the flanges of I-joist rim boards shall have established capacities for fasteners inserted parallel with the X and Y orientations of Fig. 2. Minimum allowed spacings shall be set to prevent unusual splitting of the rim board. Fastener

capacities are required to be developed that address (1) connection of the diaphragm to the top edge of the rim board; (2) attachment of the rim board to wall plates above and below; (3) attachment of the rim board to the joist ends; (4) attachment of exterior wall siding to the rim board; and (5) attachment of any required hardware to the face. While it is permissible to develop most of these capacities based upon the material properties established in 4.4 and the relevant design provisions of the NDS, the in-plane lateral load capacity of the rim assembly shall be empirically established as outlined in this Specification. If the rim board assembly with a rectangular wood-based rim board is to be additionally qualified to support an exterior deck ledger, then deck ledger fastener attachments must also be developed. The procedure outlined in this Specification can be used for the qualification of deck ledger attachments. Alternative deck ledger attachment qualification procedures may be used in lieu of those contained within this specification provided that they consider all potential failure modes, including deck ledger splitting perpendicular-to-grain.

4.4 Product Specific Requirements :

4.4.1 *I-joist Rim Board Products*—I-joist rim board products must be qualified as an I-joist framing material in accordance with Specification D5055, have a minimum flange width of 1.5 in. (38 mm), and a minimum manufactured length of 8 ft. (2.4 m). I-joists with sawn lumber flanges shall have established fastener capacities into the face and edge that comply with the provisions of the NDS. I-joists with structural composite lumber flanges shall have fastener capacities established in accordance with Specification D5456. Deck ledger attachments to I-joist rim board products fall outside the scope of this specification.

4.4.2 *Rectangular Wood-Based Rim Boards*—Rectangular wood-based rim board products shall have a minimum thickness of 1.0 in. (25 mm) and a minimum manufactured length of 8 ft. (2.4 m). Additionally, they shall satisfy the following.

4.4.2.1 *Structural Composite Lumber*—Structural composite lumber rim board products shall be made from a material qualified in accordance with Specification D5456. The axial tension and compression capacities need not be qualified for rim board applications unless the product will be permitted to be used as a drag strut or diaphragm chord. SCL rim board products shall have fastener capacities into the edge and face established in accordance with Specification D5456. Where a Specification D5456 test method requires minimum specimen dimensions that exceed the product thickness, testing the rim board with its actual thickness shall be permitted.

4.4.2.2 *Proprietary Plywood and Oriented Strand Board*—Proprietary plywood and oriented strand board rim board products shall be initially qualified in accordance with PS-1 or PS-2. In addition, when used as a structural header, the edgewise bending performance of proprietary plywood and oriented strand board rim board products shall be evaluated in accordance with the Specification D5456 requirements for laminated veneer lumber or oriented strand lumber, respectively. This evaluation shall include, but is not limited to, relevant considerations applicable to edgewise bending, such as edgewise flexure, shear, and bearing design load establishment, duration of load, volume effects, moisture

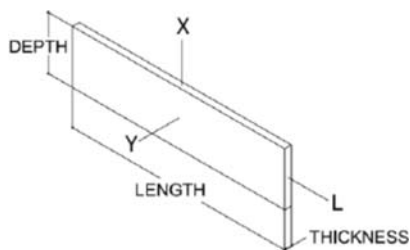

FIG. 2 Orientation for Rim Board

content, etc. The axial tension and compression capacities need not be qualified in accordance with Specification **D5456** for rim board applications unless the product will be used as a drag strut or diaphragm chord. Where a Specification **D5456** specified test method requires minimum specimen dimensions that exceed the product thickness, testing the rim board with its actual thickness shall be permitted. Proprietary plywood and OSB rim board products shall have fastener capacities into the edge and face that either comply with published values in the NDS or have been developed in accordance with Practice **D7033**.

5. Qualification

5.1 *General*—This section describes procedures, both empirical and analytical, for initial qualification of the structural capacities of rim board products and assemblies. Qualification is required for typical details of rim board application since they are used commonly and influence structural capacities.

5.2 *Qualification Process*—Rim board products shall be tested in accordance with Section 6 and evaluated in accordance with Section 7. The allowable design values and durability targets shall comply with the limitations specified by **Table 1**.

5.2.1 When deck ledger attachments are qualified for rectangular wood-based rim board products using the procedure outlined in this specification, they shall comply with the limitations specified in **Table 2**.

5.2.2 When a manufacturer chooses not to establish a concentrated vertical load capacity in accordance with the provisions 6.3 and 7.3, then squash blocks or alternative detailing provisions shall be provided to address concentrated load transfer through the rim board assembly.

5.3 *Sampling*—Samples for qualification testing shall be representative of the population being evaluated. When a modification to the manufacturing process results in a reduction in properties, new qualification testing is required. Sampling of the test material shall be done in accordance with the applicable portions of Section 3, “Statistical Methodology,” of Practice **D2915**.

5.4 *Witnessing*—Qualification tests shall be conducted or witnessed by a qualified agency in accordance with Section 8. All test results are to be certified by an accredited, independent qualifying agency.

5.5 *Moisture Content and Density*—Moisture content shall be measured and reported for each rim board product specimen tested in the qualification program in accordance with Test Methods **D4442**. The moisture content of other assembly components does not need to be determined. As an alternative to testing a full cross-section, only the moisture content of the flange materials needs to be tested for I-joint rim board products. Specific gravity shall be measured and reported for rectangular rim board products in accordance with Test Methods **D2395**. As an alternative, product density may be reported based upon the specimen weight divided by the specimen volume at the tested moisture content.

5.6 *Test Equipment Tolerances*—Tests in accordance with this specification are to be conducted using a machine or apparatus calibrated in accordance with Practices E4.

6. Mechanical Testing

6.1 *Uniform Vertical Load Transfer*—The uniform vertical load transfer capability of the rim board assembly is based upon the X-orientation compressive capacity of the rim board

ASTM D7672-11b e1

<https://standards.iteh.ai/catalog/standards/sist/1bab026c-a105-4a69-9d88-a3702fd9b6a1/astm-d7672-11b e1>

TABLE 1 Assembly Limitations

Minimum Rim Board Thickness ^A	Uniform Vertical Load Transfer Design Capacity (X direction)		Lateral Load Transfer Design Capacity (L direction)		Minimum Retained Lateral Load Transfer Durability ^B	Maximum Average Thickness Swell ^C
	Minimum ^D	Maximum	Minimum	Maximum ^E		
1.0 in. (25 mm)				190 plf (2.77 kN/m)		
1.125 in. (29 mm)	2000 plf	360 psi (2.48 N/mm ²)	180 plf	220 plf (3.21 kN/m)	75 %	10 %
1.25 in. (32 mm) and greater	(29.2 kN/m)	x rim board thickness ^F	(2.63 kN/m)	Not Limited		

^A For the purposes of this table, the thickness of I-joint rim board is the flange width.

^B The retained lateral load transfer durability is the ratio of the average durability lateral load transfer capacity divided by the dry lateral load transfer capacity as outlined in 7.5.

^C The thickness swell requirements apply only to rectangular rim board products. The average calculated thickness swell for all specimens from a five-panel sample originally conditioned in accordance with 6.4.2 shall not exceed 10 % and no individual value may be more than 12 %.

^D Lower uniform vertical load capacities are permitted to be qualified when the product is limited to engineered construction.

^E For rim board productions having a thickness between 1 in. (25 mm) and 1.25 in. (32 mm), the allowable capacity shall be interpolated between the following values:

1.0 in. (25 mm)	190 plf (2.77 kN/m)
1.125 in. (29 mm)	220 plf (3.21 kN/m)
1.25 in. (32 mm)	240 plf (3.50 kN/m)

The 240 plf (3.50 kN/m) capacity for 1.25-in. thick (32 mm) rim board is added in this category for interpolation purposes only.

^F The 360 psi (2.48 N/mm²) stress is based upon the established compression perpendicular-to-grain design capacity of commodity floor sheathing products. The qualified compression perpendicular-to-grain capacity of a proprietary floor sheathing is permitted to be used in lieu of this value for specific applications that combine the rim board with the proprietary floor sheathing product.

TABLE 2 Deck Ledger Attachment Shear Capacity Limitations^{A,B}

Minimum Rim Board Thickness	1/2 in. (12.7 mm) Lag Screw with Washer		1/2 in. (12.7 mm) Bolt with Washers Each End		1/2 in. (12.7 mm) Bolt with Washers Each End and 1/2 in. (12.7 mm) Shimmed Airspace	
	Minimum	Maximum	Minimum	Maximum	Minimum	Maximum
1.0 in. (25 mm)	300 lbs. (1.34 kN)		300 lbs. (1.34 kN)		300 lbs. (1.34 kN)	
1.125 in. (29 mm)	350 lbs. (1.56 kN)	725 lbs. (3.23 kN)	350 lbs. (1.56 kN)	725 lbs. (3.23 kN)	350 lbs. (1.56 kN)	615 lbs. (2.74 kN)
1.25 in. (32 mm) and greater	350 lbs. (1.56 kN)		350 lbs. (1.56 kN)		350 lbs. (1.56 kN)	

^A Lag screws and bolts shall conform with ANSI/ASME Standard B18.2.1.

^B The fasteners are installed in the Y orientation and loaded in the X orientation per Fig. 2.

illustrated in Fig. 2. As specified in 7.1, the rim board vertical load capacity shall be determined based upon the lower of a direct test or calculation. Section 6.1.2 outlines the test used to directly establish the capacity. Section 6.1.3 describes testing needed to establish the X-orientation compression strength and stiffness of the material as required to complete the calculation. Section 6.1.4 describes an alternative weak-axis flatwise bending test that can be used to determine the X-orientation stiffness in lieu of an axial measurement.

6.1.1 *Conditioning*—The rim board material tested in 6.1.2, 6.1.3, and 6.1.4 shall be conditioned to equilibrium moisture content prior to testing under standardized atmospheric conditions of 68 ± 11°F (20 ± 6°C) and 65 ± 5 % relative humidity. Alternatively, material tested in accordance with 6.1.2 is permitted to be tested “as received” and without supplemental conditioning provided that the higher load factor described in 7.1.1 is used for design load development.

6.1.2 *Direct Test of Uniform Vertical Load Transfer:*

6.1.2.1 *Sample Sizes*—The sample sizes shall be sufficient to permit estimation of a population mean with 5 % precision and 75 % confidence. As shown in Fig. 3, the specimen length (*L* direction of Fig. 2) shall be a minimum of 12 in. (30 cm). For rectangular rim board products, a minimum of ten specimens of each depth and thickness shall be tested for each grade and

species. As an alternative, testing can be limited to the most critical depth and thickness that is assigned the same uniform vertical load transfer design value. For I-joists, a minimum of ten specimens of each depth, minimum web thickness, and web-to-flange joint configuration shall be tested for each type of flange material (sawn lumber or SCL, species and size), using the joist product with the minimum flange width and thickness. As an alternative, testing can be limited to the most critical combination that is assigned the same uniform vertical load transfer design value.

6.1.2.2 *Test Setup*—Fig. 3 illustrates the test setup. The rim board specimen shall be tested in uniform compression with the load applied parallel to the X-Axis of Fig. 2. Fixed steel platens shall be used. The deformation or crushing of the specimen for the full height shall be measured either using the cross-head movement of the test frame or by direct measurement with an external device.

6.1.2.3 *Initial Measurements*—Prior to each test, the specimen thickness (flange and web for an I-joist), depth, length, and weight shall be recorded.

6.1.2.4 *Loading*—A pre-load not to exceed 10 % of the anticipated failure load shall initially be applied and the deflection gauge zeroed. After the pre-load, the loading shall progress at a constant rate such that the average time to

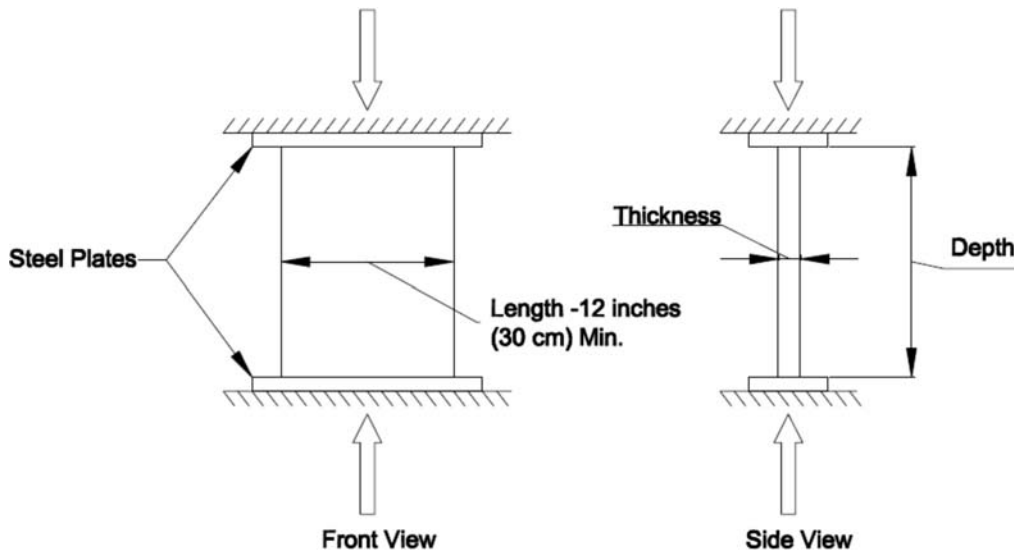

FIG. 3 Test Setup for Direct Measurement of Vertical Load Transfer

maximum load for the test series shall be at least 2 min. Total depth deformation versus load readings shall be taken continuously or at least every 0.01 in. (0.25 mm) until a 0.06-in. (1.5-mm) deformation limit is reached. Loading shall continue until failure occurs.

6.1.2.5 Recording—The member dimensions, failure mode, peak load, and load at 0.06-in. (1.5 mm) of deformation shall be recorded from each test. The loads shall be reported as both an absolute value and normalized by dividing the test result by the specimen length (L direction of Fig. 2).

6.1.3 X-Orientation Crushing Strength and Stiffness—The X-orientation crushing strength and stiffness of rectangular wood-based board products shall be tested in accordance with this section. Alternatively, oriented strand board, plywood, and the web materials for an I-joist rim board may use published strength and stiffness values in lieu of this testing.

6.1.3.1 Sample Sizes—The sample sizes shall be sufficient to estimate a fifth percentile tolerance limit with 75 % confidence. The calculated fifth percentile parametric tolerance limits (PTL) shall have a standard error no greater than 5 % of the PTL, when evaluated in accordance with 3.4.3.2 of Practice D2915.

6.1.3.2 Test Method—The short-column compression strength tests shall be undertaken in accordance with the principles of Test Methods D198 or D4761. The stiffness may be estimated using the deformation measurements outlined in D198 or, alternatively, the deformation measurements collected in 6.1.2 or 6.1.4 can be used to estimate stiffness if the crushing tests of this section are used only to measure the short-column compressive strength. The minimum cross-section permitted for the test shall be defined by the full product thickness paired with the corresponding width necessary to maintain at least 4.0 in.² (26 cm²) of tested surface area. The height shall be adjusted to provide an H/r ratio that is greater than 15 and less than 17, where H is the effective unsupported height and r is the least radius of gyration.

6.1.4 X-Orientation Stiffness—Alternative Weak-Axis Flatwise Bending Test: As an alternative to the axial modulus of elasticity measurement outlined in 6.1.2 or 6.1.3, the X-orientation modulus of elasticity may be estimated using a flatwise bending test about the L -axis as described below.

6.1.4.1 Sample Sizes—The sample sizes shall be sufficient to estimate a fifth percentile tolerance limit with 75 % confidence. The calculated fifth percentile parametric tolerance limits (PTL) shall have a standard error no greater than 5 % of the PTL, when evaluated in accordance with 3.4.3.2 of Practice D2915.

6.1.4.2 Test Method—These weak axis bending tests shall be undertaken in accordance with the principles of Test Methods D198. The depth of the test specimen shall be the actual product thickness in the Y direction, the width of the product shall be 3.5 in. (89 mm) in the L direction, and the length in the X -direction shall be sufficient to achieve a span-to-depth ratio of between 18 and 21. Loading shall be at third-points.

6.2 Lateral Load Transfer—The total lateral load transfer capacity of a rim board assembly shall be tested in accordance with this section.

6.2.1 Sample Sizes—The sample sizes shall permit estimation of a population mean with 5 % precision and 75 % confidence. For rectangular rim board products, a minimum of ten specimens of each depth and thickness shall be tested for each grade and species. As an alternative, testing can be limited to the most critical depth and thickness combination that is assigned the same lateral load transfer design value. For I-joists, a minimum of ten specimens of each depth, minimum web thickness and flange-to-web joint configuration shall be tested for each type of flange material (sawn lumber or SCL, species and size), using the joist product with the minimum flange width and thickness. As an alternative, testing can be limited to the most critical combination that is assigned the same lateral load transfer design value.

6.2.2 Rim Board Assembly Construction—A test assembly shall consist of rim board, sheathing, joists, and a sill plate, as shown in Fig. 4. The components and fastenings shall be representative of minimum details to be assigned the same design value in application. The joists shall be representative of the minimum I-joist that might be used with the rim board (lowest grade flange, thinnest web, thinnest flange, etc.). Dimensions for each component of the assembly shall meet the requirements given in Table 3. Joist spacing for the assembly shall be 24 in. (61 cm). The assembly shall be fabricated at least 12 h before mechanical testing. At a minimum, the nailing schedule for the test assembly shall follow the requirements given in Table 4. More intensive fastening schedules (that is, larger diameter nails or tighter fastener spacings, or both), alternative sheathing products and thicknesses, and alternative sill plate materials may be qualified when they are representative of lower bounds of the end-use application. The first and last fasteners between sheathing and rim board (edge nails), the sheathing and the joist, and the rim and the plate shall be not more than one half the nominal fastener spacing for each connection type.

6.2.3 Test Setup—Loads shall be applied through the sill plate while the sheathing reacts through full-width bearing, or vice versa. The line of load application shall be centered at the rim board or fixed platens shall be used to prevent out-of-plane rotation of the assembly under load. Vertical restraints, such as discrete rollers that do not interfere with the lateral resistance, or other similar devices may be used to provide vertical restraint for the assembly to avoid in-plane overturning. This restraint shall not interfere with the lateral deformation of the assembly in the direction parallel to loading and shall be placed within 12 in. (30 cm) of the loaded sheathing edge as depicted in Fig. 4. No in-plane or out-of-plane restraint shall be provided for the joists. Assembly deformations shall be measured based on the relative lateral displacements between the sill plate and sheathing along the entire length of the rim board. Vertical displacements caused by in-plane overturning forces are permitted to be isolated from the measurements of lateral deformations.

6.2.4 Loading—The loading rate shall not exceed 450 lbf (2.00 kN) per minute. The assembly shall be loaded to ultimate load or 0.4-in. (10-mm) lateral deformation, whichever comes first. No preload shall be applied. Load and deformation readings shall be taken at approximately equal load increments.