



Designation: ~~F384-06 (Reapproved 2011)~~ Designation: F384 – 12

Standard Specifications and Test Methods for Metallic Angled Orthopedic Fracture Fixation Devices¹

This standard is issued under the fixed designation F384; the number immediately following the designation indicates the year of original adoption or, in the case of revision, the year of last revision. A number in parentheses indicates the year of last reapproval. A superscript epsilon (ϵ) indicates an editorial change since the last revision or reapproval.

1. Scope

1.1 These specifications and test methods provide a comprehensive reference for angled devices used in the surgical internal fixation of the skeletal system. This standard establishes consistent methods to classify and define the geometric and performance characteristics of angled devices. This standard also presents a catalog of standard specifications that specify material, labeling, and handling requirements, and standard test methods for measuring performance related mechanical characteristics determined to be important to the *in vivo* performance of angled devices.

1.2 It is not the intention of this standard to define levels of performance or for case-specific clinical performance for angled devices, as insufficient knowledge is available to predict the consequences of their use in individual patients for specific activities of daily living. Furthermore, this standard does not describe or specify specific designs for angled devices used in the surgical internal fixation of the skeletal system.

1.3 This standard may not be appropriate for all types of angled devices. The user is cautioned to consider the appropriateness of this standard in view of a particular angled device and its potential application.

NOTE 1—This standard is not intended to address intramedullary hip screw nails or other angled devices without a sideplate.

1.4 This standard includes the following test methods used in determining the following angled device mechanical performance characteristics:

1.4.1 Standard test method for single cycle compression bend testing of metallic angled orthopedic fracture fixation devices (see Annex A1).

1.4.2 Standard test method for determining the bending fatigue properties of metallic angled orthopedic fracture fixation devices (see Annex A2).

1.5 The values stated in SI units are to be regarded as standard. No other units of measurement are included in this standard.

NOTE 2—There is currently no ISO standard that is either similar to equivalent to this standard.

2. Referenced Documents

2.1 *ASTM Standards*:²

E4 Practices for Force Verification of Testing Machines

E8 Test Methods for Tension Testing of Metallic Materials

E122 Practice for Calculating Sample Size to Estimate, With Specified Precision, the Average for a Characteristic of a Lot or Process

F67 Specification for Unalloyed Titanium, for Surgical Implant Applications (UNS R50250, UNS R50400, UNS R50550, UNS R50700)

F75 Specification for Cobalt-28 Chromium-6 Molybdenum Alloy Castings and Casting Alloy for Surgical Implants (UNS R30075)

F90 Specification for Wrought Cobalt-20Chromium-15Tungsten-10Nickel Alloy for Surgical Implant Applications (UNS R30605)

F136 Specification for Wrought Titanium-6Aluminum-4Vanadium ELI (Extra Low Interstitial) Alloy for Surgical Implant Applications (UNS R56401)

¹ These specifications and test methods are under the jurisdiction of ASTM Committee F04 on Medical and Surgical Materials and Devices and are the direct responsibility of Subcommittee F04.21 on Osteosynthesis.

Current edition approved June 1, 2011. Published July 2011. Originally approved in 1973. Last previous edition approved in 2006 as F384-06 ^{ε1}. DOI: 10.1520/F0384-06R11.

Current edition approved May 15, 2012. Published June 2012. Originally approved in 1973. Last previous edition approved in 2011 as F384 – 06 (2011). DOI: 10.1520/F0384-12.

² For referenced ASTM standards, visit the ASTM website, www.astm.org, or contact ASTM Customer Service at service@astm.org. For *Annual Book of ASTM Standards* volume information, refer to the standard's Document Summary page on the ASTM website.

- F138 Specification for Wrought 18Chromium-14Nickel-2.5Molybdenum Stainless Steel Bar and Wire for Surgical Implants (UNS S31673)
- F139 Specification for Wrought 18Chromium-14Nickel-2.5Molybdenum Stainless Steel Sheet and Strip for Surgical Implants (UNS S31673)
- F382 Specification and Test Method for Metallic Bone Plates ~~F543 Specification and Test Methods for Metallic Medical Bone Screws~~
- F565 Practice for Care and Handling of Orthopedic Implants and Instruments
- F620 Specification for Titanium Alloy Forgings for Surgical Implants in the Alpha Plus Beta Condition
- F621 Specification for Stainless Steel Forgings for Surgical Implants
- F983 Practice for Permanent Marking of Orthopaedic Implant Components
- F1295 Specification for Wrought Titanium-6Aluminum-7Niobium Alloy for Surgical Implant Applications (UNS R56700)
- F1314 Specification for Wrought Nitrogen Strengthened 22 Chromium 13 Nickel 5 Manganese 2.5 Molybdenum Stainless Steel Alloy Bar and Wire for Surgical Implants (UNS S20910)
- F1472 Specification for Wrought Titanium-6Aluminum-4Vanadium Alloy for Surgical Implant Applications (UNS R56400)
- F1713 Specification for Wrought Titanium-13Niobium-13Zirconium Alloy for Surgical Implant Applications (UNS R58130)
- 2.2 ISO Standards:³
 - ISO 5835 Implants for Surgery—Metal Bone Screws with Hexagonal Drive Connection—Spherical Under Surface of Head, Asymmetrical Thread
 - ISO 5836 Implants for Surgery—Metal Bone Plates—Holes Corresponding to Screws with Asymmetrical Thread and Spherical Under Surface
 - ISO 9268 Implants for Surgery—Metal Bone Screws with Conical Under-Surface of Head—Dimensions
 - ISO 9269 Implants for Surgery—Metal Bone Plates—Holes and Slots Corresponding to Screws with Conical Under-Surface
 - ISO 14602 Non-active Surgical Implants—Implants for Osteosynthesis—Particular Requirements

3. Terminology

3.1 Definitions—Geometric:

3.1 Definitions: Geometric

- 3.1.1 *angle, nangle (degree)*—defined at either the barrel/sideplate or blade/sideplate junction (see Fig. 1 and Fig. 2).
- 3.1.2 *angled device, ndevice*—a class of orthopedic devices—an orthopaedic device for the fixation of fractures in the metaphyseal areas of long bones that has a component aligned at an angle to the bone's long axis of the bone.
- 3.1.3 *barrel, nbarrel*—the portion of an angled device which captures the lag screw (see Fig. 1).
- 3.1.4 *barrel length, L_{BR}, nBR (mm)*—the distance from the free end of the barrel to the interior vertex of the barrel/sideplate junction (see Fig. 1).
- 3.1.5 *blade, nblade*—the portion of an angled device which transmits the off axis loading of the anatomical loading condition to the sideplate portion of the angled device (see Fig. 2).
- 3.1.6 *blade length, L_{BD}, nBD (mm)*—the distance from the free end of the blade to the interior vertex of the blade/sideplate junction (see Fig. 2).

³ Available from American National Standards Institute (ANSI), 25 W. 43rd St., 4th Floor, New York, NY 10036, <http://www.ansi.org>.

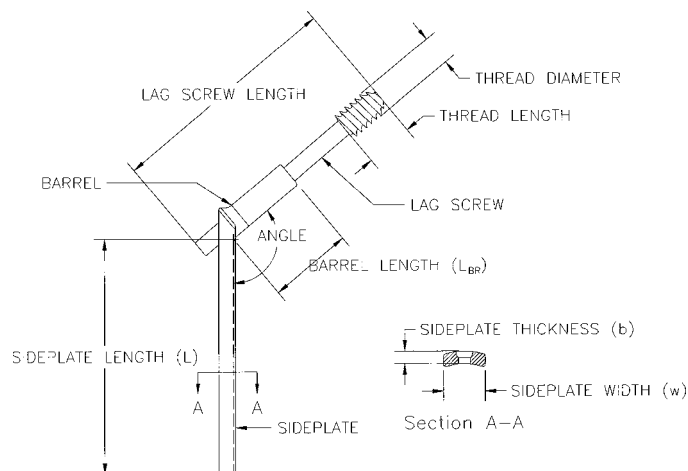

FIG. 1 Diagram Illustrating Compression Hip Screw Angled Devices

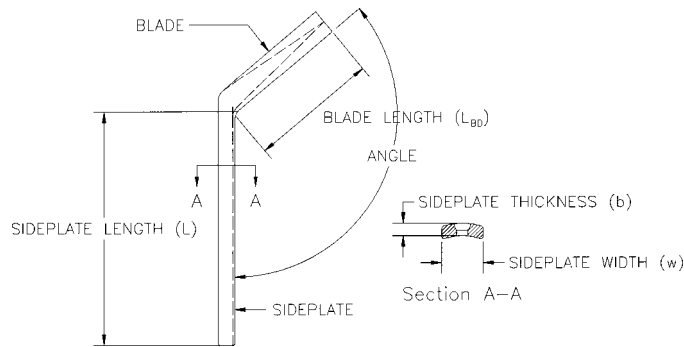

FIG. 2 Diagram Illustrating Blade Plate Angled Devices

3.1.7 *lag screw, nscrew*—that component of a compression hip screw angled device which is threaded into the metaphyseis and transmits the off axis load to the sideplate through the barrel (see Fig. 1).

3.1.8 *lag screw length, nlag screw length (mm)*—the straight line distance measured between the proximal and distal ends of the lag screw (see Fig. 1).

3.1.9 *sideplate, nsideplate*—that portion of the angle device generally aligned with the bone's long axis of the bone which attaches to the bone via bone screws (see Fig. 1 and Fig. 2).

3.1.10 *sideplate length, L, n*—the distance from the free end of the sideplate to the interior vertex of the barrel/sideplate junction, shown in sideplate length, L (mm)—the distance from the free end of the sideplate to the interior vertex of the barrel/sideplate junction or to the interior vertex of the blade/sideplate junction (see Fig. 1 and Fig. 2-).

3.1.11 *sideplate thickness, b, n*—the thickness of the sideplate as shown in sideplate thickness, b (mm)—the linear dimension of the sideplate measured parallel to the screw hole axis (see Fig. 1 and Fig. 2-). For a sideplate with a crescent section, the thickness is measured at the thickest point along the section.

3.1.12 *sideplate width, w, n*—the width of the sideplate as shown in sideplate width, w (mm)—the linear dimension of the sideplate measured perpendicular to both the length and thickness axes (see Fig. 1 and Fig. 2-).

3.1.13 *thread diameter, ndiameter (mm)*—the maximum outside/outer diameter of the lag screw threads (see Fig. 1).

3.1.14 *thread length, nthread length (mm)*—the straight line distance measured between the tip and thread runout positions of the screw (see Fig. 1).

3.2 Definitions—Mechanical/Structure :

3.2 Definitions: Mechanical/Structure:

3.2.1 *bending strength, nbending strength (N-m)*—of the sideplate, the bending moment necessary to produce a 0.2 % offset displacement in the sideplate when tested as described in Annex A1 of Specification and Test Methods Method F382.

3.2.2 *bending structural stiffness, El_e, ne(N-m²)*—of the sideplate, the sideplate's normalized effective bending stiffness of the sideplate that takes into consideration the effects of the test setup's setup configuration when tested according to the method described in Annex A1 of Specification and Test Methods F382.

3.2.3 *compression bending stiffness, (K), ncompression bending stiffness, (K) (N/m)*—of a device, the maximum slope of the linear elastic portion of the load versus displacement curve, when tested as described in Annex A1.

3.2.4 *compression bending strength, ncompression bending strength (N/m)*—of a device, the bending moment necessary to produce a 0.2 % offset displacement in the device when tested as described in Annex A1.

3.2.5 *fatigue strength at N cycles, ncycles*—an estimate of the cyclic forcing parameter; (for example, load, moment, torque, stress, etc., etc.) at a given load ratio, for which 50 % of the specimens within a given sample population would be expected to survive N loading cycles.

3.2.6 *fatigue life, N, nfatigue life, N*—the number of loading cycles of a specified character that a given specimen sustains before failure of a specified nature occurs.

4. Classification

4.1 Angled devices used in general orthopedic surgery represents a subset of bone plates. Angled devices are mainly used in the treatment of fractures in the metaphyseal areas of long bones. Angled devices can be categorized into general types according to the following classifications:

4.1.1 *Blade Plate*—an angled device where the component of the device that is oriented at an angle from the long axis of the bone is fixed relative to the sideplate; this component often is shaped like a blade to achieve fixation into the metaphyseis (see Fig. 2), and

4.1.2 *Compression Hip Screw*—an angled device where the component of the device which is oriented at an angle from the long axis of the bone is free to translate relative to the sideplate through a barrel; this component often achieves fixation into the metaphyseis through the use of deep threads (see Fig. 1).

5. Marking, Packaging, Labeling and Handling

- 5.1 Dimensions of angled devices should be designated by the standard definitions given in 3.1.
- 5.2 Angled devices shall be marked using a method specified in accordance with either Practice F983 or ISO 14602.
- 5.3 Markings on angled devices shall identify the manufacture or distributor and shall be ~~made~~situated away from the most highly stressed areas, where possible.
- 5.4 Packaging shall be adequate to protect the angled device during shipment.
- 5.5 Package labeling for angled devices shall include when possible the following information;:
- 5.5.1 Manufacturer and product ~~name~~,name;
- 5.5.2 Catalog ~~number~~,number;
- 5.5.3 Lot or serial ~~number~~,number;
- 5.5.4 Material and, where applicable, its associated ASTM specification designation ~~number~~,number;
- 5.5.5 Device angle, between the sideplate and the barrel (blade);
- 5.5.6 Barrel (blade) ~~length~~,length;
- 5.5.7 Number of screw ~~holes~~,holes;
- 5.5.8 Sideplate ~~width~~,width;
- 5.5.9 Sideplate ~~length~~,length;
- 5.5.10 Sideplate thickness;:
- 5.5.11 Screw hole ~~size~~,size; and
- 5.5.12 ASTM specification designation number.
- 5.6 Bone plates should be cared for and handled in accordance with Practice F565, as appropriate.

6. Materials

- 6.1 All angled devices made of materials which can be purchased to an ASTM specification shall meet those requirements given in the ASTM specification. Such specification include: F67, F75, F90, F139, ~~F543~~, F1295, F1314, F1472, and F1713.
- 6.2 Angled devices of forged Specification F136 shall meet the requirements of Specification F620.
- 6.3 Angled devices of forged Specification F138 shall meet the requirements of Specification F621.

7. General Requirements and Performance Considerations

7.1 *Geometric Considerations*—For angled devices that are intended to be used with bone screws that conform to ISO 5835 or ISO 9268, the screw holes shall correspond to the dimensions and tolerances of ISO 5836 or ISO 9269, respectively.

7.2 *Bending Properties*—Bending properties are a critical characteristic of angled devices for orthopedic applications since the plate provides the primary means of stabilizing the bone fragments. Additionally, the bending stiffness of the angled device may directly affect the rate and ability of healing.

7.2.1 The relevant compression bending properties (compression bending stiffness and compression bending strength) of the device shall be determined using Annex A1.

7.2.2 The relevant bending properties (bending stiffness, bending structural stiffness and bending strength) of the sideplate shall be determined using the Annex A1 of Specification and Test ~~Methods~~Method F382.

7.2.3 Determine the relevant angled device bending fatigue properties according to the methods described in Annex A2.

7.2.4 Determine the relevant side plate bending fatigue properties according to the methods described in Annex ~~A2~~A1 of Specification and Test ~~Methods~~Method F382.

8. Keywords

8.1 angled devices; bend testing; blade plate; compression hip screw; fatigue test; orthopedic medical devices; surgical devices; surgical implants

ANNEXES

(Mandatory Information)

A1. STANDARD TEST METHOD FOR SINGLE CYCLE COMPRESSION BEND TESTING OF METALLIC ANGLED ORTHOPEDIC FRACTURE FIXATION DEVICES

A1.1 Scope

A1.1.1 This test method describes methods for single cycle bend testing for determining intrinsic, structural properties of metallic angled orthopedic fracture fixation devices. The test method measures ~~the angled device's~~ compression bending stiffness and compression bending strength of the angled device.

A1.1.2 This test method is intended to provide a means to mechanically characterize different angled device designs. It is not the intention of this test method to define levels of performance for angled devices, as these characteristics are driven by patient-specific clinical requirements.

A1.1.3 This test method is designed to provide flexibility in the testing configuration so that a range of clinical failure modes for the angled fixation devices (for example, sideplate, lag screw, and barrel fractures) can be evaluated.

A1.1.4 The values stated in SI units are to be regarded as standard. No other units of measurement are included in this standard.

A1.1.5 *This standard does not purport to address all of the safety concerns, if any, associated with its use. It is the responsibility of the user of this standard to establish appropriate safety and health practices and determine the applicability of regulatory limitations prior to use.*

A1.2 Referenced Documents ²

A1.2.1 *ASTM Standards:*

E4 Practices for Load Verification of Testing Machines

E122 Practice for Choice of Sample Size to Estimate the Average Quality of a Lot or Process

A1.3 Terminology

A1.3.1 *Definitions:*

A1.3.1.1 *0.2 % offset displacement, q , n (mm)*—permanent deformation (~~mm~~) equal to 0.2 % of the lever arm length (see point B in Fig. A1.1).

A1.3.1.2 *compression bending stiffness, K , n (N/m)*—~~of an angled device~~, the maximum slope (N/m) of the linear elastic portion of the load versus displacement curve, when tested as described in A1.8. (See the slope of line ~~OmOm~~ in Fig. A1.1).

A1.3.1.3 *compression bending strength, n (N-m)*—~~of an angled device~~, the bending moment (N-m) necessary to produce a 0.2 % offset displacement in the angled device when tested as described in A1.8 (the bending moment corresponding to point P in Fig. A1.1). If the angled device fractures before the proof load is attained, the compression bending strength shall be defined as the bending moment at fracture.

A1.3.1.4 *fracture load, F_{max} , n (N)*—the applied load (N) at the time when the angled device fractures.

A1.3.1.5 *lever arm, L , n (mm)*—the instantaneous distance (~~mm~~) from the line of load application to the surface of the sideplate that is intended to be in contact with the bone at the most proximal location where the sideplate contacts the test fixture support (shown in Fig. A1.2); the initial unloaded angled device lever arm length shall be held constant for comparative tests.

A1.3.1.6 *permanent deformation, n (mm)*—the relative change (~~mm~~) in the position of the load application point's position point (in the direction of the applied load) remaining after the applied load has been removed.

A1.3.1.7 *potential critical stress concentrator, CSC, n* —any change in section modulus, material property, discontinuity, or other feature of an angled device design expected to cause a concentration of stress, that is located in a region of the angled device expected to be highly stressed under the normal anticipated loading conditions.

A1.3.1.8 *proof load, P , n (N)*—the applied load (N) at the intersection point of line BC with the load versus total displacement curve; curve (see Fig. A1.1).

A1.3.1.9 *proof point displacement, n* —the total displacement associated with the angled device's compression bending strength; strength of the angled device (see point A in Fig. A1.1).

A1.3.1.10 *total displacement, n (mm)*—the relative change (~~mm~~) in the position of the load application point's position point (in the direction of the applied load) when a specified load is applied.

A1.4 Summary of Test Method

A1.4.1 Angled devices are subjected to a single-cycle load introduced at the device's angled portion of the device. This results in the simultaneous application of compressive and cantilever bending stresses to the device. The device's compression bending stiffness and compression bending strength of the device are then derived from the ~~test~~ record generated during the test using relevant test configuration parameters.

A1.5 Significance and Use

A1.5.1 This compression bend test is used to determine values for the mechanical response of angled devices to a specific type of bending load. The information resulting from this test can give the surgeon some insight into the mechanical response of a given angled device.

A1.5.2 Since the loading on the angled device *in situ* will, in general, differ from the loading configuration used in this test method, the results obtained from this test method cannot be used directly to predict *in vivo* performance of the angled device being tested. Such mechanical property data can be used to conduct relative comparisons of different angled device designs.

A1.5.3 Since the test method provides flexibility to evaluate a variety of clinical failure modes, the user ~~must~~shall first determine which failure mode will be evaluated. Furthermore, the user should determine the relevance of the failure mode for the angled device being evaluated.

A1.5.4 The angled device's compression bending stiffness of the angled device, as defined in A1.3.1.2, is an indicator of the angled device's stiffness; stiffness of the angled device when subjected to a compression-bending load. This mechanical property is a comparative indicator of the stability that the user can achieve in the treatment of methaphyseal fractures with the angled device.

A1.5.5 The angled device's compression bending strength of the angled device, as defined in A1.3.1.3, identifies the bending moment that must be applied to the angled device in order to produce a specific amount of permanent deformation.

A1.5.6 This test method assumes that linear-elastic material behavior will be observed and, therefore, the test method is not applicable for the testing of materials that exhibit non-linear elastic behavior.

A1.6 Apparatus

A1.6.1 A typical test configuration is illustrated in Fig. ~~A1.2~~A1.1.

A1.6.2 The plate of the angled device being tested is rigidly attached to an anchor block that is fully constrained. Alternative test setups are allowed (for example, the device support is unconstrained with rollers as allowed by the previous version of this standard) as long as the following conditions are met.

A1.6.2.1 The angled device shall be loaded in such a manner as to satisfy the goals or requirements of A1.4.1, A1.5.1, and X2.1.

A1.6.2.2 If the angled device's support of the angled device is allowed to translate normal to the test machine's loading axis of the test machine in reaction to the applied load during the test, then the lever arm distance shall be monitored during the test. This information shall then be used to correct the load versus displacement curve ~~and the compression bending stiffness and strength values calculated in (A1.8.2.1:~~

~~A1.6.2.3 If the loading adapter's contact point is allowed to translate normal to the test machine's loading axis in reaction to the applied load during the test, then the lever arm distance shall be monitored during the test. This information shall then be used to correct the load versus displacement curve and the compression bending stiffness and strength values calculated in) and the compression bending stiffness and strength values calculated in A1.8.2.3 and A1.8.2.7, respectively.~~

A1.6.2.3 If the contact point of the loading adapter is allowed to translate normal to the loading axis of the test machine in reaction to the applied load during the test, then the lever arm distance shall be monitored during the test. This information shall then be used to correct the load versus displacement curve (A1.8.2.1) and the compression bending stiffness and strength values calculated in A1.8.2.3 and A1.8.2.7, respectively.

A1.6.3 The applied load should act only parallel to the sideplate's long axis of the sideplate. Apply the load at a point that will produce a lever arm length that is equivalent to 80 % of either the blade length or the longest screw. Equivalent lever arm lengths must be used for comparative tests. Deviations to this requirement shall be noted and justified in the final report. Additionally, the application of off axis loads to the load cell must be avoided since, depending on their magnitude, they can confound the determination of the device's actual loading condition of the device.

A1.6.4 The test fixture should, in general, support the angled device in such a way as to generate the failure being evaluated (sideplate, lag screw, or barrel fracture). A typical configuration that can be used to evaluate the angled device's sideplate failure characteristics of the angled device is illustrated in Fig. A1.2.

A1.6.5 The device being tested should be suitably anchored to the support fixture. The intent of the test method is to evaluate the angled device and not the sideplate anchors.

A1.6.6 Displacement shall be measured as the displacement of the load application point parallel to the sideplate's long axis of the sideplate.

A1.6.7 Alternative loading configurations are allowed **(1)**⁴ but must be noted and fully described in the final report.

A1.6.8 Machines used for the bending test shall conform to the requirements of Practice E4.

A1.6.9 The test machine and fixtures (test system) should be sufficiently stiff that their deformation under the load is negligible relative to that of the angled device being tested. The test system's machine compliance of the test system (combined test machine and fixture compliance) should be measured and reported. Typically, the test system's machine compliance of the test system should be less than 1 % of the compliance of the tested angled device's compliance. device.

A1.7 Sampling

A1.7.1 Determine sample size using the methods outlined in Practice E122.

A1.7.2 In those circumstances when there is insufficient information to utilize the guidance of Practice E122, the sample size shall be no less than three.

A1.7.3 Angled devices of different lengths but nominally identical cross-sections, and made of the same material, may be used to constitute a sample.

A1.7.4 Only unused and untested angled devices are shall be used allowed for the comparative tests.

A1.8 Procedure

A1.8.1 Apply loads of increasing magnitude to the angled device at a recommended test control rate of 10 mm/min, and generate a load versus displacement diagram either auto-graphically or from numeric data acquired during the test. Displacement-controlled testing is strongly preferred over load-controlled testing. The measured deformation behavior past the yield point can be different for load-controlled testing due to non-linear displacement rates.

⁴Peterson, R. R., Lynch, G. E., Brasher, T. W., "Cyclic Cantilever Fatigue Testing of Compression Hip Screw Plates," *ASTM STP 1217, Clinical and Laboratory Performance of Bone Plates*, pp. 72-81, 1994, American Society of Testing and Materials, West Conshohocken, PA 19428.

⁴ The boldface numbers in parentheses refer to a list of references at the end of this standard.