



Standard Specification for Pole Vault Landing Systems¹

This standard is issued under the fixed designation F1162/F1162M; the number immediately following the designation indicates the year of original adoption or, in the case of revision, the year of last revision. A number in parentheses indicates the year of last reapproval. A superscript epsilon (ϵ) indicates an editorial change since the last revision or reapproval.

1. Scope

1.1 This specification covers minimum requirements of size, physical characteristics of materials, standard testing procedures, labeling and identification of pole vault landing systems.

1.2 *Units*—The values stated in either SI units or inch-pound units are to be regarded separately as standard. The values stated in each system may not be exact equivalents; therefore, each system shall be used independently of the other. Combining values from the two systems may result in non-conformance with the standard.

1.3 *This standard does not purport to address all of the safety concerns, if any, associated with its use. It is the responsibility of the user of this standard to establish appropriate safety and health practices and determine the applicability of regulatory limitations prior to use.*

2. Referenced Documents

2.1 *ASTM Standards*:²

F1292 Specification for Impact Attenuation of Surfacing Materials Within the Use Zone of Playground Equipment

3. Terminology

3.1 *Definitions*:

3.1.1 *base unit sections, n*—those components of a pole vault landing system where the pole vaulter intends to land.

3.1.1.1 *Discussion*—The base unit sections provide the majority of the padding behind the planting box. In most pole vault landing systems, they are several large rectangular sections that compose the majority of this portion of the landing system. (See Fig. 1.)

3.1.2 *common top cover, n*—the continuous covering over the top surfaces of all parts of the primary landing system.

3.1.2.1 *Discussion*—It may function both as padding and as a binder to help hold the base units and front bun sections in place during use. (See Fig. 1.)

3.1.3 *front bun sections, n*—those components of the primary landing system that pad the areas between the standard bases and around the pole vault box. (See Fig. 1.)

3.1.4 *pole vault box, n*—a trough at the end of the pole vault runway. A vaulter slides the end of the pole into the pole vault box.

3.1.4.1 *Discussion*—The pole vault box stops the forward motion of the end of the pole while allowing the pole to rotate about its end as the vaulter leaves the ground and completes a vault.

3.1.5 *pole vault landing system, n*—a device used to decelerate a free-falling pole vaulter.

3.1.6 *preferred landing zone, n*—a painted or sewn contrasting rectangle on the common top pad, 2.44 m [8 ft] deep and 3.05 m [10 ft] wide, beginning 1.07 m [42 in.] behind the reference point. (See Fig. 1.)

3.1.7 *primary landing system, n*—that portion of a pole vault landing system that consists of several components held together to form a continuous landing surface.

3.1.7.1 *Discussion*—The base unit sections, front bun sections, and common top cover are all components of the primary landing system.

3.1.8 *reference point, n*—the point defined by the intersections of the horizontal plane at the level of the runway, the vertical plane passing through the top edge of the back of the pole vault box, and the vertical plane passing through the centerline of the runway.

3.1.9 *standard base pads, n*—the pads covering the bases of the pole vault standards and the surfaces between the bases of the pole vault standards and primary landing system.

4. Minimum Overall Dimensions of Pole Vault Landing Systems

4.1 The minimum pole vault landing system dimensions stated within this document are based upon the investigation of catastrophic pole vaulting accidents.

4.2 The minimum overall dimensions for the primary landing system are 6.00 m [19 ft, 8 in.] wide by 6.15 m [20 ft, 2 in.] long from the front edge of the front buns to the rear-most edge

¹ This specification is under the jurisdiction of ASTM Committee F08 on Sports Equipment and Facilities and is the direct responsibility of Subcommittee F08.67 on Pole Vault.

Current edition approved May 1, 2012. Published June 2012. Originally approved in 1988. Last previous edition approved in 2002 as E1162 – 02 which was withdrawn April 2011 and reinstated in May 2012. DOI: 10.1520/F1162_F1162M-12.

² For referenced ASTM standards, visit the ASTM website, www.astm.org, or contact ASTM Customer Service at service@astm.org. For *Annual Book of ASTM Standards* volume information, refer to the standard's Document Summary page on the ASTM website.

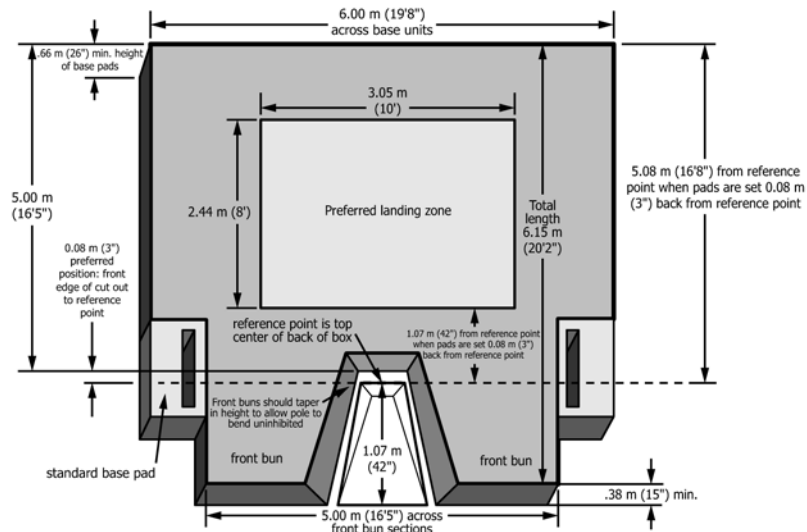

FIG. 1 Pole Vault Landing System Minimum Dimensions and Preferred Landing Zone

of the landing system by 0.66 m [26 in.] high. (See Fig. 1.) If the front edge of the pole vault box cutout of the primary landing system is set 0.08 m [3 in.] behind the reference point, the minimum length of the landing system is 5.00 m [16 ft, 5 in.] from the front edge of the cutout of the landing system.

4.3 The minimum width across all the base unit sections is 6.00 m [19 ft, 8 in.]. This minimum width extends from the rearmost edge of the landing system to a maximum of 1.73 m [5 ft, 8 in.] behind the reference point.

4.4 The minimum width across all of the front bun sections is 5.00 m [16 ft, 5 in.]. The front edge of the front bun sections is at least 1.07 m [42 in.] in front of the reference point. The minimum total length of the pole vault box cutout is thus 1.14 m [45 in.]. The maximum width of the pole vault box cutout (the maximum distance between the bases of the front buns bordering either side of the pole vault box) measured at the base of the front buns shall be 0.91 m [36 in.].

4.5 The height of the front buns should taper downward towards the pole vault box so that the vaulting pole is allowed to bend and rotate undisturbed by contact with the front buns. Excluding this tapered portion of the front buns adjacent to the pole vault box cutout, the height of the front buns may taper from 0.66 m [26 in.] at the rear to a minimum height of 0.38 m [15 in.]. (See Fig. 1.)

4.6 Standard base pads shall be at least 0.38 m [15 in.] high and should match but not exceed the height of the adjacent primary landing system.

4.7 Standard base pads shall minimally extend laterally from the outside edges of the front bun sections to a line 3.00 m [9 ft, 10 in.] from the reference point.

4.8 Standard base pads shall extend rearward to the front edge of the lateral base unit sections.

4.9 Standard base pads shall extend forward at least as far as the front most projection of the pole vault standard bases. If the pole vault landing system includes front buns whose most forward section includes parts that project laterally in front of

the pole vault standard bases, the standard base pads shall extend forward to the rear most edge of this lateral projection of the front buns.

4.10 The openings in the standard base pads for the uprights shall not be more than 0.20 m [8 in.] wide. Standard base pads shall cover the entire area of the standard bases with the exception of the opening for the uprights. The standard base pads must allow for movement of the uprights as specified in the rules.

4.11 The preferred landing zone should be identified on the top cover of the pole vault landing system by painting or sewing a contrasting rectangle on the common top cover, 2.44 m [8 ft] deep and 3.05 m [10 ft] wide, beginning 1.07 m [42 in.] behind the reference point. This rectangle is intended as a reference for vaulters and coaches. (See Fig. 1.)

5. Performance Requirements

5.1 The average peak acceleration calculated from the last two of a series of three impact tests for each impact test location within the boundaries of the preferred landing zone of the primary landing system shall not exceed 25 g when impact tested in accordance with Section 9.

5.2 The average peak acceleration calculated from the last two of a series of three impact tests for each impact test location on the primary landing system but outside the boundaries of the preferred landing zone of the pole vault landing system shall not exceed 38 g when impact tested in accordance with Section 9.

5.3 The average peak acceleration calculated from the last two of a series of three impact tests for each impact test location on the standard base pads shall not exceed 38 g when impact tested in accordance with Section 9.

6. Significance and Use

6.1 The dynamic data obtained with the procedures given in this specification measure the cushioning properties of the pole vault landing systems tested.