



Standard Test Method for Impact Resistance of Poly(Vinyl Chloride) (PVC) Rigid Profiles by Means of a Falling Weight¹

This standard is issued under the fixed designation D4495; the number immediately following the designation indicates the year of original adoption or, in the case of revision, the year of last revision. A number in parentheses indicates the year of last reapproval. A superscript epsilon (ϵ) indicates an editorial change since the last revision or reapproval.

1. Scope*

1.1 This test method covers the determination of the energy required to crack or break rigid poly(vinyl chloride) (PVC) profile under specified conditions of impact by means of a falling weight.

1.2 This test method is able to be used either by itself or in conjunction with other methods ~~or~~ for measuring PVC product toughness.

1.3 Because of the wide variety of profile sizes and shapes and the wide variety of manufacturing procedures and field abuse, this test method does not correlate universally with all types of abuse. Therefore, correlations must be established as needed.

~~1.4~~ 1.4 The text of this standard references notes and footnotes which provide explanatory material. These notes and footnotes (excluding those in tables and figures) shall not be considered as requirements of this standard.

1.5 The values stated in inch-pound units are to be regarded as the standard.

~~NOTE 1—There is no equivalent or similar ISO standard.~~ 1—There is no known ISO equivalent to this standard.

1.6 *This standard does not purport to address all of the safety concerns, if any, associated with its use. It is the responsibility of the user of this standard to establish appropriate safety and health practices and determine the applicability of regulatory limitations prior to use.*

2. Referenced Documents

2.1 *ASTM Standards:*²

D618 Practice for Conditioning Plastics for Testing

D883 Terminology Relating to Plastics

E178 Practice for Dealing With Outlying Observations

3. Terminology

3.1 *Definitions*—Definitions are in accordance with Terminology D883, unless otherwise indicated.

3.2 *Definitions of Terms Specific to This Standard:*

3.2.1 *failure*—the presence of a brittle failure readily visible by the naked eye, including a sharp crack, split, or shatter in any part of the profile as a result of the impact of the falling weight. Failure does not include ductile tears (where the surfaces at the tip of the crack have a greater than 0° angle), or ductile breaks (hinged breaks where the cracked part remains joined to the unbroken part throughout the length of the cracked part or section), (Fig. 1).

3.2.2 *mean failure height*—the height from which the falling weight will cause 50 % of the specimens to fail.

3.2.3 *mean failure energy*—energy required to produce 50 % failures. The product of the weight and mean failure height.

3.2.4 *outlier*—an observation that appears to deviate markedly from other members of the sample in which it occurs.

4. Summary of Test Method

4.1 The profile is cut into lengths of at least 6 in. The test method establishes the height from which a standard falling weight will cause 50 % of the specimens to fail.

5. Significance and Use

5.1 The impact strength of PVC profiles relates to suitability for service and to quality of processing. Impact tests are used for quality-control purposes and as an indication that products can withstand handling during assembling, installation, or in service.

¹ This test method is under the jurisdiction of ASTM Committee D20 on Plastics and is the direct responsibility of Subcommittee D20.24 on Plastic Building Products. Current edition approved March 1, 2005; 2012. Published March 2005; June 2012. Originally approved in 1985. Last previous edition approved in 2000 as D4495 – 00(2005). DOI: 10.1520/D4495-00R05.10.1520/D4495-12.

² For referenced ASTM standards, visit the ASTM website, www.astm.org, or contact ASTM Customer Service at service@astm.org. For *Annual Book of ASTM Standards* volume information, refer to the standard's Document Summary page on the ASTM website.

*A Summary of Changes section appears at the end of this standard.

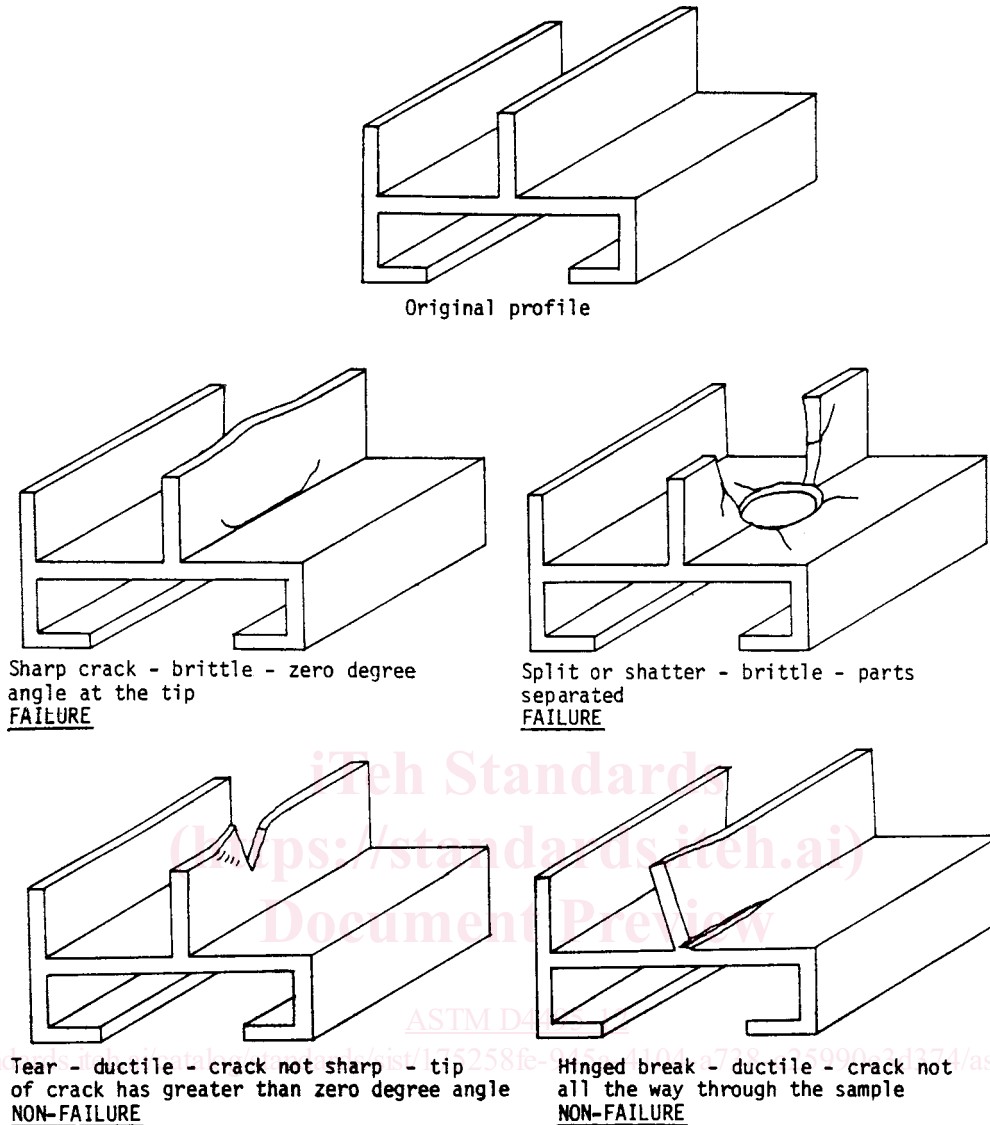

FIG. 1 Types of Breaks

- 5.2 Results obtained by use of this test method can be used in two ways:
 - 5.2.1 As the basis for establishing impact-test requirements in product standards, and
 - 5.2.2 To measure the effect of changes in materials or processing.

6. Apparatus

6.1 *General*—One type of impact tester is illustrated in Fig. 2.

6.2 *Falling Weight*, shall be cylindrical and 2 ½ in. in diameter, with a flat-bottom surface that strikes the test specimen.

NOTE 2—It is suggested that the striking portion of the weight be made of scratch-resistant steel to reduce damage to the striking surface. Badly scarred surfaces may affect test results.

6.2.1 The mass of the falling weight shall be 10 ± 0.5 lb.

6.3 *Drop Tube*, shall be of sufficient length (approximately 12 ft (4 m)) to provide for a fall of at least 10 ft (3 m) and shall be mounted so that the lengthwise direction is vertical, as measured with a plumb bob or a spirit level at least 2 ft (600 mm) in length.

6.3.1 Care must be taken to ensure that the weight falls freely; it must not “chatter” down the tube.

NOTE 3—No particular material for the drop tube is specified. However, a cold-drawn seamless steel tubing with an inside diameter of 2 5/8 to 2 3/4 in. (67 to 70 mm) has been found to be satisfactory. It may also be necessary to provide a protective barrier around the specimen, particularly for larger sizes of profile, to protect the operator from flying broken pieces.

NOTE 4—The dropped weight may not fall freely if the clearance between the weight and tube is too large or too small, or if it is restrained by a partial vacuum above the weight, such as can be caused by the hold and release device.

6.3.2 Means shall be provided to hold the weight to be dropped at steps of 2 in. (50 mm) for a distance of 2 to 10 ft (600 mm

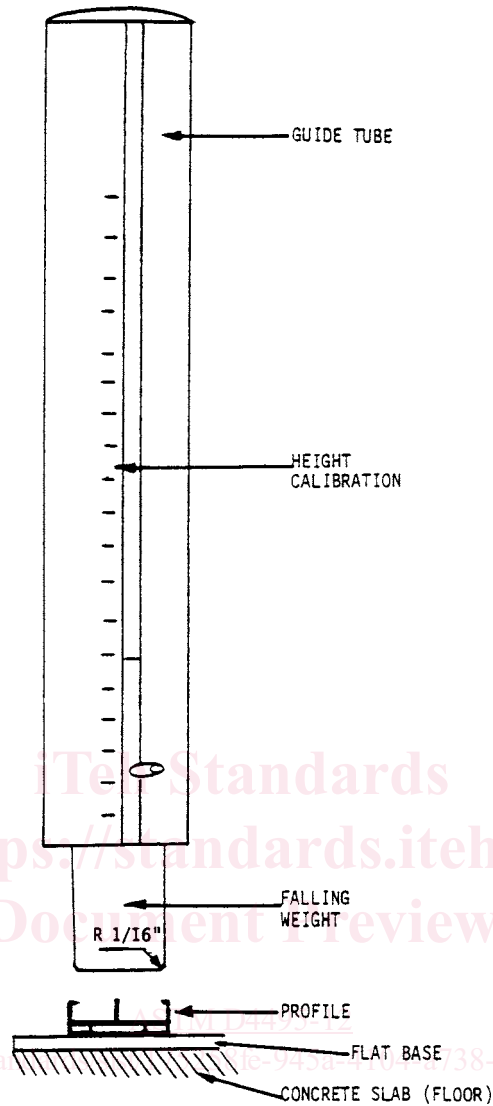

FIG. 2 Testing Apparatus

to 3 m) above the flat-plate holder, to release the weight in a reproducible manner, and to allow the weight to fall freely.

6.4 *Specimen Holder*—The flat plate shall be used as a specimen holder.

6.4.1 The rigid steel flat-plate holder shall consist of a plate approximately 8 by 12 by 1 in. (200 by 300 by 25 mm). The specimen holder shall be fastened to a concrete slab (floor). Means shall be provided to center the specimens under the drop tube.

7. Test Specimens

7.1 The profile shall be not less than 6 in. (150 mm) in length.

7.2 When the approximate mean-failure height for a given sample is known, 20 specimens usually yield sufficiently precise results. If the mean failure height is not able to be approximated, six or more specimens shall be used to determine the appropriate starting point of the test.

NOTE 5—As few as five specimens often yield sufficiently reliable estimates of the mean failure height. However, in such cases, the estimated standard deviation will be relatively large.³

8. Conditioning

8.1 Unless otherwise specified, condition the test specimens at $73.4 \pm 3.6^\circ\text{F}$ ($23 \pm 2^\circ\text{C}$) and $50 \pm 5\%$ to 10% relative humidity for not less than 24 h prior to test in accordance with Procedure A of Methods D618. In cases of disagreement, the tolerance shall be $\pm 1.8^\circ\text{F}$ ($\pm 1^\circ\text{C}$) and $\pm 2\%$ to $\pm 5\%$ relative humidity.

³ Brownless, K. A., Hodges, J. L., Jr., and Rosenblatt, Murray, "The Up-and-Down Method With Small Samples", American Statistical Association Journal, *JSTNA*, Vol 48, 1953, pp. 262-277.