**Mobile elevating work platforms —
Design, calculations, safety
requirements and test methods
relative to special features —**

Part 2:

**MEWPs with non-conductive
(insulating) components**

iTeh STANDARD PREVIEW
(standards.iteh.ai)

*Plates-formes élévatrices mobiles de personnel — Conception,
calculs, exigences de sécurité et méthodes d'essai concernant les
caractéristiques spéciales —*

<https://standards.iteh.ai/catalog/standards/si/4024-9648-0120b365b443/iso-16653-2-2021>

Partie 2: PEMP avec composants non conducteurs (isolants)



iTeh STANDARD PREVIEW (standards.iteh.ai)

ISO 16653-2:2021

<https://standards.iteh.ai/catalog/standards/sist/78f239c6-2c2f-4024-9648-0b20b3f6b443/iso-16653-2-2021>



COPYRIGHT PROTECTED DOCUMENT

© ISO 2021

All rights reserved. Unless otherwise specified, or required in the context of its implementation, no part of this publication may be reproduced or utilized otherwise in any form or by any means, electronic or mechanical, including photocopying, or posting on the internet or an intranet, without prior written permission. Permission can be requested from either ISO at the address below or ISO's member body in the country of the requester.

ISO copyright office
CP 401 • Ch. de Blandonnet 8
CH-1214 Vernier, Geneva
Phone: +41 22 749 01 11
Email: copyright@iso.org
Website: www.iso.org

Published in Switzerland

Contents

	Page
Foreword	v
Introduction	vi
1 Scope	1
2 Normative references	1
3 Terms and definitions	2
4 Safety requirements and/or protective/risk reduction measures	2
4.1 General.....	2
4.2 Structural requirements.....	2
4.3 Hydraulic liquid.....	3
4.4 Non-conductive hydraulic and pneumatic hoses.....	3
4.5 Work platforms.....	3
4.5.1 Work platform materials.....	3
4.5.2 Work platforms designed for use without an insulating liner.....	3
4.5.3 Work platforms designed for use with an insulating liner.....	3
4.5.4 Non-conductive (insulating) work platforms.....	3
4.6 Electrical requirements.....	3
4.6.1 Non-conductive (insulating) components.....	3
4.6.2 Hydraulic and pneumatic hose.....	3
4.6.3 Lower test electrode system for MEWPs with non-conductive (insulating) components.....	3
4.6.4 Chassis insulating system.....	4
5 Verification of the safety requirements and/or protective/risk reduction measures	4
5.1 Examinations and tests.....	4
5.2 Design check.....	4
5.3 Manufacturing check.....	5
5.4 Tests.....	5
5.4.1 Dielectric tests.....	5
5.4.2 Test criteria for MEWPs with a chassis insulating system.....	6
5.5 Electrical tests.....	6
5.5.1 General.....	6
5.5.2 Test criteria for MEWPs with non-conductive (insulating) boom including lower test electrode system.....	6
5.5.3 Test criteria for MEWPs having non-conductive (insulating) components without lower test electrode system.....	7
5.5.4 Test criteria for aerial ladder and vertical tower MEWPs with non-conductive (insulating) components (sections).....	10
5.5.5 Test criteria for chassis insulating systems.....	11
5.5.6 Test criteria for insulating platform liners.....	12
5.5.7 Verification of tests in 5.5.....	12
5.6 Initial inspection and test.....	12
6 Information for use	12
6.1 General.....	12
6.2 Operator's manual.....	13
6.3 Markings.....	13
6.3.1 General.....	13
6.3.2 Responsible entity's plate.....	13
6.3.3 Work platform.....	13
7 Safety principles, inspection, maintenance, and operation	14
7.1 General.....	14
7.2 Maintenance.....	14
7.2.1 Pre-start inspection.....	14
7.2.2 Annual mechanical inspection/testing.....	14

7.2.3	Annual confirmation electrical test.....	15
7.2.4	Electrical tests.....	15
7.2.5	Electrical test equipment.....	18
7.2.6	Electrical certification.....	18
7.3	Modifications or alterations.....	18
Annex A (informative) List of significant hazards.....		19
Bibliography.....		20

iTeh STANDARD PREVIEW
(standards.iteh.ai)

[ISO 16653-2:2021](https://standards.iteh.ai/catalog/standards/sist/78f239c6-2c2f-4024-9648-0b20b3f6b443/iso-16653-2-2021)

<https://standards.iteh.ai/catalog/standards/sist/78f239c6-2c2f-4024-9648-0b20b3f6b443/iso-16653-2-2021>

Foreword

ISO (the International Organization for Standardization) is a worldwide federation of national standards bodies (ISO member bodies). The work of preparing International Standards is normally carried out through ISO technical committees. Each member body interested in a subject for which a technical committee has been established has the right to be represented on that committee. International organizations, governmental and non-governmental, in liaison with ISO, also take part in the work. ISO collaborates closely with the International Electrotechnical Commission (IEC) on all matters of electrotechnical standardization.

The procedures used to develop this document and those intended for its further maintenance are described in the ISO/IEC Directives, Part 1. In particular, the different approval criteria needed for the different types of ISO documents should be noted. This document was drafted in accordance with the editorial rules of the ISO/IEC Directives, Part 2 (see www.iso.org/directives).

Attention is drawn to the possibility that some of the elements of this document may be the subject of patent rights. ISO shall not be held responsible for identifying any or all such patent rights. Details of any patent rights identified during the development of the document will be in the Introduction and/or on the ISO list of patent declarations received (see www.iso.org/patents).

Any trade name used in this document is information given for the convenience of users and does not constitute an endorsement.

For an explanation of the voluntary nature of standards, the meaning of ISO specific terms and expressions related to conformity assessment, as well as information about ISO's adherence to the World Trade Organization (WTO) principles in the Technical Barriers to Trade (TBT), see www.iso.org/iso/foreword.html (standards.iteh.ai)

This document was prepared by Technical Committee ISO/TC 214, *Elevating work platforms*.

This second edition ~~is a technical revision of the first edition (ISO 16653-2:2009), which has been technically revised.~~ and replaces the first edition (ISO 16653-2:2009), which has been technically revised.

The main changes compared to the previous edition are as follows:

- the limitation of applicability to 46 kV and below has been clarified in the Scope;
- the normative references have been updated;
- the hazard list has been moved to [Annex A](#);
- in [Clause 4](#), the bursting safety factors have been aligned with ISO 16368;
- in [Clause 4](#), the requirements for vacuum flashover have been removed and the work platform requirements have been clarified and re-organized;
- in [Clause 5](#), general requirements for examination and test have been added;
- [Table 1](#) and [Table 2](#) have been updated.

A list of all parts in the ISO 16653 series can be found on the ISO website.

Any feedback or questions on this document should be directed to the user's national standards body. A complete listing of these bodies can be found at www.iso.org/members.html.

Introduction

The object of this document is to define rules for safeguarding persons and objects against the risk of accident associated with the operation of special-application mobile elevating work platforms (MEWPs).

This document does not repeat all the general technical rules applicable to every electrical, mechanical or structural component.

The safety requirements of this document have been drawn up on the basis that MEWPs are periodically maintained according to the manufacturer's instructions, working conditions, frequency of use and applicable regulations.

It is assumed that MEWPs will be checked for proper function daily before start of work and that the MEWP will not be put into operation unless all required controls and safety devices are available and in working order. If a MEWP is seldom used, the checks may be made before start of work.

Where, for clarity, an example of a safety measure is given in the text, the example is intended as a possible solution. Any other safety measure solution leading to an equivalent level of safety is permissible.

iTeh STANDARD PREVIEW (standards.iteh.ai)

ISO 16653-2:2021

<https://standards.iteh.ai/catalog/standards/sist/78f239c6-2c2f-4024-9648-0b20b3f6b443/iso-16653-2-2021>

Mobile elevating work platforms — Design, calculations, safety requirements and test methods relative to special features —

Part 2: MEWPs with non-conductive (insulating) components

1 Scope

This document specifies the design, calculations, safety requirements and test methods for mobile elevating work platforms (MEWPs) with non-conductive (insulating) components. It is intended to be used in conjunction with ISO 16368.

It is applicable to all types and sizes of MEWPs with non-conductive (insulating) components, including dielectric components designed and tested to meet the specific electrical properties consistent with the manufacturer's identification plate. This equipment is intended to move persons, tools and equipment to working positions where they can carry out work from a work platform located above a non-conductive (insulating) boom section.

This document covers structural design calculations and the application of stability criteria, construction, safety examinations and tests done before MEWPs with non-conductive (insulating) components are first put into service. [Annex A](#) identifies the hazards arising from the use of MEWPs with non-conductive (insulating) components and describes methods for the elimination or reduction of these hazards. <https://standards.iteh.ai/catalog/standards/sist/78f239c6-2c2f-4024-9648-0b20b3f6b443/iso-16653-2-2021>

MEWPs covered in this document are not intended to have any of their components make contact with live parts of electrical installations. The electrical properties of a MEWP's non-conducting (insulating) components can provide electrical protection in case of inadvertent contact above the non-conductive boom component at the platform end. If a MEWP is equipped with a chassis insulating system, it can provide electrical protection for ground personnel in case of inadvertent contact above that system.

This document is not applicable to MEWPs designed for or capable of operating in live working conditions (see IEC 61057). The electrical insulation level is limited to voltages experienced in electrical distribution systems 46 kV and below.

2 Normative references

The following documents are referred to in the text in such a way that some or all of their content constitutes requirements of this document. For dated references, only the edition cited applies. For undated references, the latest edition of the referenced document (including any amendments) applies.

ISO 12100, *Safety of machinery — General principles for design — Risk assessment and risk reduction*

ISO 16368:2010, *Mobile elevating work platforms — Design, calculations, safety requirements and test methods*

ISO 18893:2014, *Mobile elevating work platforms — Safety principles, inspection, maintenance and operation*

IEC 61057, *Live working — Insulating aerial devices for mounting on a chassis*

3 Terms and definitions

For the purposes of this document, the terms and definitions given in ISO 16368:2010 and the following apply.

ISO and IEC maintain terminology databases for use in standardization at the following addresses:

- ISO Online browsing platform: available at <https://www.iso.org/obp>
- IEC Electropedia: available at <http://www.electropedia.org/>

3.1 chassis insulating system
system of non-conductive (insulating) components installed between the chassis and the structure supporting the upper non-conductive (insulating) boom

Note 1 to entry: Such a system, when properly maintained, can provide insulation of the chassis, should the portion of the MEWP between the upper non-conductive (insulating) boom and this system inadvertently contact an energized conductor or other apparatus.

3.2 electrical insulation level
level of phase-to-earth (ground) electrical insulation offered by the non-conductive (insulating) components of the upper boom and expressed by the maximum nominal voltage of an electrical installation (line or equipment) in case of inadvertent contact with this installation above the non-conductive (insulating) components at the platform end of the MEWP

Note 1 to entry: The electrical insulation level is established by the MEWP's responsible entity.

Note 2 to entry: The electrical insulation level is limited to voltages experienced in electrical distribution systems (46 kV and below).

3.3 insulating liner
insert made of non-conductive (insulating) material and designed to fit inside the work platform

3.4 non-destructive examination
examination by various means of devices or their components without alteration of the original components, so that they can function as before the testing

Note 1 to entry: These include acoustic emissions (AE), magnetic particle (MT), liquid penetrant (PT), ultrasonic (UT), radiography (RT), dielectric (DT), and visual (VT).

4 Safety requirements and/or protective/risk reduction measures

4.1 General

4.1.1 The machine shall be designed according to the principles of ISO 12100 for relevant but not significant hazards that are not dealt with by this document.

4.1.2 Except where otherwise specified in this document, the machine shall be in accordance with ISO 16368:2010.

NOTE National or local requirements can apply, which could be more stringent.

4.2 Structural requirements

Structural requirements shall be in accordance with ISO 16368:2010.

4.3 Hydraulic liquid

Hydraulic liquid (usually oil or similar fluid) shall meet the requirements of the responsible entity and the insulating requirements of the MEWP.

4.4 Non-conductive hydraulic and pneumatic hoses

Non-conductive hydraulic hoses and pneumatic hoses shall meet the requirements of IEC 61057.

4.5 Work platforms

4.5.1 Work platform materials

The work platform shall be constructed of non-conductive materials that does not sustain a flame after an ignition source has been removed.

NOTE UL 94 – H-B or IEC 60695-11-10 can be used for guidance.

4.5.2 Work platforms designed for use without an insulating liner

A work platform designed for use without an insulating liner shall meet the requirements of ISO 16368:2010, 4.6.16.

4.5.3 Work platforms designed for use with an insulating liner

A work platform designed for use with an insulating liner shall be identified as non-insulating. The insulating liner shall be constructed from non-conductive materials and tested in accordance with IEC 61057. The insulating liner shall be supported by the inside bottom surface of the work platform. A work platform designed for use with an insulating liner shall not have drain holes or access openings.

[https://standards.iteh.ai/catalog/standards/sist/78f239c6-2c2f-4024-9648-](https://standards.iteh.ai/catalog/standards/sist/78f239c6-2c2f-4024-9648-0b30b3f51443/iso-16653-2-2021)

4.5.4 Non-conductive (insulating) work platforms

A non-conductive (insulating) platform shall have no drain holes or access openings and shall be tested in accordance with the dielectric tests for insulating liners as defined in IEC 61057.

4.6 Electrical requirements

4.6.1 Non-conductive (insulating) components

All components crossing non-conductive (insulating) portions of the applicable MEWP shall have appropriate electrical insulating properties so that it conforms to the test requirements of this document. All non-conductive (insulating) systems shall maintain the electrical insulating values in all working boom positions, as defined by the responsible entity.

4.6.2 Hydraulic and pneumatic hose

All hydraulic and pneumatic hoses crossing the non-conductive (insulating) portion of the upper boom shall be tested in accordance with IEC 61057.

4.6.3 Lower test electrode system for MEWPs with non-conductive (insulating) components

MEWPs with non-conductive (insulating) components equipped with a lower test electrode system shall meet the lower test electrode system requirements of IEC 61057.

4.6.4 Chassis insulating system

MEWPs with a chassis insulating system shall have a means provided to bypass the chassis insulating system during dielectric tests. See [Figure 1](#).

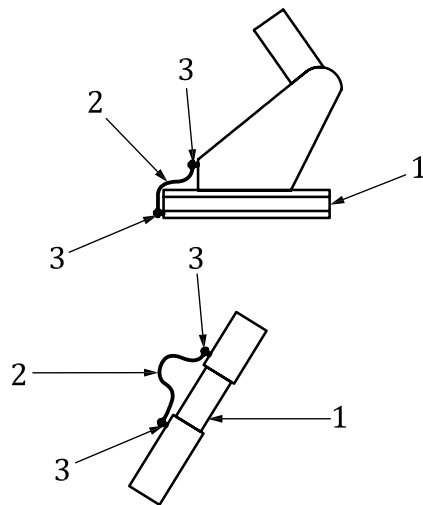

Key

- 1 insulating system
- 2 temporary shunt (to be removed after test)
- 3 stainless steel stud with 25 mm thread exposed

Figure 1 — Example of shunting arrangement for chassis insulating systems

ISO 16653-2:2021

<https://standards.iteh.ai/catalog/standards/sist/78f239c6-2c2f-4024-9648->

5 Verification of the safety requirements and/or protective/risk reduction measures

5.1 Examinations and tests

5.1.1 The MEWP shall conform to the safety requirements and/or protective measures of ISO 16368 and this document.

5.1.2 Examinations and tests shall consist of

- a) design checks (see [5.2](#)),
- b) manufacturing checks (see [5.3](#)), and
- c) tests (see [5.4](#)).

5.1.3 The results of examinations and tests shall be recorded.

5.2 Design check

The design check shall verify that the MEWP is designed in accordance with this document. It shall include verification of the following:

- a) drawings containing the main dimensions of the MEWP;
- b) description of the MEWP, with necessary information about its capabilities;
- c) information about the materials used;

- d) diagrams of the electrical, hydraulic and pneumatic circuits;
- e) the operator's manual;
- f) calculations.

5.3 Manufacturing check

The manufacturing check shall verify that

- a) the MEWP is manufactured in accordance with the design check documents,
- b) the components are in accordance with the drawings,
- c) test certificates are available for each type of rope, chain and hydraulic or pneumatic hose, and that these certificates indicate the minimum breaking force or bursting pressure, as appropriate,
- d) the quality of welds is ensured by use of the appropriate standard(s), and
- e) the construction and installation of parts, components and systems are in accordance with this document.

5.4 Tests

5.4.1 Dielectric tests

5.4.1.1 Test criteria for MEWPs with a non-conductive (insulating) boom

5.4.1.1.1 Each MEWP with non-conductive (insulating) upper boom shall undergo one of the tests described in [Table 1](#) to verify the insulating performance of the components of the non-conductive (insulating) boom assembly. This test can be conducted before or after installation on a chassis.

5.4.1.1.2 When a MEWP is modified or altered after the dielectric test prior to mounting, the test shall be performed again following the modification or alteration.

NOTE Modifications or alterations can include the addition of other devices (for example, another platform, a jib, a winch auxiliary devices).

5.4.1.2 Modifications and alterations

The installer shall acquire written approval from the responsible entity for modifications or alterations to verify that design testing requirements have been met.