



Designation: ~~D698-07~~^{ε1} Designation: **D698 - 12**

Standard Test Methods for Laboratory Compaction Characteristics of Soil Using Standard Effort (12 400 ft-lbf/ft³ (600 kN-m/m³))¹

This standard is issued under the fixed designation D698; the number immediately following the designation indicates the year of original adoption or, in the case of revision, the year of last revision. A number in parentheses indicates the year of last reapproval. A superscript epsilon (ϵ) indicates an editorial change since the last revision or reapproval.

This standard has been approved for use by agencies of the Department of Defense.

^{ε1}Note—~~Figure 2 was editorially corrected in July 2007.~~

1. Scope*

1.1 These test methods cover laboratory compaction methods used to determine the relationship between molding water content and dry unit weight of soils (compaction curve) compacted in a 4 or 6-in. (101.6 or 152.4-mm) diameter mold with a 5.50-lbf (24.5-N) rammer dropped from a height of 12.0 in. (305 mm) producing a compactive effort of 12 400 ft-lbf/ft³ (600 kN-m/m³).

NOTE 1—The equipment and procedures are similar as those proposed by R. R. Proctor (*Engineering News Record*—September 7, 1933) with this one major exception: his rammer blows were applied as “12 inch firm strokes” instead of free fall, producing variable compactive effort depending on the operator, but probably in the range 15 000 to 25 000 ft-lbf/ft³ (700 to 1200 kN-m/m³). The standard effort test (see 3.1.4) is sometimes referred to as the Proctor Test.

1.1.1 Soils and soil-aggregate mixtures are to be regarded as natural occurring fine- or coarse-grained soils, or composites or mixtures of natural soils, or mixtures of natural and processed soils or aggregates such as gravel or crushed rock. Hereafter referred to as either soil or material.

~~1.2 These~~ 1.2 These test methods apply only to soils (materials) that have 30 % or less by mass of particles retained on the ¾-in. (19.0-mm) sieve and have not been previously compacted in the laboratory; that is, do not reuse compacted soil.

1.2.1 For relationships between unit weights and molding water contents of soils with 30 % or less by mass of material retained on the ¾-in. (19.0-mm) sieve to unit weights and molding water contents of the fraction passing ¾-in. (19.0-mm) sieve, see Practice D4718.

~~1.3 Three~~ 1.3 Three alternative methods are provided. The method used shall be as indicated in the specification for the material being tested. If no method is specified, the choice should be based on the material gradation.

1.3.1 Method A:

1.3.1.1 *Mold*—4-in. (101.6-mm) diameter.

1.3.1.2 *Material*—Passing No. 4 (4.75-mm) sieve.

1.3.1.3 *Layers*—Three.

1.3.1.4 *Blows per Layer*—25.

1.3.1.5 *Usage*—May be used if 25 % or less (see Section 1.4) by mass of the material is retained on the No. 4 (4.75-mm) sieve.

1.3.1.6 *Other Usage*—If this gradation requirement cannot be met, then Method C may be used.

1.3.2 Method B:

1.3.2.1 *Mold*—4-in. (101.6-mm) diameter.

1.3.2.2 *Material*—Passing ⅜-in. (9.5-mm) sieve.

1.3.2.3 *Layers*—Three.

1.3.2.4 *Blows per Layer*—25.

1.3.2.5 *Usage*—May be used if 25 % or less (see Section 1.4) by mass of the material is retained on the ⅜-in. (9.5-mm) sieve.

1.3.2.6 *Other Usage*—If this gradation requirement cannot be met, then Method C may be used.

1.3.3 Method C:

1.3.3.1 *Mold*—6-in. (152.4-mm) diameter.

1.3.3.2 *Material*—Passing ¾-in. (19.0-mm) sieve.

1.3.3.3 *Layers*—Three.

¹ These Test Methods are under the jurisdiction of ASTM Committee D18 on Soil and Rock and are the direct responsibility of Subcommittee D18.03 on Texture, Plasticity and Density Characteristics of Soils.

Current edition approved April 15, 2007. Published July 2007. Originally approved in 1942. Last previous edition approved in 2000 as D698-00a.

Current edition approved May 1, 2012. Published June 2012. Originally approved in 1942. Last previous edition approved in 2007 as D698-07^{ε1}. DOI: 10.1520/D0698-07E01. DOI: 10.1520/D0698-12.

*A Summary of Changes section appears at the end of this standard.

1.3.3.4 *Blows per Layer*—56.

1.3.3.5 *Usage*—May be used if 30 % or less (see Section 1.4) by mass of the material is retained on the ¾-in. (19.0-mm) sieve.

1.3.4 The 6-in. (152.4-mm) diameter mold shall not be used with Method A or B.

NOTE 2—Results have been found to vary slightly when a material is tested at the same compactive effort in different size molds, with the smaller mold size typically yielding larger values of density/unit weight (1, pp. 21+).²

1.4 If the test specimen contains more than 5 % by mass of oversize fraction (coarse fraction) and the material will not be included in the test, corrections must be made to the unit mass and molding water content of the specimen or to the appropriate field-in-place density test specimen using Practice D4718.

1.5 This test method will generally produce a well-defined maximum dry unit weight for non-free draining soils. If this test method is used for free-draining soils the maximum unit weight may not be well defined, and can be less than obtained using Test Methods D4253.

1.6 All observed and calculated values shall conform to the guidelines for significant digits and rounding established in Practice D6026, unless superseded by this standard.

1.6.1 For purposes of comparing measured or calculated value(s) with specified limits, the measured or calculated value(s) shall be rounded to the nearest decimal or significant digits in the specified limits.

1.6.2 The procedures used to specify how data are collected/recorded or calculated, in this standard are regarded as the industry standard. In addition, they are representative of the significant digits that generally should be retained. The procedures used do not consider material variation, purpose for obtaining the data, special purpose studies, or any considerations for the user's objectives; and it is common practice to increase or reduce significant digits of reported data to be commensurate with these considerations. It is beyond the scope of this standard to consider significant digits used in analytical methods for engineering design.

1.7 The values in inch-pound units are to be regarded as the standard. The values stated in SI units are provided for information only, except for units of mass. The units for mass are given in SI units only, g or kg.

1.7.1 It is common practice in the engineering profession to concurrently use pounds to represent both a unit of mass (lbm) and a force (lbf). This implicitly combines two separate systems of units; that is, the absolute system and the gravitational system. It is scientifically undesirable to combine the use of two separate sets of inch-pound units within a single standard. This standard has been written using the gravitational system of units when dealing with the inch-pound system. In this system, the pound (lbf) represents a unit of force (weight). However, the use of balances or scales recording pounds of mass (lbm) or the recording of density in lbm/ft³ shall not be regarded as a nonconformance with this standard.

1.8 *This standard does not purport to address all of the safety concerns, if any, associated with its use. It is the responsibility of the user of this standard to establish appropriate safety and health practices and determine the applicability of regulatory limitations prior to use.*

2. Referenced Documents

2.1 *ASTM Standards*:³

- C127 [Test Method for Density, Relative Density \(Specific Gravity\), and Absorption of Coarse Aggregate](#)
- C136 [Test Method for Sieve Analysis of Fine and Coarse Aggregates](#)
- D653 [Terminology Relating to Soil, Rock, and Contained Fluids](#)
- D854 [Test Methods for Specific Gravity of Soil Solids by Water Pycnometer](#)
- D2168 [Practices for Calibration of Laboratory Mechanical-Rammer Soil Compactors](#)
- D2216 [Test Methods for Laboratory Determination of Water \(Moisture\) Content of Soil and Rock by Mass](#)
- D2487 [Practice for Classification of Soils for Engineering Purposes \(Unified Soil Classification System\)](#)
- D2488 [Practice for Description and Identification of Soils \(Visual-Manual Procedure\)](#)
- D3740 [Practice for Minimum Requirements for Agencies Engaged in Testing and/or Inspection of Soil and Rock as Used in Engineering Design and Construction](#)
- D4253 [Test Methods for Maximum Index Density and Unit Weight of Soils Using a Vibratory Table](#)
- D4718 [Practice for Correction of Unit Weight and Water Content for Soils Containing Oversize Particles](#)
- D4753 [Guide for Evaluating, Selecting, and Specifying Balances and Standard Masses for Use in Soil, Rock, and Construction Materials Testing](#)
- D4914 [Test Methods for Density and Unit Weight of Soil and Rock in Place by the Sand Replacement Method in a Test Pit](#)
- D5030 [Test Method for Density of Soil and Rock in Place by the Water Replacement Method in a Test Pit](#)
- D6026 [Practice for Using Significant Digits in Geotechnical Data](#)
- D6913 [Test Methods for Particle-Size Distribution \(Gradation\) of Soils Using Sieve Analysis](#)
- E11 [Specification for Woven Wire Test Sieve Cloth and Test Sieves](#)
- E177 [Practice for Use of the Terms Precision and Bias in ASTM Test Methods](#)

² The boldface numbers in parentheses refer to the list of references at the end of this standard.

³ For referenced ASTM standards, visit the ASTM website, www.astm.org, or contact ASTM Customer Service at service@astm.org. For *Annual Book of ASTM Standards* volume information, refer to the standard's Document Summary page on the ASTM website.

3. Terminology

3.1 Definitions:

3.1.1 See Terminology D653 for general definitions.

3.1.2 *molding water content, n* —the adjusted water content of a soil (material) that will be compacted/reconstituted.

3.1.3 *standard effort—in compaction testing*, the term for the 12 400 ft-lbf/ft³ (600 kN-m/m³) compactive effort applied by the equipment and methods of this test.

3.1.4 *standard maximum dry unit weight, $\gamma_{d,max}$* in lbf/ft³ (kN/m³)—*in compaction testing*, the maximum value defined by the compaction curve for a compaction test using standard effort.

3.1.5 *standard optimum water content, w_{opt}* in %—*in compaction testing*, the molding water content at which a soil can be compacted to the maximum dry unit weight using standard compactive effort.

3.2 Definitions of Terms Specific to This Standard:

3.2.1 *oversize fraction (coarse fraction), P_C* in % —the portion of total specimen not used in performing the compaction test; it may be the portion of total specimen retained on the No. 4 (4.75-mm) sieve in Method A, 3/8-in. (9.5-mm) sieve in Method B, or 3/4-in. (19.0-mm) sieve in Method C.

3.2.2 *test fraction (finer fraction), P_F* in % —the portion of the total specimen used in performing the compaction test; it is the fraction passing the No. 4 (4.75-mm) sieve in Method A, passing the 3/8-in. (9.5-mm) sieve in Method B, or passing the 3/4-in. (19.0-mm) sieve in Method C.

4. Summary of Test Method

4.1 A soil at a selected molding water content is placed in three layers into a mold of given dimensions, with each layer compacted by 25 or 56 blows of a 5.50-lbf (24.47-N) rammer dropped from a distance of 12.00 in. (304.8 mm), subjecting the soil to a total compactive effort of about 12 400 ft-lbf/ft³ (600 kN-m/m³). The resulting dry unit weight is determined. The procedure is repeated for a sufficient number of molding water contents to establish a relationship between the dry unit weight and the molding water content for the soil. This data, when plotted, represents a curvilinear relationship known as the compaction curve. The values of optimum water content and standard maximum dry unit weight are determined from the compaction curve.

5. Significance and Use

5.1 Soil placed as engineering fill (embankments, foundation pads, road bases) is compacted to a dense state to obtain satisfactory engineering properties such as, shear strength, compressibility, or permeability. In addition, foundation soils are often compacted to improve their engineering properties. Laboratory compaction tests provide the basis for determining the percent compaction and molding water content needed to achieve the required engineering properties, and for controlling construction to assure that the required compaction and water contents are achieved.

5.2 During design of an engineered fill, shear, consolidation, permeability, or other tests require preparation of test specimens by compacting at some molding water content to some unit weight. It is common practice to first determine the optimum water content (w_{opt}) and maximum dry unit weight ($\gamma_{d,max}$) by means of a compaction test. Test specimens are compacted at a selected molding water content (w), either wet or dry of optimum (w_{opt}) or at optimum (w_{opt}), and at a selected dry unit weight related to a percentage of maximum dry unit weight ($\gamma_{d,max}$). The selection of molding water content (w), either wet or dry of optimum (w_{opt}) or at optimum (w_{opt}) and the dry unit weight ($\gamma_{d,max}$) may be based on past experience, or a range of values may be investigated to determine the necessary percent of compaction.

5.3 Experience indicates that the methods outlined in 5.2 or the construction control aspects discussed in 5.1 are extremely difficult to implement or yield erroneous results when dealing with certain soils. 5.3.1-5.3.3 describe typical problem soils, the problems encountered when dealing with such soils and possible solutions for these problems.

5.3.1 *Oversize Fraction*—Soils containing more than 30 % oversize fraction (material retained on the 3/4-in. (19-mm) sieve) are a problem. For such soils, there is no ASTM test method to control their compaction and very few laboratories are equipped to determine the laboratory maximum unit weight (density) of such soils (USDI Bureau of Reclamation, Denver, CO and U.S. Army Corps of Engineers, Vicksburg, MS). Although Test Methods D4914 and D5030 determine the “field” dry unit weight of such soils, they are difficult and expensive to perform.

5.3.1.1 One method to design and control the compaction of such soils is to use a test fill to determine the required degree of compaction and the method to obtain that compaction, followed by use of a method specification to control the compaction. Components of a method specification typically contain the type and size of compaction equipment to be used, the lift thickness, acceptable range in molding water content, and the number of passes.

NOTE 3—Success in executing the compaction control of an earthwork project, especially when a method specification is used, is highly dependent upon the quality and experience of the contractor and inspector.

5.3.1.2 Another method is to apply the use of density correction factors developed by the USDI Bureau of Reclamation (2,3) and U.S. Corps of Engineers (4). These correction factors may be applied for soils containing up to about 50 to 70 % oversize

fraction. Each agency uses a different term for these density correction factors. The USDI Bureau of Reclamation uses *D* ratio (or *D*-VALUE), while the U.S. Corps of Engineers uses Density Interference Coefficient (*I_c*).

5.3.1.3 The use of the replacement technique (Test Method D698–78, Method D), in which the oversize fraction is replaced with a finer fraction, is inappropriate to determine the maximum dry unit weight, $\gamma_{d,max}$, of soils containing oversize fractions (4).

5.3.2 *Degradation*—Soils containing particles that degrade during compaction are a problem, especially when more degradation occurs during laboratory compaction than field compaction, as is typical. Degradation typically occurs during the compaction of a granular-residual soil or aggregate. When degradation occurs, the maximum dry-unit weight increases (1, p. 73) so that the laboratory maximum value is not representative of field conditions. Often, in these cases, the maximum dry unit weight is impossible to achieve in the field.

5.3.2.1 Again, for soils subject to degradation, the use of test fills and method specifications may help. Use of replacement techniques is not correct.

5.3.3 *Gap Graded*—Gap-graded soils (soils containing many large particles with limited small particles) are a problem because the compacted soil will have larger voids than usual. To handle these large voids, standard test methods (laboratory or field) typically have to be modified using engineering judgement.

NOTE 4—The quality of the result produced by this standard is dependent on the competence of the personnel performing it, and the suitability of the equipment and facilities used. Agencies that meet the criteria of Practice D3740 are generally considered capable of competent and objective testing/sampling/inspection, and the like. Users of this standard are cautioned that compliance with Practice D3740 does not in itself assure reliable results. Reliable results depend on many factors; Practice D3740 provides a means of evaluating some of those factors.

6. Apparatus

6.1 *Mold Assembly*—The molds shall be cylindrical in shape, made of rigid metal and be within the capacity and dimensions indicated in 6.1.1 or 6.1.2 and Figs. 1 and 2. See also Table 1. The walls of the mold may be solid, split, or tapered. The “split” type may consist of two half-round sections, or a section of pipe split along one element, which can be securely locked together to form a cylinder meeting the requirements of this section. The “tapered” type shall have an internal diameter taper that is uniform and not more than 0.200 in./ft (16.7 mm/m) of mold height. Each mold shall have a base plate and an extension collar assembly, both made of rigid metal and constructed so they can be securely attached and easily detached from the mold. The extension collar assembly shall have a height extending above the top of the mold of at least 2.0 in. (51 mm) which may include an upper section that flares out to form a funnel, provided there is at least a 0.75 in. (19 mm) straight cylindrical section beneath it. The extension collar shall align with the inside of the mold. The bottom of the base plate and bottom of the centrally recessed area that accepts the cylindrical mold shall be planar within ± 0.005 in. (± 0.1 mm).

6.1.1 *Mold, 4 in.*—A mold having a 4.000 ± 0.016 -in. (101.6 ± 0.4 -mm) average inside diameter, a height of 4.584 ± 0.018 in. (116.4 ± 0.5 mm) and a volume of 0.0333 ± 0.0005 ft³ (943.0 ± 14 cm³). A mold assembly having the minimum required features is shown in Fig. 1.

6.1.2 *Mold, 6 in.*—A mold having a 6.000 ± 0.026 -in. (152.4 ± 0.7 -mm) average inside diameter, a height of 4.584 ± 0.018 in. (116.4 ± 0.5 mm), and a volume of 0.0750 ± 0.0009 ft³ (2124 ± 25 cm³). A mold assembly having the minimum required features is shown in Fig. 2.

6.2 *Rammer*—A rammer, either manually operated as described further in 6.2.1 or mechanically operated as described in 6.2.2. The rammer shall fall freely through a distance of 12.00 ± 0.05 in. (304.8 ± 1 mm) from the surface of the specimen. The weight of the rammer shall be 5.50 ± 0.02 lbf (24.47 ± 0.09 N, or mass of 2.495 ± 0.023 kg), except that the weight of the mechanical rammers may be adjusted as described in Test Methods Practices D2168; see Note 5. The striking face of the rammer shall be planar and circular, except as noted in 6.2.2.1, with a diameter when new of 2.000 ± 0.005 in. (50.80 ± 0.13 mm). The rammer shall be replaced if the striking face becomes worn or bellied to the extent that the diameter exceeds 2.000 ± 0.01 in. (50.80 ± 0.25 mm).

NOTE 5—It is a common and acceptable practice to determine the weight of the rammer using either a kilogram or pound balance and assume 1 lbf is equivalent to 0.4536 kg, 1 lbf is equivalent to 1 lbf, or 1 N is equivalent to 0.2248 lbf or 0.1020 kg.

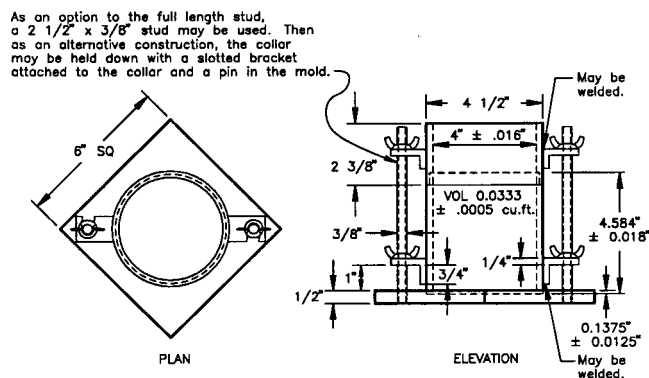

FIG. 1 4.0-in. Cylindrical Mold

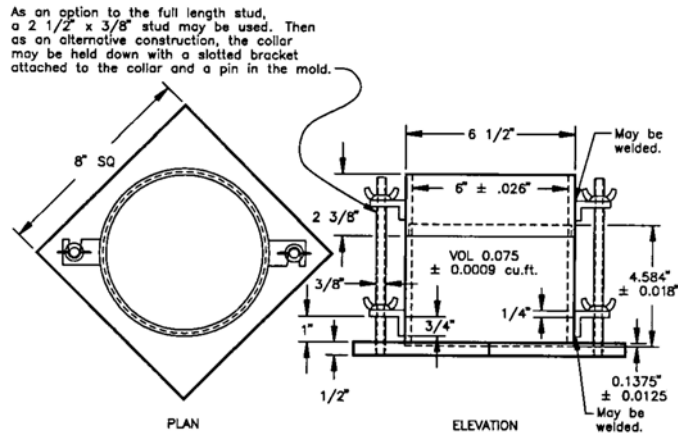

FIG. 2 6.0-in. Cylindrical Mold

TABLE 1 Metric Equivalents for Figs. 1 and 2

in.	mm
0.016	0.41
0.026	0.66
0.032	0.81
0.028	0.71
1/2	12.70
2 1/2	63.50
2 5/8	66.70
4	101.60
4 1/2	114.30
4.584	116.43
4 3/4	120.60
6	152.40
6 1/2	165.10
6 5/8	168.30
6 3/4	171.40
8 1/4	209.60
ft ³	cm ³
1/30 (0.0333)	943
0.0005	14
(0.0750)	2,124
0.0011	31

<https://standards.iteh.ai/catalog/standards/sist/28b72c6a-e813-42c0-9116-0e15a2647c11/astm-d698-12>

6.2.1 *Manual Rammer*—The rammer shall be equipped with a guide sleeve that has sufficient clearance that the free fall of the rammer shaft and head is not restricted. The guide sleeve shall have at least four vent holes at each end (eight holes total) located with centers 3/4 ± 1/16 in. (19 ± 2 mm) from each end and spaced 90 degrees apart. The minimum diameter of the vent holes shall be 3/8 in. (9.5 mm). Additional holes or slots may be incorporated in the guide sleeve.

6.2.2 *Mechanical Rammer-Circular Face*—The rammer shall operate mechanically in such a manner as to provide uniform and complete coverage of the specimen surface. There shall be 0.10 ± 0.03-in. (2.5 ± 0.8-mm) clearance between the rammer and the inside surface of the mold at its smallest diameter. The mechanical rammer shall meet the standardization/calibration requirements of Test Methods Practices D2168. The mechanical rammer shall be equipped with a positive mechanical means to support the rammer when not in operation.

6.2.2.1 *Mechanical Rammer-Sector Face*—The sector face shall can be used with the 6-in. (152.4-mm) mold, in place of as an alternative to the circular face mechanical rammer described in 6.2.2. The striking face shall have the shape of a sector of a circle of radius equal to 2.90 ± 0.02-in. (73.7 ± 0.5 mm) and an area about the same as the circular face, see 6.2. The rammer shall operate in such a manner that the vertex of the sector is positioned at the center of the specimen. The rammer shall operate in such a manner that the vertex of the sector is positioned at the center of the specimen and follow the compaction pattern given in Fig. 3b.

6.3 *Sample Extruder (optional)*—A jack, with frame or other device adapted for the purpose of extruding compacted specimens from the mold.

6.4 *Balance*—A Class GP5 balance meeting the requirements of Specification D4753 for a balance of 1-g readability. If the water content of the compacted specimens is determined using a representative portion of the specimen, rather than the whole specimen, and if the representative portion is less than 1000 g, a Class GP2 balance having a 0.1-g readability is needed in order to comply with Test Methods D2216 requirements for determining water content to 0.1 %.

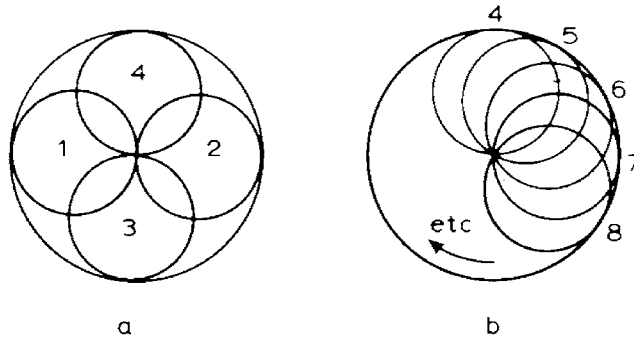

FIG. 3 Rammer Pattern for Compaction in 4 in. (101.6 mm) Mold

NOTE 6—Use of a balance having an equivalent capacity and a readability of 0.002 lbm as an alternative to a class GP5 balance should not be regarded as nonconformance to this standard.

6.5 *Drying Oven*—Thermostatically controlled oven, capable of maintaining a uniform temperature of $230 \pm 9^\circ\text{F}$ ($110 \pm 5^\circ\text{C}$) throughout the drying chamber. These requirements typically require the use of a forced-draft type oven. Preferably the oven should be vented outside the building.

6.6 *Straightedge*—A stiff metal straightedge of any convenient length but not less than 10 in. (250 mm). The total length of the straightedge shall be machined straight to a tolerance of ± 0.005 in. (± 0.1 mm). The scraping edge shall be beveled if it is thicker than $\frac{1}{8}$ in. (3 mm).

6.7 *Sieves*— $\frac{3}{4}$ in. (19.0 mm), $\frac{3}{8}$ in. (9.5 mm), and No. 4 (4.75 mm), conforming to the requirements of Specification E11.

6.8 *Mixing Tools*—Miscellaneous tools such as mixing pan, spoon, trowel, spatula, spraying device (to add water evenly), and (preferably, but optional) suitable mechanical device for thoroughly mixing the subspecimen of soil with increments of water.

7. Standardization/Calibration

7.1 Perform standardizations before initial use, after repairs or other occurrences that might affect the test results, at intervals not exceeding 1,000 test specimens, or annually, whichever occurs first, for the following apparatus:

7.1.1 *Balance*—Evaluate in accordance with Specification D4753.

7.1.2 *Molds*—Determine the volume as described in Annex A1.

7.1.3 *Manual Rammer*—Verify the free fall distance, rammer weight, and rammer face are in accordance with 6.2. Verify the guide sleeve requirements are in accordance with 6.2.1.

7.1.4 *Mechanical Rammer*—Verify and adjust if necessary that the mechanical rammer is in accordance with Test Method Practices D2168. In addition, the clearance between the rammer and the inside surface of the mold shall be verified in accordance with 6.2.2.

8. Test Specimen

8.1 The minimum specimen (test fraction) mass for Methods A and B is about 16 kg, and for Method C is about 29 kg of dry soil. Therefore, the field sample should have a moist mass of at least 23 kg and 45 kg, respectively. Greater masses would be required if the oversize fraction is large (see 10.2 or 10.3) or an additional molding water content is taken during compaction of each point (see 10.4.2.1).

8.2 If gradation data is not available, estimate the percentage of material (by mass) retained on the No. 4 (4.75-mm), $\frac{3}{8}$ -in. (9.5-mm), or $\frac{3}{4}$ -in. (19.0-mm) sieve as appropriate for selecting Method A, B, or C, respectively. If it appears the percentage retained of interest is close to the allowable value for a given Method (A, B, or C), then either:

8.2.1 Select a Method that allows a higher percentage retained (B or C).

8.2.2 Using the Method of interest, process the specimen in accordance with 10.2 or 10.3, this determines the percentage retained for that method. If acceptable, proceed, if not go to the next Method (B or C).

8.2.3 Determine percentage retained values by using a representative portion from the total sample, and performing a simplified or complete gradation analysis using the sieve(s) of interest and Test Method D6913 or C136. It is only necessary to calculate the retained percentage(s) for the sieve or sieves for which information is desired.

9. Preparation of Apparatus

9.1 Select the proper compaction mold(s), collar, and base plate in accordance with the Method (A, B, or C) being used. Check that its volume is known and determined with or without base plate, free of nicks or dents, and will fit together properly.

NOTE 7—Mass requirements are given in 10.4.

9.2 Check that the manual or mechanical rammer assembly is in good working condition and that parts are not loose or worn. Make any necessary adjustments or repairs. If adjustments or repairs are made, the rammer must be re-standardized.