



Designation: F2322–03 Designation: F2322 – 12

Standard Test Methods for Physical Assault on Vertical Fixed Barriers for Detention and Correctional Facilities¹

This standard is issued under the fixed designation F2322; the number immediately following the designation indicates the year of original adoption or, in the case of revision, the year of last revision. A number in parentheses indicates the year of last reapproval. A superscript epsilon (ϵ) indicates an editorial change since the last revision or reapproval.

1. Scope

1.1 These test methods cover requirements for simulated service tests and testing equipment for determining the performance characteristics of walls designed to incarcerate inmates in detention and correctional institutions. The testing equipment provides for the setup and testing of two sample fixed barriers side-by-side, one with no openings and one equipped with a representative penetration in accordance with the American Correctional Association (ACA) standard for clear view area of 3 ft² (0.279 m²), 12 in. (305 mm) wide by 36 in. (914 mm) high.

1.2 It is the intent of these test methods to help ensure that detention security walls perform at or above minimum acceptable levels to control passage of unauthorized or secure areas, to confine inmates, to delay and frustrate escape attempts, and to resist vandalism. It is recognized that in order to meet the intent of these test methods, opening assemblies within these walls must be compatible with the level of performance required by: Test Methods F1450, F1592, and F1643.

1.3 These test methods apply to walls enclosing or separating secure areas of detention/correctional facilities.

1.4 The values stated in inch-pound units are to be regarded as the standard. The SI values given in parentheses are approximate and for information only.

1.5 *This standard does not purport to address all of the safety concerns, if any, associated with its use. It is the responsibility of the user of this standard to establish appropriate safety and health practices and determine the applicability of regulatory limitations prior to use.*

2. Referenced Documents

2.1 ASTM Standards:²

F1450 Test Methods for Hollow Metal Swinging Door Assemblies for Detention and Correctional Facilities

F1592 Test Methods for Detention Hollow Metal Vision Systems

F1643 Test Methods for Detention Sliding Door Locking Device Assembly

F1915 Test Methods for Glazing for Detention Facilities¹ F2322-12

2.2 UL Standard:

UL-752 Bullet Resisting Equipment³

2.3 ANSI Standard:

ANSI/HMMA 863 Guide Specifications for Detention Security Hollow Metal Doors and Frames⁴

3. Terminology

3.1 Definitions:

3.1.1 *detention security*—assurance of the restriction of mobility of inmates to designated areas within a correctional or detention facility.

3.1.2 *forcible egress*—an opening created in the test wall which allows a 5 in. (127 mm) by 8 in. (203 mm) by 8 in. (203 mm) rigid rectangular box to be passed through it with no more than 10 lbf (44.5 N) of force.

3.1.3 *manufacturer*—the party responsible for the construction, fabrication, or supply of the test samples or components used to construct the test samples.

¹ These test methods are under the jurisdiction of ASTM Committee F33 on Detention and Correctional Facilities and are the direct responsibility of Subcommittee F33.02 on Physical Barriers.

Current edition approved July 10, 2003. Published August 2003. DOI: 10.1520/F2322-03.

Current edition approved June 1, 2012. Published June 2012. Last previous edition approved in 2003 as F2322 – 03 which was withdrawn January 2012 and reinstated in June 2012. DOI: 10.1520/F2322-12.

² For referenced ASTM standards, visit the ASTM website, www.astm.org, or contact ASTM Customer Service at service@astm.org. For *Annual Book of ASTM Standards* volume information, refer to the standard's Document Summary page on the ASTM website.

³ Available from Underwriters Laboratories (UL), Corporate Progress, 333 Pfingsten Rd., Northbrook, IL 60062.

⁴ Available from American National Standards Institute (ANSI), 25 W. 43rd St., 4th Floor, New York, NY 10036.

3.1.4 *performance characteristic*—the response of the wall in any one of the tests described herein.

3.1.5 *test completion*—conduct one test sequence for each wall.

3.1.6 *testing laboratory*—an independent third party materials testing laboratory.

4. Significance and Use

4.1 A major concern for administrative officials is the security of barriers used in detention/correctional facilities. These test methods are designed to aid in identifying levels of physical security for walls which enclose or separate secure areas. This does not apply to the passage of contraband.

4.2 These test methods are not intended to provide a measure of resistance for a wall subjected to attack by corrosive agents, by high-powered rifles, explosives, sawing, or other such methods. These test methods are intended to evaluate the resistance of a wall to violent attacks by sustained manpower using battering devices, such as benches, bunks, or tables, and by handguns up to and including .44 magnum. Attacks from the outside and fire resistance ratings are not addressed in this standard.

4.3 The primary purpose or result of these test methods is to approximate the levels of abuse to which walls will potentially be subjected in the field. The desired result of its use is to help provide assurance of protection to the public, to facility administrative personnel, and to the inmates themselves.

4.4 It is recommended that detention/correctional facility administration provide adequate training, supervision, and preventative maintenance programs to enable walls to function as intended throughout the expected service life.

5. Sampling

5.1 Sample wall shall be constructed in accordance with 6.1.

5.2 Test reports shall include complete details of the test samples, details, photographs, or a combination thereof, of the testing apparatus and installation or construction instructions (see Section 9).

5.3 In the event of failure in one or more of the performance tests, the manufacturer shall provide another complete test sample or shall continue testing in another location on the wall, subject to the direction of the testing laboratory.

6. Specimen Preparation

6.1 *Construction:*

6.1.1 The construction of the test wall shall be representative of the wall as it will be placed in service.

6.1.2 Required results indicated in Table 1 are based upon a sample size of 8 ft (2438 mm) high by 8 ft (2438 mm) wide \pm 4 in. (102 mm).

6.2 *Impact Test Fixture:*

6.2.1 The test wall support fixture shall simulate the rigidity normally provided to a wall in a building by the ceiling, floor, and adjoining walls (Figs. 1-4). The inclusion of load bearing conditions on the test wall is at the manufacturers' option.

6.2.2 The fixture is designed to accommodate two test samples; however, it is permissible to construct a test fixture that accommodates one sample only, if the manufacturer so chooses.

6.2.3 *Description of the Test Wall*—The test wall shall be constructed and mounted in a vertical wall test fixture and shall be supported as described in 6.2.1 throughout the testing procedure. The wall specification shall be included as part of the test report.

6.3 *Wall Construction or Mounting for Impact Testing:*

6.3.1 Construct or install the test walls as shown in Figs. 1-4. Position the impact test ram on the outside of the fixture in preparation to administer the series of impacts described in 7.2.

7. Procedures

7.1 *Bullet Penetration:*

7.1.1 *Scope*—This test is designed to evaluate the capability of a test wall to resist the ballistic attack of a .44 magnum (Level 3) handgun.

7.1.2 *Significance and Use*—This test is intended to simulate a field situation whereby one or more firearms are being used to attack a fixed barrier. The handgun is considered the most reasonably attainable firearm and the calibre, .44 magnum, is considered to be the most powerful that will potentially be reasonably attainable during a mass disturbance or riot within a detention or correctional facility.

TABLE 1 Security Grades and Impact Load Requirements

Grade No.	Number of Impacts ^A	Representative Barrier Duration Time (see X4.1)
1	600	60 min.
2	400	40 min.
3	200	20 min.
4	100	10 min.

^A Number of impacts equally divided between blunt impactor (first sequence) and sharp impactor, applied in cyclic sequences of 50 impacts each.

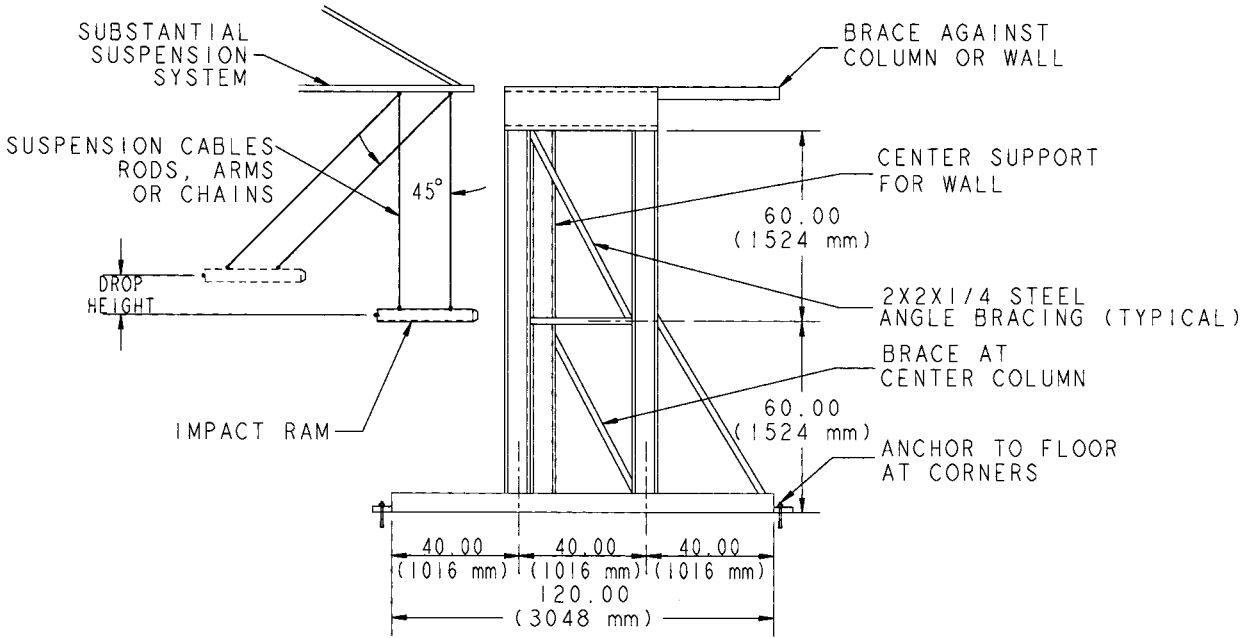

FIG. 1 Fixture and Test Wall Panels—Side View

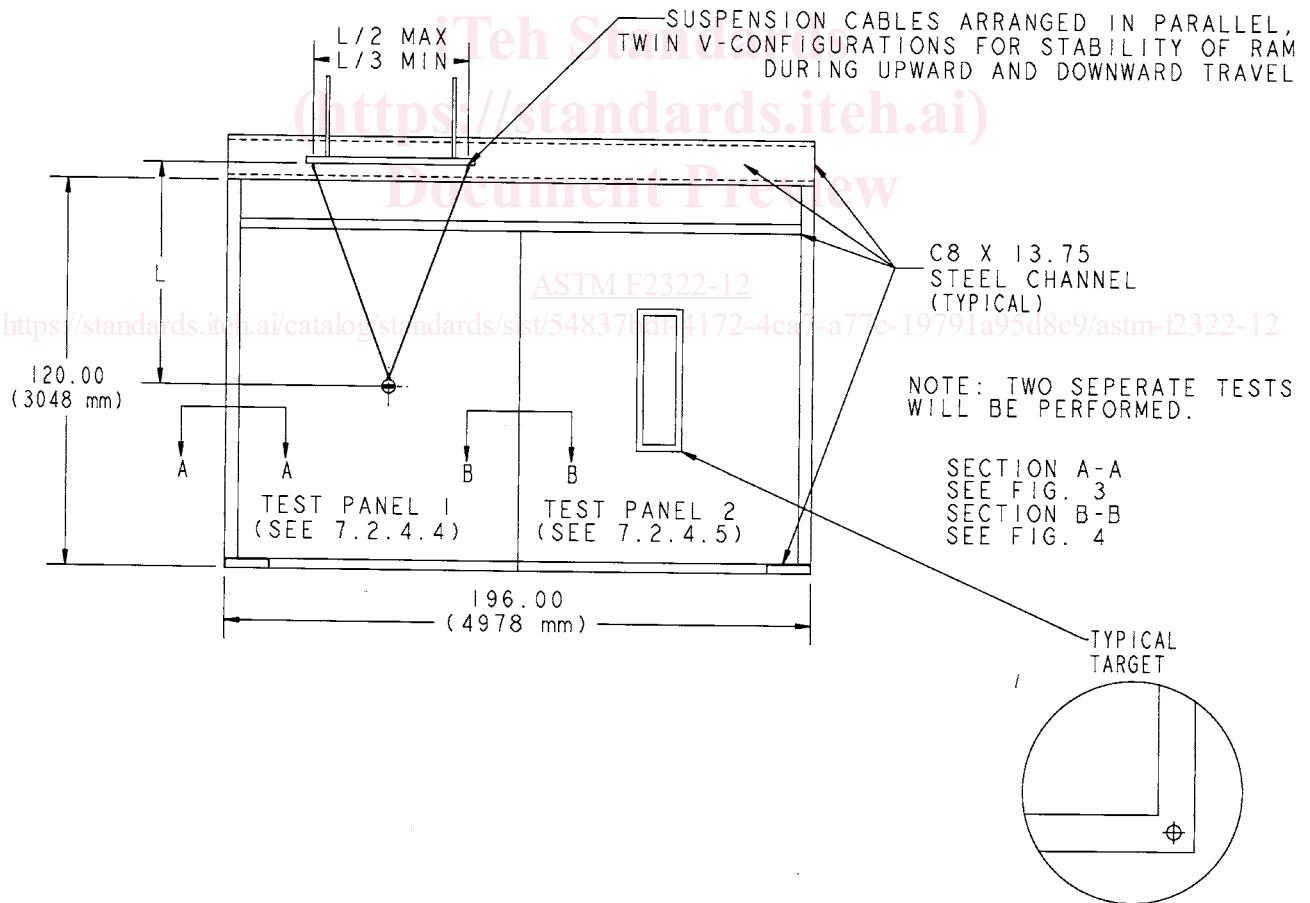

FIG. 2 Fixture and Test Wall Panels—Front View

7.1.3 When specified by the contract documents of a detention/correctional facility project, the wall samples for bullet penetration shall be tested in accordance with Standard UL-752. A representative sample based upon the wall construction under investigation shall be tested. Minimum size shall be 3 ft, 0 in. (914 mm) by 3 ft, 0 in. (914 mm).

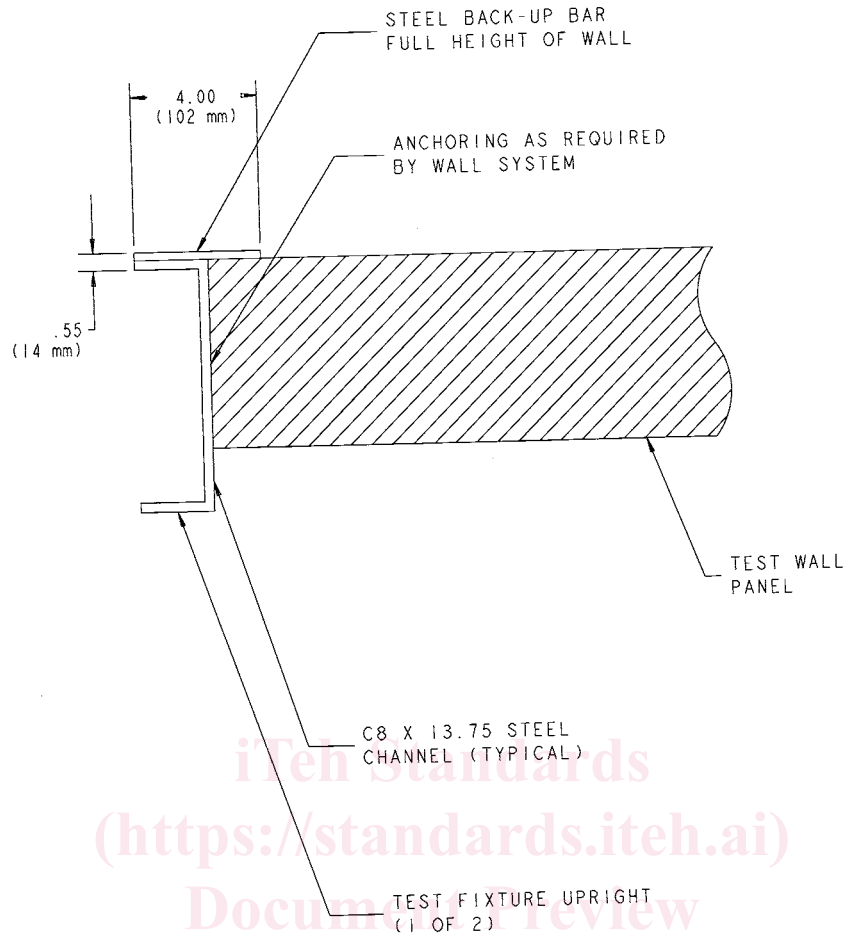

FIG. 3 Section A-A from Fig. 2

ASTM F2322-12

<https://standards.iteh.ai/catalog/standards/sist/54837bdf-4172-4ca7-a77c-19791a95d8c9/astm-f2322-12>

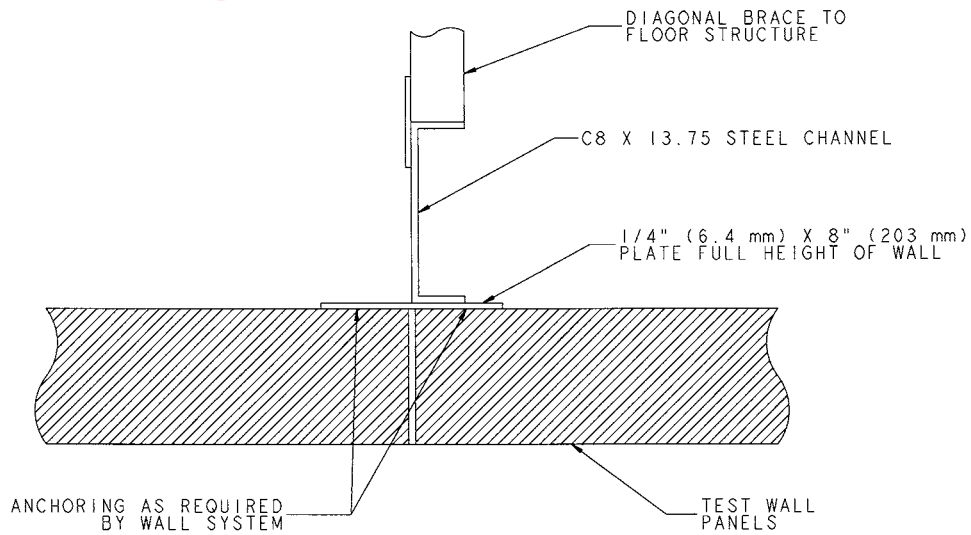

FIG. 4 Section B-B from Fig. 2

7.1.4 The level of performance shall meet the rating .44 magnum, Level 3.

7.1.5 The pass/fail criteria shall be in accordance with Standard UL-752.

7.2 Wall System Impact Test: