Coating powders —

Part 5:

**Determination of flow properties of a
powder/air mixture**

Poudres pour revêtement —

*Partie 5: Détermination de l'aptitude à la fluidisation d'un mélange
poudre/air*

**iTeh STANDARD PREVIEW
(standards.iteh.ai)**

[ISO/PRF 8130-5](https://standards.iteh.ai/catalog/standards/sist/2c08a595-ec36-4057-a609-b14404d72a62/iso-prf-8130-5)

[https://standards.iteh.ai/catalog/standards/sist/2c08a595-ec36-4057-a609-
b14404d72a62/iso-prf-8130-5](https://standards.iteh.ai/catalog/standards/sist/2c08a595-ec36-4057-a609-b14404d72a62/iso-prf-8130-5)

PROOF / ÉPREUVE



Reference number
ISO 8130-5:2021(E)

iTeh STANDARD PREVIEW (standards.iteh.ai)

ISO/PRF 8130-5

<https://standards.iteh.ai/catalog/standards/sist/2c08a595-ec36-4057-a609-b14404d72a62/iso-prf-8130-5>



COPYRIGHT PROTECTED DOCUMENT

© ISO 2021

All rights reserved. Unless otherwise specified, or required in the context of its implementation, no part of this publication may be reproduced or utilized otherwise in any form or by any means, electronic or mechanical, including photocopying, or posting on the internet or an intranet, without prior written permission. Permission can be requested from either ISO at the address below or ISO's member body in the country of the requester.

ISO copyright office
CP 401 • Ch. de Blandonnet 8
CH-1214 Vernier, Geneva
Phone: +41 22 749 01 11
Email: copyright@iso.org
Website: www.iso.org

Published in Switzerland

Contents

| | Page |
|--|----------|
| Foreword | iv |
| 1 Scope | 1 |
| 2 Normative references | 1 |
| 3 Terms and definitions | 1 |
| 4 Principle | 1 |
| 5 Apparatus | 1 |
| 6 Sampling | 3 |
| 7 Procedure | 4 |
| 7.1 Calibration of apparatus | 4 |
| 7.2 Determination of flow properties | 4 |
| 8 Expression of results | 4 |
| 9 Precision | 5 |
| 10 Test report | 5 |

iTeh STANDARD PREVIEW (standards.iteh.ai)

[ISO/PRF 8130-5](https://standards.iteh.ai/catalog/standards/sist/2c08a595-ec36-4057-a609-b14404d72a62/iso-prf-8130-5)

<https://standards.iteh.ai/catalog/standards/sist/2c08a595-ec36-4057-a609-b14404d72a62/iso-prf-8130-5>

Foreword

ISO (the International Organization for Standardization) is a worldwide federation of national standards bodies (ISO member bodies). The work of preparing International Standards is normally carried out through ISO technical committees. Each member body interested in a subject for which a technical committee has been established has the right to be represented on that committee. International organizations, governmental and non-governmental, in liaison with ISO, also take part in the work. ISO collaborates closely with the International Electrotechnical Commission (IEC) on all matters of electrotechnical standardization.

The procedures used to develop this document and those intended for its further maintenance are described in the ISO/IEC Directives, Part 1. In particular, the different approval criteria needed for the different types of ISO documents should be noted. This document was drafted in accordance with the editorial rules of the ISO/IEC Directives, Part 2 (see www.iso.org/directives).

Attention is drawn to the possibility that some of the elements of this document may be the subject of patent rights. ISO shall not be held responsible for identifying any or all such patent rights. Details of any patent rights identified during the development of the document will be in the Introduction and/or on the ISO list of patent declarations received (see www.iso.org/patents).

Any trade name used in this document is information given for the convenience of users and does not constitute an endorsement.

For an explanation of the voluntary nature of standards, the meaning of ISO specific terms and expressions related to conformity assessment, as well as information about ISO's adherence to the World Trade Organization (WTO) principles in the Technical Barriers to Trade (TBT), see www.iso.org/iso/foreword.html.

This document was prepared by Technical Committee ISO/TC 35, *Paints and varnishes*, Subcommittee SC 9, *General test methods for paints and varnishes*, in collaboration with the European Committee for Standardization (CEN) Technical Committee CEN/TC 139, *Paints and varnishes*, in accordance with the Agreement on technical cooperation between ISO and CEN (Vienna Agreement).

This second edition cancels and replaces the first edition (ISO 8130-5:1992), which has been technically revised. The main changes compared to the previous edition are as follows:

- the scope has been revised editorially;
- Annex A has been deleted;
- [Clause 3](#) on terms and definitions has been added;
- requirements for test temperature and humidity have been introduced;
- the text has been editorially revised and the normative references have been updated.

A list of all parts in the ISO 8130 series can be found on the ISO website.

Any feedback or questions on this document should be directed to the user's national standards body. A complete listing of these bodies can be found at www.iso.org/members.html

Coating powders —

Part 5:

Determination of flow properties of a powder/air mixture

1 Scope

This document specifies a method for estimating the flow properties of a mixture of coating powder and air.

The results obtained are influenced by the composition of the coating powder, its density, particle size distribution and particle shape, together with the tendency of the particles to agglomerate and to accept a charge.

2 Normative references

The following documents are referred to in the text in such a way that some or all of their content constitutes requirements of this document. For dated references, only the edition cited applies. For undated references, the latest edition of the referenced document (including any amendments) applies.

ISO 8130-14, *Coating powders — Part 14: Vocabulary*

ISO 15528, *Paints, varnishes and raw materials for paints and varnishes — Sampling*

[ISO/PRF 8130-5](https://standards.iteh.ai/catalog/standards/sist/2c08a595-ec36-4057-a609-b14404d72a62/iso-prf-8130-5)

3 Terms and definitions

<https://standards.iteh.ai/catalog/standards/sist/2c08a595-ec36-4057-a609-b14404d72a62/iso-prf-8130-5>

For the purposes of this document, the terms and definitions given in ISO 8130-14 apply.

ISO and IEC maintain terminological databases for use in standardization at the following addresses:

- ISO Online browsing platform: available at <https://www.iso.org/obp>
- IEC Electropedia: available at <http://www.electropedia.org/>

4 Principle

A specified quantity of coating powder is placed in a vessel and is fluidized with clean dry air under known conditions of temperature, humidity and atmospheric pressure. The height of the powder during and after fluidization is measured and the mass at which the fluidized powder flows through a specified orifice during a specified interval of time is then determined.

The measurements are used to calculate the fluidization factor, ϕ , and the powder flow rate, R , which together define the transport and spraying characteristics of the powder.

5 Apparatus

Ordinary laboratory apparatus, together with the following.

5.1 Apparatus for the determination of flow properties, consisting of a fluidization vessel with a circular opening in the wall, a device for measuring the height of powder in the vessel and a collecting receptacle for weighing the amount of powder that flows through the orifice.

An example of a suitable apparatus is shown in [Figure 1](#).

A typical apparatus consists of the elements described in [5.1.1](#) to [5.1.3](#).

5.1.1 Vessel for fluidizing the powder (vessel A), outer diameter approximately 110 mm, inner diameter approximately 100 mm, height not less than approximately 200 mm, for example made of transparent poly(methyl methacrylate) and having a bottom made of a suitable material of uniform porosity and a maximum pore size of approximately 40 µm diameter.

To avoid difficulties when cleaning the bottom of the vessel or due to plugging, it is recommended that unit G is removable (e.g. by a screw joint) for air admission (beneath the porous bottom of the container A).

NOTE A disc of 5 mm thickness capable of passing air at a rate of approximately (200 ± 10) l/h under a pressure of 5 kPa above atmospheric has been found to be satisfactory.

A 4 mm-diameter circular opening D that can be closed with stopper E shall be situated in the wall of the vessel, 10 mm above the top of the porous disc.

5.1.2 Air regulation unit B, with flowmeter F for adjusting the air flow.

5.1.3 Container C, sufficiently large to collect the powder discharged during measurement of the flow factor (see [Figure 1](#)).

iTeh STANDARD PREVIEW
(standards.iteh.ai)

5.2 Clean dry compressed air.

[ISO/PRF 8130-5](#)

5.3 Timer, accurate to 1 s.

<https://standards.iteh.ai/catalog/standards/sist/2c08a595-ec36-4057-a609-b14404d72a62/iso-prf-8130-5>

5.4 Analytical balance, of capacity 500 g, capable of weighing to 0,1 g.

5.5 Ruler, preferably made of metal, graduated in millimetres.

5.6 Spatula.

Dimensions in millimetres

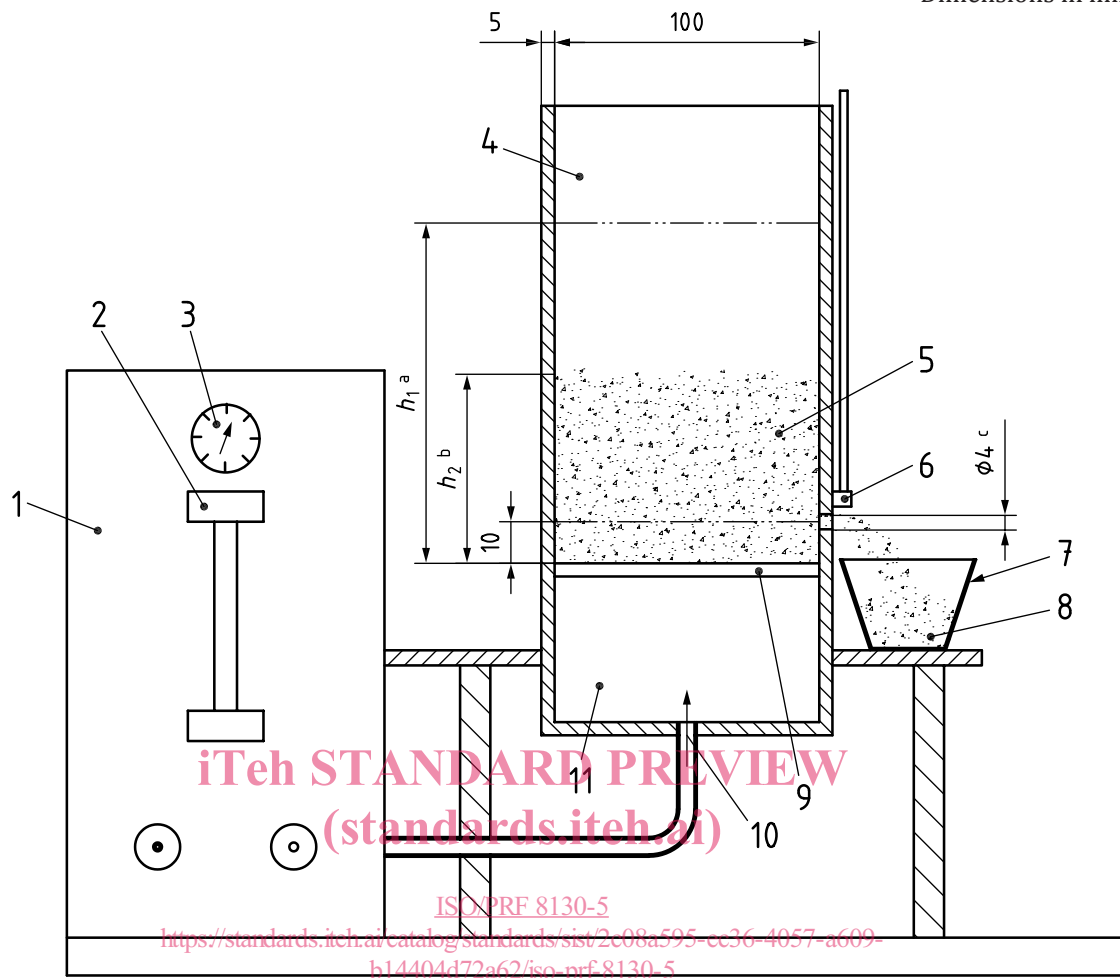
**Key**

- 1 air regulation unit B
- 2 flowmeter F
- 3 pressure gauge
- 4 vessel for fluidizing the powder (vessel A)
- 5 powder
- 6 stopper E
- 7 container C
- 8 powder (mass m)
- 9 porous bottom
- 10 air
- 11 removable unit G
- a Height of fluidized powder (h_1).
- b Height of powder "at rest" (h_2).
- c Circular opening D (diameter 4 mm).

Figure 1 — Example of an apparatus for the determination of flow properties

6 Sampling

Take a representative sample of the product to be tested as described in ISO 15528.

The quantity of the sample shall be sufficient for three determinations (see 8.3).

NOTE A sample of 1 kg can be recommended.

7 Procedure

7.1 Calibration of apparatus

Before measuring, calibrate the apparatus so that the air flow rate is 200 l/h.

7.2 Determination of flow properties

Carry out the determination in duplicate at (23 ± 2) °C, at a relative humidity of (50 ± 5) % and determine the atmospheric pressure.

Close opening D with stopper E and charge vessel A with (250 ± 10) g of the coating-powder sample.

Introduce clean dry air (5.2) through the porous bottom at a rate sufficient to achieve optimum fluidization of the powder, normally (200 ± 10) l/h. Note the air flow rate as measured on the flow meter F. To prevent “channelling” and “bubbling” during fluidizing, stir the powder with the spatula (5.6) until the height of the bed remains constant between stirrings.

Avoid static effects which could be introduced when the powder/air mixture is fluidizing in the vessel.

If optimum fluidization takes place at air flow rates outside the range (200 ± 10) l/h, use the appropriate air flow rate.

Direct comparison of the performance of powder fluidized at different air flow rates is not valid.

Measure the height h_1 of the fluidized bed to an accuracy of 2 mm. Switch off the air and allow the powder to settle (this can require 1 min to 2 min). Measure to within 2 mm the height h_2 of the powder at rest.

Fluidize the powder again at the same rate of air supply, assist fluidizing by stirring and wait until the fluidized powder bed has reached a constant level. Remove stopper E from opening D, starting the timer (5.3) at the same time, and collect the powder discharged through the opening during (30 ± 1) s. Close opening D with stopper E. Weigh the collected powder (m) to the nearest 0,1 g.

8 Expression of results

8.1 Calculate the fluidization factor, ϕ , using Formula (1):

$$\phi = \frac{h_1}{h_2} \quad (1)$$

where

h_2 is the height, in millimetres, of the powder at rest;

h_1 is the height, in millimetres, of the fluidized powder bed.

8.2 Calculate the powder flow rate R , in grams per second, using Formula (2):

$$R = \frac{m \cdot \phi}{t} \quad (2)$$

where

m is the mass, in grams, of powder collected in container C;

ϕ is the fluidization factor, as given in 8.1;

t is the time period, in seconds, needed for collecting the powder.

8.3 If the results differ by less than 5 % of the lower value, calculate the arithmetic mean of ϕ and R . If the difference between the two results exceeds 5 %, carry out a third determination and calculate the arithmetic mean of all three results. If the difference between the result of the third determination and those of the other determinations is greater than 5 %, state this and the individual results in the test report.

9 Precision

Precision data are currently not available.

10 Test report

The test report shall contain at least the following information:

- a) all details necessary to identify the product tested;
- b) a reference to this document, i.e. ISO 8130-5:2021;
- c) the temperature, humidity and pressure of the air in the test room;
- d) the air flow rate;
- e) an indication of irregularities in the fluidized bed (such as “channelling” or “bubbling”), if observed;
- f) the results of the test as indicated in 8.3;
- g) any deviation from the test method specified;
- h) any unusual features (anomalies) observed during the test;
- i) the date of the test.

iTeh STANDARD PREVIEW
(standards.iteh.ai)

ISO/PRF 8130-5

<https://standards.iteh.ai/catalog/standards/sist/2c08a595-ec36-4057-a609-b14404d72a62/iso-prf-8130-5>