

---

---

**Sintered metal materials, excluding  
hardmetals — Tensile test pieces**

*Matériaux en métal fritté, à l'exclusion des métaux-durs —  
Éprouvettes pour essai de traction*

iTeh STANDARD PREVIEW  
(standards.iteh.ai)

ISO 2740:2023

<https://standards.iteh.ai/catalog/standards/sist/5c68be53-ba16-4bc9-8c9d-ad4315571c0b/iso-2740-2023>



# iTeh STANDARD PREVIEW (standards.iteh.ai)

ISO 2740:2023

<https://standards.iteh.ai/catalog/standards/sist/5c68be53-ba16-4bc9-8c9d-ad4315571c0b/iso-2740-2023>



## **COPYRIGHT PROTECTED DOCUMENT**

© ISO 2023

All rights reserved. Unless otherwise specified, or required in the context of its implementation, no part of this publication may be reproduced or utilized otherwise in any form or by any means, electronic or mechanical, including photocopying, or posting on the internet or an intranet, without prior written permission. Permission can be requested from either ISO at the address below or ISO's member body in the country of the requester.

ISO copyright office  
CP 401 • Ch. de Blandonnet 8  
CH-1214 Vernier, Geneva  
Phone: +41 22 749 01 11  
Email: [copyright@iso.org](mailto:copyright@iso.org)  
Website: [www.iso.org](http://www.iso.org)

Published in Switzerland

# Contents

	Page
Foreword.....	iv
<b>1 Scope.....</b>	<b>1</b>
<b>2 Normative references.....</b>	<b>1</b>
<b>3 Terms and definitions.....</b>	<b>1</b>
<b>4 Method of testing.....</b>	<b>1</b>
<b>5 Manufacture of test pieces.....</b>	<b>1</b>
5.1 Pressed and sintered test pieces.....	1
5.2 Die specifications.....	2
<b>6 Metal injection-moulded test pieces.....</b>	<b>2</b>
<b>7 Machined test pieces.....</b>	<b>2</b>
<b>8 Identification of test pieces.....</b>	<b>3</b>

**iTeh STANDARD PREVIEW**  
(standards.iteh.ai)

ISO 2740:2023

<https://standards.iteh.ai/catalog/standards/sist/5c68be53-ba16-4bc9-8c9d-ad4315571c0b/iso-2740-2023>

## Foreword

ISO (the International Organization for Standardization) is a worldwide federation of national standards bodies (ISO member bodies). The work of preparing International Standards is normally carried out through ISO technical committees. Each member body interested in a subject for which a technical committee has been established has the right to be represented on that committee. International organizations, governmental and non-governmental, in liaison with ISO, also take part in the work. ISO collaborates closely with the International Electrotechnical Commission (IEC) on all matters of electrotechnical standardization.

The procedures used to develop this document and those intended for its further maintenance are described in the ISO/IEC Directives, Part 1. In particular, the different approval criteria needed for the different types of ISO document should be noted. This document was drafted in accordance with the editorial rules of the ISO/IEC Directives, Part 2 (see [www.iso.org/directives](http://www.iso.org/directives)).

ISO draws attention to the possibility that the implementation of this document may involve the use of (a) patent(s). ISO takes no position concerning the evidence, validity or applicability of any claimed patent rights in respect thereof. As of the date of publication of this document, ISO had not received notice of (a) patent(s) which may be required to implement this document. However, implementers are cautioned that this may not represent the latest information, which may be obtained from the patent database available at [www.iso.org/patents](http://www.iso.org/patents). ISO shall not be held responsible for identifying any or all such patent rights.

Any trade name used in this document is information given for the convenience of users and does not constitute an endorsement.

For an explanation of the voluntary nature of standards, the meaning of ISO specific terms and expressions related to conformity assessment, as well as information about ISO's adherence to the World Trade Organization (WTO) principles in the Technical Barriers to Trade (TBT), see [www.iso.org/iso/foreword.html](http://www.iso.org/iso/foreword.html).

This document was prepared by Technical Committee ISO/TC 119, *Powder metallurgy*, Subcommittee SC 3, *Sampling and testing methods for sintered metal materials (excluding hardmetals)*, in collaboration with the European Committee for Standardization (CEN) Technical Committee CEN/SS M11, *Powder metallurgy*, in accordance with the Agreement on technical cooperation between ISO and CEN (Vienna Agreement).

This sixth edition cancels and replaces the fifth edition (ISO 2740:2009), which has been technically revised.

The main changes are as follows:

- [Figure 3](#), specifically the die in it, has been updated;
- [Figure 4](#) (former Figure 3), table below, Type A1: Value  $R_1$  has been corrected to 12,5 mm;
- [Figure 4](#) (former Figure 3), table below, Type A2: Value  $R_1$  has been corrected to 11,5 mm;
- references to the revised ISO 6892-1 has been updated;
- in [5.2](#), measurement unit given to optional die exit taper and 4<sup>th</sup> paragraph has been inserted;
- a new test piece geometry has been added as [Figure 3](#).

Any feedback or questions on this document should be directed to the user's national standards body. A complete listing of these bodies can be found at [www.iso.org/members.html](http://www.iso.org/members.html).

# Sintered metal materials, excluding hardmetals — Tensile test pieces

## 1 Scope

This document is applicable to all sintered metals and alloys, excluding hardmetals.

This document specifies:

- the die cavity dimensions used for making tensile test pieces by pressing and sintering, and by metal injection moulding (MIM) and sintering;
- the dimensions of tensile test pieces machined from sintered and powder forged materials.

## 2 Normative references

The following documents are referred to in the text in such a way that some or all of their content constitutes requirements of this document. For dated references, only the edition cited applies. For undated references, the latest edition of the referenced document (including any amendments) applies.

ISO 6892-1, *Metallic materials — Tensile testing — Part 1: Method of test at room temperature*

ISO 7500-1, *Metallic materials — Calibration and verification of static uniaxial testing machines — Part 1: Tension/compression testing machines — Calibration and verification of the force-measuring system*

## 3 Terms and definitions

No terms and definitions are listed in this document.

ISO and IEC maintain terminology databases for use in standardization at the following addresses:

- ISO Online browsing platform: available at <https://www.iso.org/obp>
- IEC Electropedia: available at <https://www.electropedia.org/>

## 4 Method of testing

4.1 Test pieces shall be tested in accordance with ISO 6892-1, and the tensile test machine shall be calibrated to Class 1, in accordance with ISO 7500-1.

4.2 Data are to be reported for three or more test pieces.

## 5 Manufacture of test pieces

### 5.1 Pressed and sintered test pieces

The tensile test pieces shall have thicknesses from 5 mm to 6,5 mm. A thickness tolerance of 1,5 mm accommodates varying apparent densities in metal powders.

During testing, the thinner pieces have less grip slippage and are more likely to break near the centre of the gauge length.

If necessary for measuring elongation, marks may be lightly scribed 25 mm apart and symmetrically about the centre line, see [Figures 1 a\)](#), [2 a\)](#) and [3 a\)](#). Between the scribed marks, the thickness shall not vary by more than 0,04 mm. The gauge length shall be scribed in such a way that the tensile properties are not affected.

Because of the possibility of creating microlaminations in the corners of test pieces compacted under laboratory conditions, representative sintered test pieces shall be examined metallographically to show that there are no microlaminations longer than 0,25 mm.

## 5.2 Die specifications

The dimensions of the permitted die cavities are shown in [Figures 1 b\)](#), [2 b\)](#) and [3 b\)](#). The dies should preferably be of hardmetal and their surface finish shall be such as to allow compression of the test pieces under normal conditions. Dies may include a small exit taper to facilitate ejection and to avoid cracks or microlaminations in the test pieces, e.g. 0,01 mm per side. For repressing, a second die manufactured with cavity dimensions enlarged by up to 0,5 % may be used. The dies should be well supported with shrink rings, so as to keep the inner tensile stresses low. To reduce the incidence of cracks in the specimen, it is recommended to use top-punch hold-down during ejection.

The die in [Figure 1 b\)](#) is recommended for as-sintered test pieces. Gripping is readily accomplished by sliding the 20° wedge faces of the test piece into matching pockets machined in the grips. [Figure 1 a\)](#) shows the test piece.

The die in [Figure 2 b\)](#) is recommended for as-sintered test pieces. Serrated test pieces according to [Figure 2 a\)](#) are gripped on the raised serrations compacted on its gripping ends, to prevent slippage during testing. It is important for testing that the grips fit properly into the clevis. Alternatively, smooth test pieces are compacted without serrations and gripped on the flat faces.

The die in [Figure 3 b\)](#) can be beneficial for test pieces of high-strength materials such as sinter-hardened or heat-treated materials. Serrated test pieces are gripped on the serrations compacted on its gripping ends, to prevent slippage during testing. It is important for testing that the grips fit properly into the clevis. Alternatively, the test piece is compacted without serrations and gripped on the flat faces.

Test pieces made from the dies in [Figure 1 b\)](#) or [2 b\)](#) are recommended for materials to be tested in the as-sintered condition. When testing relatively brittle, heat-treated materials, the constraint of the test piece's sharp corners can result in tensile values that are lower than those obtained with machined tensile test pieces (see [Figure 6](#)) and a geometry according to [Figure 3 a\)](#) may be used.

## 6 Metal injection-moulded test pieces

[Figure 4](#) shows a larger diameter of the die cavity for metal injection moulding (MIM) tensile test pieces of type A. [Figure 5](#) shows a smaller die cavity for MIM tensile test pieces of type B. During testing, the through-holes are intended to surround hardened steel pins. The pins are gripped in a clevis and mounted on a testing machine in a self-aligning manner. The holes may optionally be drilled after sintering, rather than moulded with no draft permitted. These optional hole diameters should be: a diameter of 6,5 mm  $^{+0,25}_0$  mm for a large bar or a diameter of 4,77 mm  $^{+0,25}_0$  mm for a small bar, after sintering. The die dimensions assume about 17 % shrinkage during sintering, but variations in shrinkage are permitted. Either bar design may be used. Gauge marks may be scribed as noted in [5.1](#).

The gate, manufacturer's identification and ejector location are optional, but shall not be in the gauge length  $L_c$  and not in the gripping area.

## 7 Machined test pieces

**7.1** The dimensions of a machined button-head tensile test piece are shown in [Figure 6](#). This is conveniently machined from a standard 10 mm × 10 mm × 75 mm impact bar. The taper of 0,1 mm in

the nominal diameters, over the gauge length, generally results in fracture occurring within the gauge region, even for relatively brittle materials.

If a material is to be carburized after grinding, the surface pores in the gauge region shall be left open to allow carburizing gases to enter. Final polishing shall be in the longitudinal direction (no circumferential scratch lines shall be visible).

The test piece is gripped by a split collet, closely surrounding the 20° tapered region. During testing, the test piece is supported on the same taper. The test piece may have a 25 mm gauge length lightly scribed as in [5.1](#).

This test piece, together with test pieces according to [Figure 3 a\)](#), is primarily recommended for testing materials in the heat-treated condition, where elongations at fracture may be < 0,5 % in 25 mm. This test piece is recommended for use when the volume fraction of martensite is > 20 %, regardless of whether the test piece is as-sintered or heat-treated. Some work-hardening occurs during machining, and if the test piece is tested in the sintered and machined condition, the work-hardening can lower elongation and raise yield strength. This is particularly true for stainless steels.

During austenitizing and oil quenching, the usual sintered alloy steels may not fully harden to the centre of the machined test pieces. Such test pieces may be further qualified in the report, by indicating the hardness from the surface to the core.

**7.2** Other cylindrical machined test pieces are possible and should conform to ISO 6892-1.

When the diameter of the useful part of the test pieces is less than 4 mm, its value shall be stated together with the fact that the results of the test may not be comparable with those obtained from test pieces of larger diameters.

For sintered products, it is recommended that a test piece having two shoulders at each end be used. The radius of the inner shoulder shall be between 1,5 mm and 2,5 mm (see [Figure 6](#)).

## 8 Identification of test pieces

For the identification of test pieces, the following shall be stated:

- a) a reference to this document, i.e. ISO 2740;
- b) type of material;
- c) density of test piece;
- d) dimensions of test piece (thickness);
- e) when pressed and sintered test pieces are made according to [5.1](#), the nature of any finishing treatment and also, preferably, the material and the surface finish of the compacting tool;
- f) form of test piece, i.e. figure number of this document;
- g) die material, i.e. tool steel or hardmetal/carbide;
- h) whether as-sintered or heat-treated;
- i) hardness of test piece according to the heat treatment.

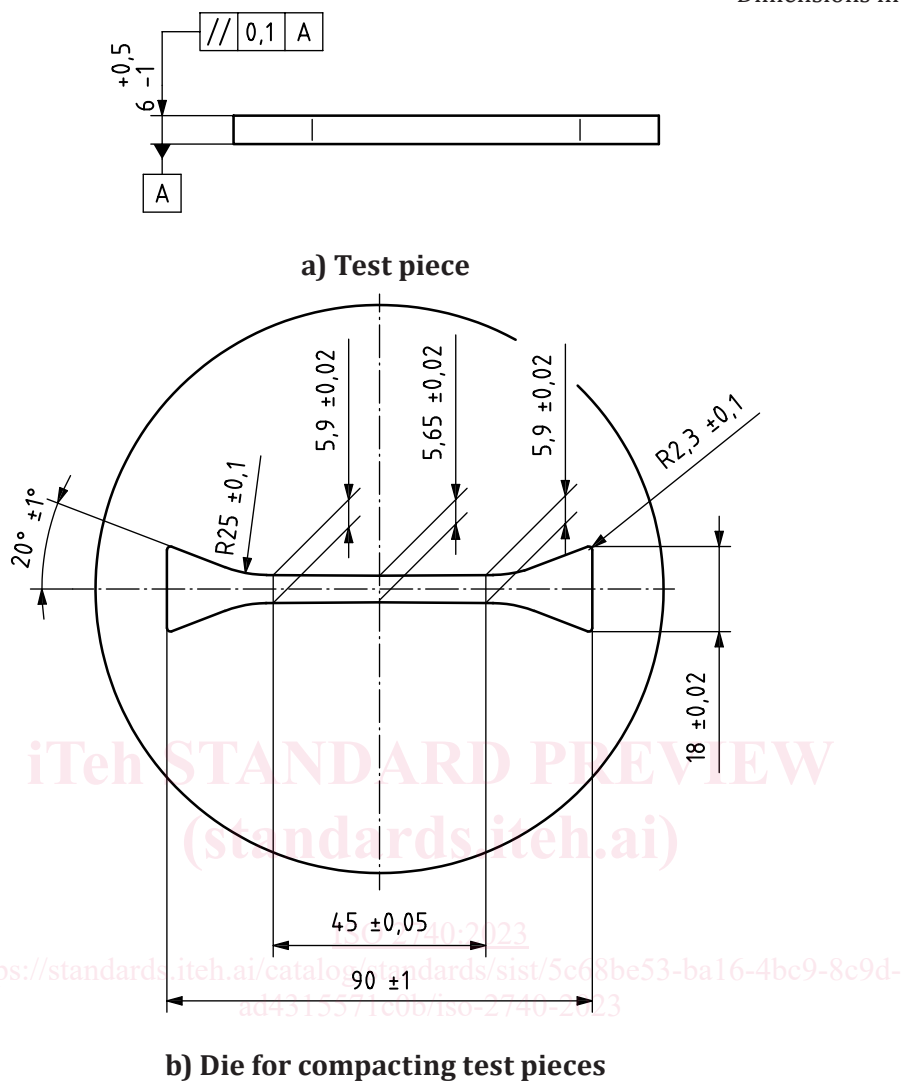
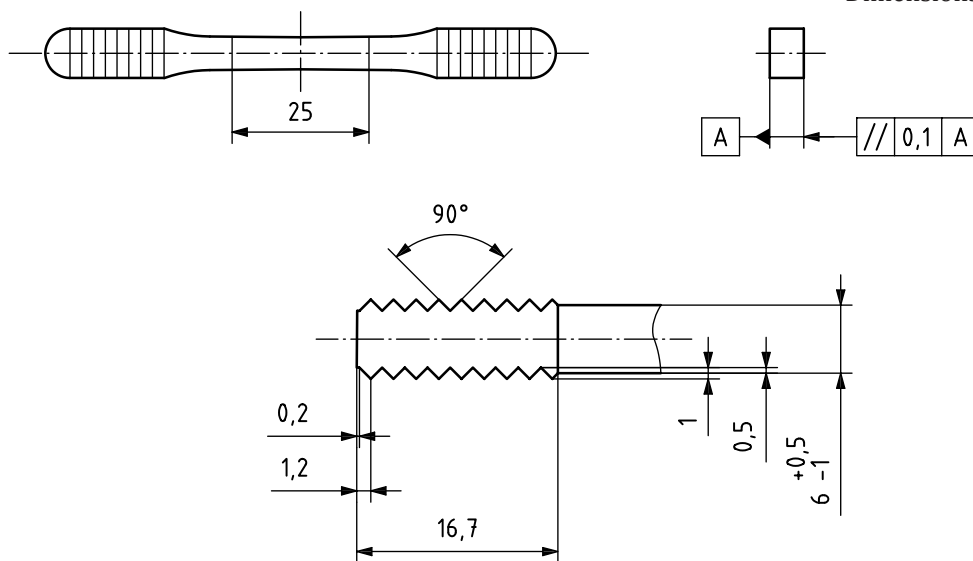

Figure 1 — Test piece and die for tensile testing — Form fit grips



Dimensions in millimetres



a) Test piece

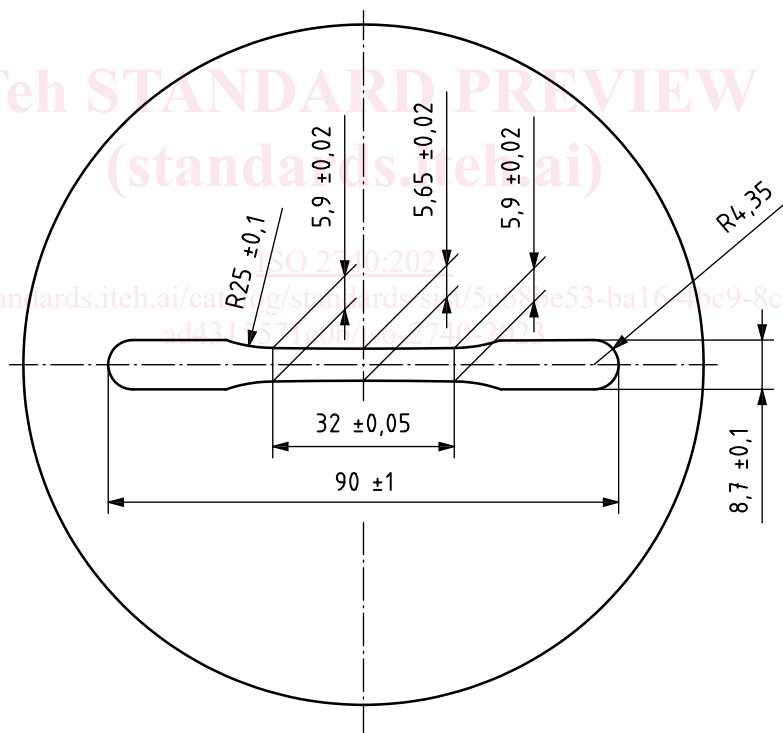

b) Die for compacting test pieces

Figure 2 — Test piece and die for tensile testing — Serrated or smooth grips

Dimensions in millimetres

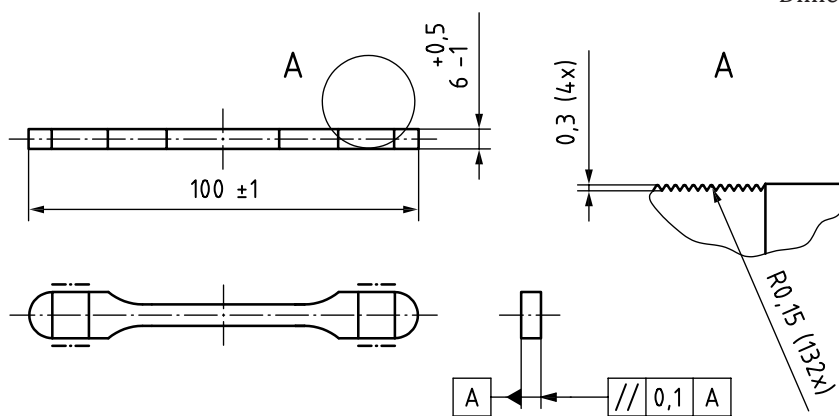

a) Test piece

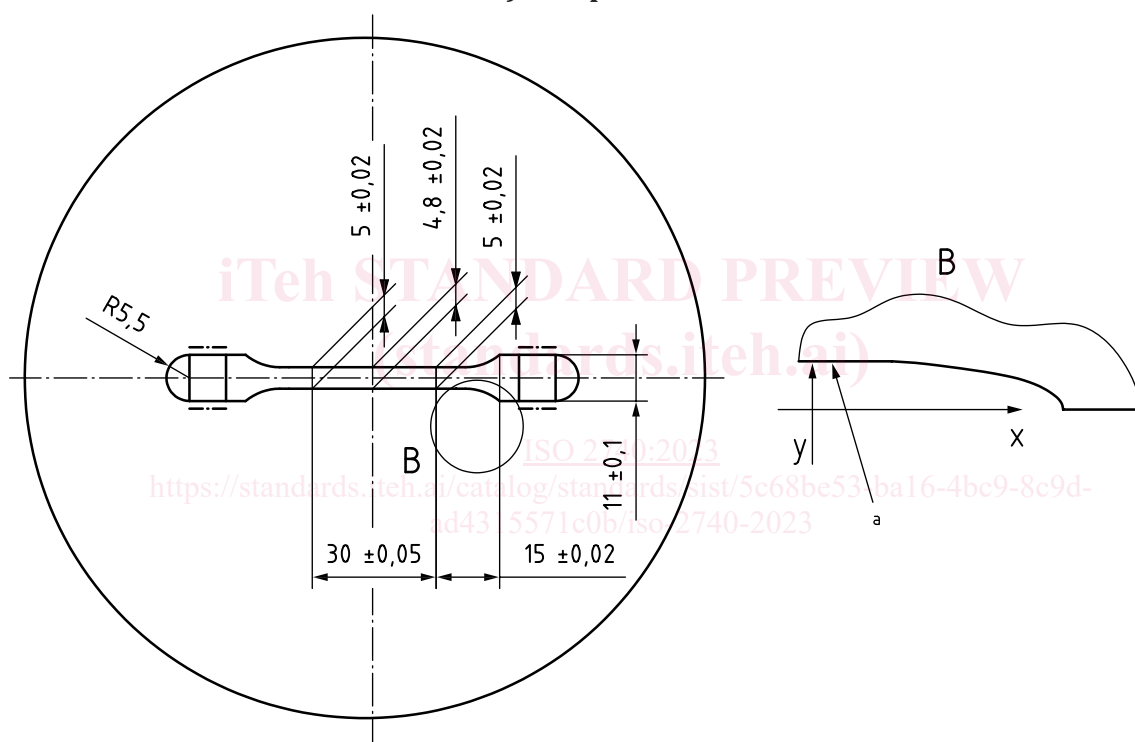

b) Die for compacting test pieces

<sup>a</sup> Ellipse  $y = 3\sqrt{1 - (x/15)^2}$ .

Figure 3 — Test piece and die for tensile testing — Serrated or smooth grips