



Designation: E998 – 12

Standard Test Method for Structural Performance of Glass in Windows, Curtain Walls, and Doors Under the Influence of Uniform Static Loads by Nondestructive Method¹

This standard is issued under the fixed designation E998; the number immediately following the designation indicates the year of original adoption or, in the case of revision, the year of last revision. A number in parentheses indicates the year of last reapproval. A superscript epsilon (ϵ) indicates an editorial change since the last revision or reapproval.

1. Scope

1.1 This test method is a nondestructive test procedure to establish the nature of stresses induced in glass subjected to uniform static loads. A procedure is provided for using this stress information to estimate the probability of breakage of the glass.

1.2 This test method is applicable to glass of various degrees of temper; for example, annealed, heat-strengthened, fully tempered, laminated, insulating, and combinations thereof.

1.3 This test method describes a process of applying specific test loads to glass. The test may be conducted using the standard test frame specified herein or a test frame of the user's design.

1.4 The values stated in SI units are to be regarded as standard. The values given in parentheses are mathematical conversions to inch-pound units that are provided for information only and are not considered standard.

1.5 *This standard does not purport to address all of the safety problems, if any, associated with its use. It is the responsibility of the user of this standard to establish appropriate safety and health practices and determine the applicability of regulatory limitations prior to use.* For specific precautionary statements see Section 7.

2. Referenced Documents

- 2.1 *ASTM Standards*:²
[E631 Terminology of Building Constructions](#)

3. Terminology

3.1 Definitions:

¹ This test method is under the jurisdiction of ASTM Committee E06 on Performance of Buildings and is the direct responsibility of Subcommittee E06.52 on Glass Use in Buildings.

Current edition approved April 1, 2012. Published May 2012. Originally approved in 1984. Last previous edition approved in 2011 as E998 – 11. DOI: 10.1520/E0998-12.

² For referenced ASTM standards, visit the ASTM website, www.astm.org, or contact ASTM Customer Service at service@astm.org. For *Annual Book of ASTM Standards* volume information, refer to the standard's Document Summary page on the ASTM website.

3.1.1 For definitions of general terms related to building construction used in this test method refer to Terminology E631.

3.2 Definitions of Terms Specific to This Standard:

3.2.1 *aspect ratio*—a ratio of long side to short side of the glass lite.

3.2.2 *average breaking stress (ABS)*—the average maximum principal tensile stress (MPTS) at failure, representative of the glass under test. The ABS is dependent on a number of factors including geometry, time history of load, surface condition, and so forth. Glasses with residual surface stresses, such as heat-strengthened or fully tempered, must have their residual stresses added to the state of stress at the specified load. As defined for use in the standard, the ABS is for annealed glass.

3.2.3 *coefficient of variation*—the ratio (decimal fraction) of the standard deviation of the maximum principal tensile stress (MPTS) at failure to the ABS.

3.2.4 *equivalent design load*—a magnitude of a uniform load and the load duration selected by the specifying authority to represent design loads.

3.2.5 *glass specimen*—the glass to be tested, for example, a single lite, an insulating glass unit, laminated glass, and so forth (does not include test frame).

3.2.6 *maximum principal tensile stress (MPTS)*—a maximum calculated tensile stress based on strain gage measurements.

3.2.7 *negative load*—a load that results in the indoor side of a glass specimen being the high-pressure side.

3.2.8 *permanent set of test frame*—a load-induced permanent displacement from an original position of the test frame.

3.2.9 *positive load*—a load that results in the outdoor side of a glass specimen being the high-pressure side.

3.2.10 *probability of breakage*—the probability that a glass specimen breaks when tested at a given equivalent design load. General industry practice to express probability as lites per 1000 lites.

3.2.11 *residual stress*—an initial, state of stress on unloaded, unglazed glass resulting from the manufacturing process (heat-strengthening, tempering).

3.2.12 *specifying authority*—the professional or professionals responsible for determining and furnishing the information required to perform this test method as described in Section 10.

4. Summary of Test Method

4.1 This test method consists of:

4.1.1 Glazing the test specimen into a test frame that is mounted on or against a test chamber.

4.1.2 Supplying or exhausting air from the chamber at a rate required to maintain a test-pressure difference across the test specimen.

4.1.3 Measuring and observing deflections, deformations, specimen strains, and the nature of any failures.

4.1.4 Recording the results in an orderly manner.

4.2 Methods of loading to nondestructive levels are provided.

4.3 Test data are used to predict glass structural performance characteristics.

5. Significance and Use

5.1 This test method is a standard procedure to determine a stress pattern and estimate a probability of breakage of glass tested under uniform static loads.

5.2 Loads on glass in windows, curtain walls, and doors may vary greatly in magnitude, direction, and duration. An understanding of wind loads on the building is required for selection of test loads and interpretation of results with respect to expected exposure at a particular site.

5.3 The strength of glass varies with many different factors including surface condition, load duration, geometry, relative humidity, and temperature (1, 2, 3, 4).³

5.4 A thorough understanding of the variations of the strength of glass and the nature of loading is required to interpret results of this test method.

5.5 The proper use of this test method requires a knowledge of the principles of pressure, deflection and strain measurement, stress/strain relationships, and statistical estimating techniques.

6. Apparatus

6.1 The description of apparatus is general in nature. Any equipment capable of performing the test procedure within the allowable tolerances shall be permitted.

6.2 *Major Components:*

6.2.1 *Test Frame*, in which glass specimens are mounted for testing. The test frame shall provide either standardized support conditions or specified support conditions. Specifications of standardized support conditions are presented in Annex A1.

6.2.2 *Test Chamber*, sealed, with an opening in which or against which the test frame shall be installed. At least one static pressure tap shall be provided to measure the test chamber pressure and shall be so located that the reading is minimally affected by the velocity of the air supply to or from

the test chamber or any other air movement. The air supply opening into the test chamber shall be arranged so that the air does not impinge directly on the glass specimen with any significant velocity. A means of access into the test chamber shall be permitted to facilitate adjustments and observations after the specimen has been installed.

6.2.3 *Air System*, a controllable blower, compressed air supply, exhaust system, reversible blower or other device designed to apply the equivalent design load to the glass specimen with required control.

6.2.4 *Pressure Measuring Apparatus*, to record continuously the test chamber pressure within an accuracy of $\pm 2\%$.

6.2.5 *Deflection-Measuring System*, for measuring deflections within an accuracy of ± 0.25 mm (0.01 in.).

6.2.5.1 The deflection indicator shall be mounted so that deflection of the test chamber or test frame is not included in the deflection gage reading. Provisions shall be made to ensure that readings can be made from a safe location.

6.2.6 *Strain Gage Measurements*—Appendix X1 describes apparatus and techniques required for proper strain measurements on glass.

6.2.7 *Temperature Measuring Apparatus*, to measure the ambient temperature within an accuracy of $\pm 0.6^\circ\text{C}$ (1°F).

6.2.8 *Relative Humidity Measuring Apparatus*, to measure the relative humidity within an accuracy of $\pm 2\%$.

7. Safety Precautions

7.1 Proper precautions to protect observers in the event of glass specimen failure shall be observed. At the pressures used in this test method, considerable energy and hazard are involved. In cases of breakage, the hazard to personnel is less with an exhaust system, as the specimen will tend to blow into rather than out of the test chamber. No personnel shall be permitted in such chambers during tests. All reasonable precautions shall be exercised during conduct of the test.

8. Sampling and Glass Specimens

8.1 Surface condition, cutting, fabrication, and packaging of the glass specimens to be tested shall be representative of the glass whose strength is to be evaluated.

8.2 All glass specimens shall be visually inspected for edge or surface irregularities prior to testing, and all questionable glass specimens shall not be tested. All questionable glass specimens shall be reported to the specifying authority.

8.3 Glass specimens shall be handled carefully at all times because the strength of glass is influenced by its surface and edge conditions.

9. Calibration

9.1 Pressure-measuring systems, deflection-measuring devices, and strain gages shall be routinely checked. If calibration is required, the manufacturer's recommendations or good engineering practice shall be followed.

10. Required Information

10.1 The specifying authority shall provide the magnitude of the equivalent design load (positive or negative) and the allowable probability of breakage for the glass specimens.

³ The boldface numbers in parentheses refer to the references listed at the end of this test method.

10.2 The specifying authority shall state whether the glass specimens shall be glazed in a standard test frame or in a test frame designed to simulate a specific glazing system. If the test frame is to simulate a specific glazing system, complete glazing details and support conditions shall be provided by the specifying authority.

11. Procedure

11.1 Measure and record ambient temperature and the relative humidity.

11.2 Install strain gages to the low pressure side of the glass specimen according to procedures in [Annex A2](#).

11.3 Install glass specimens in the test frame in accordance with recommendations in [Annex A1](#) for standard support conditions or as specified for a specific glazing system by the manufacturer.

11.4 Record reference strain reading at no-load conditions.

11.5 Load specimen to low level pressure, 20 % of design load for 1 min. Release load. Allow 3 to 5-min gage and restoration time.

11.6 Apply one-half of the specified design load to the glass specimen. Take initial set of pressure, deflection, and strain readings at one-half of design load. Reduce the test pressure to 0, and vent the test chamber for a period of 3 to 5 min before pressure-measuring apparatus is adjusted to zero.

11.6.1 If air leakage around the test specimen is excessive, tape shall be permitted to be used to cover any cracks and joints through which the leakage is occurring. Tape shall not be used when there is a probability that it may significantly restrict differential movement between the glass and test frame.

11.7 Apply load to the glass specimen in increments of 20 % of specified design load, recording strain gage readings at each increment. Maintain the load at each increment of design load until all strain gage readings are taken. For each increment, the load should not be applied for a period under 1 min or longer than 5 min in duration. Continuous load-time records shall be kept for the duration of the loading.

11.8 If the specimen breaks prior to reaching the specified design load, check for permanent set of the test frame and chamber damage before testing another specimen.

12. Report

12.1 The report shall include the following information:

12.1.1 Date of the test, the date of the report, the ambient temperature, and the relative humidity.

12.1.2 Identification of the glass specimens (manufacturer, source of supply, dimensions, both nominal and measured, manufacturer's designation, materials, and other pertinent information).

12.1.3 Detailed drawings of the glass specimen, test frame, test chamber, a complete description of pressure-measuring apparatus, all other instrumentation, and a statement that the test was conducted using a standard test frame or a test frame of the user's design.

12.1.4 Records of pressure differences exerted across each glass specimen during the test with each specimen being properly identified.

12.1.5 Probability of breakage (Z_o) as calculated in Section [13](#) (Analysis).

12.1.6 Identification or description of any applicable specification.

12.1.7 A statement that the tests were conducted in accordance with this test method, or a full description of any deviations.

13. Analysis

13.1 An analysis of the structural performance of the glass specimen(s) shall be made.

13.2 *Procedure A:*

13.2.1 Calculate maximum principal stress from strain gage data (see [Appendix X1](#)).

13.2.2 *Average Breaking Strength of Glass (ABS)*—The *ABS* is a necessary value for use in analyzing the structural performance of the glass. For new glass, the *ABS* shall be obtained from the appropriate glass manufacturer for the glass in question. For glass that has been in service, or treated by others (weathered, altered, damaged, scratched, or mechanically altered) engineering judgement shall be used to determine the *ABS*. The area of the glass lite and the duration of imposed load affect the *ABS*. The magnitude of the load duration effect can be roughly approximated by using [Eq X1.1](#) in [Appendix X1](#).

13.3 *Probability of Breakage*—Once glass *ABS* is established (Procedure A), the normal probability distribution function is used to predict probability of breakage. The probability of breakage for glass is calculated as follows:

$$\text{Area} = Pr(Z \geq z_o) \quad (1)$$

$$Z_o = \frac{X - ABS}{CV \times ABS}$$

where:

X = maximum glass tension stress resulting from specified or test wind load, MPa (psi),

ABS = glass *ABS*, MPa (psi),

CV = coefficient of variation, 0.22 for annealed glass, and

Z_o = standard normal variable (see [Table X1.2](#)).

Using the standard normal distribution table, the area to the right of the Z_o indicates the probability of breakage at that level (see [Table X1.2](#)).

NOTE 1—Glasses with residual surface stresses, such as heat-strengthened or fully tempered, shall have their residual stresses added to the state of stress at the specified load. For example, the state of stress of a heat-strengthened glass surface is 35 MPa (5000 psi) at design load, if the glass has a residual compressive stress on the surface of 24 MPa (−3500 psi), the resulting tensile stress component is 10 MPa (1500 psi) at design load.

NOTE 2—Load/stress relationships for large deflections in glass may be adequately defined by finite-element computer techniques. The values obtained by this technique will be useful for defining probability of breakage estimates at various load/glass stress combinations.

14. Precision and Bias

14.1 No statement is made about either the precision or the bias of this test method for measuring the structural performance of glass since the result merely states whether the probability of breakage of the glass specimens is significantly greater than the specified probability of breakage or not.

15. Keywords

15.1 annealed glass; curtain walls; doors; flat glass; fully tempered glass; glass performance; heat-strengthened glass; nondestructive testing; performance testing; strain gages; structural performance; uniform static loads; windows

ANNEXES

(Mandatory Information)

A1. STANDARD GLASS TEST FRAME

A1.1 Introduction

A1.1.1 The standard test frame shall be designed to support a rectangular glass specimen in a vertical plane and expose it to a positive (inward-acting) load. The test frame shall consist of two primary systems: a structural support system and a glazing system. The structural support system shall be designed to resist applied loads with limited deflections and provide an interface between the test chamber and the glazing system. The glazing system shall be designed to limit lateral displacements of the glass specimen edges while minimizing rotational and in-plane restraints of the glass specimen edges. This annex presents pertinent details relating to the design and construction of a standard test frame.

A1.2 Structural Support System

A1.2.1 The structural support system shall consist of four main structural members arranged as shown in Fig. A1.1. The inside rectangular dimensions, *a* and *b*, of the support system

shall be found by subtracting 25 mm (1 in.) from the corresponding dimensions of the glass specimens. These dimensions shall be maintained within a tolerance of ± 1.6 mm ($1/16$ in.).

A1.2.2 The structural members shall be selected from available American Standard channels with flange widths greater than or equal to 44 mm ($1\frac{3}{4}$ in.). The structural members are to be designed to withstand the appropriate proof load without permanent deformations. In addition, the structural members shall be designed to meet the following deflection criteria:

A1.2.2.1 The maximum lateral deflection (referenced to glass specimen) of the structural members shall not exceed $L/750$ where *L* is the length of the shorter side of the glass specimen,

A1.2.2.2 The maximum rotation of the structural members shall not exceed 1°, and

A1.2.2.3 The maximum in-plane deflection (referenced to the glass specimen) of the structural members shall not exceed $L/2000$.

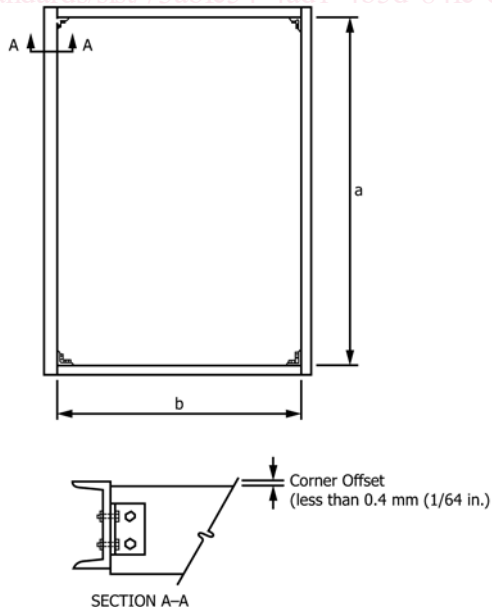

FIG. A1.1 Structural Support System

A1.2.3 The corner connections of the support system shall be designed using angle braces and bolts to minimize racking or twisting during testing.

A1.2.4 In addition to the above criteria, the following fabrication tolerances shall be met:

A1.2.4.1 The maximum out-of-plane offset at the corners shall not exceed 0.4 mm ($1/64$ in.) (see Fig. A1.1),

A1.2.4.2 The maximum planar variation of the outside edges of the structural members shall not exceed 1.6 mm ($1/16$ in.).

A1.2.4.3 The maximum difference in the measured diagonals of the interior rectangular opening shall not exceed 3 mm ($1/8$ in.), and

A1.2.4.4 The depth of the structural members shall be sufficient to allow unimpaired lateral displacements of the glass specimens during the test.

A1.2.5 Finally, holes shall be provided as required in the flanges of the structural members for fasteners used to retain the glass specimen.

A1.3 Glazing System

A1.3.1 The glazing system, which attaches to the vertical structural support system, shall consist of the following major components (see Fig. A1.2, Fig. A1.3 and Fig. A1.4):

- A1.3.1.1 Inside and outside glazing stops,
- A1.3.1.2 Aluminum spacers,
- A1.3.1.3 Inside and outside neoprene gaskets,
- A1.3.1.4 Structural fasteners, and
- A1.3.1.5 Neoprene setting blocks.

A1.3.2 The glass specimen shall rest on two neoprene setting blocks (85 ± 5 shore A durometer) as shown in Fig. A1.4. The glass specimen shall be laterally supported around its perimeter with neoprene gaskets (65 ± 5 Shore A durometer). The glass specimen shall be centered within the glazing system to a tolerance of ± 1.5 mm ($1/16$ in.). A minimal clamping force (700 to 1750 N/m (4 to 10 lbf/in.)) shall be applied to the edge of the glass specimen. The clamping force shall be determined for various glass thicknesses and shims by

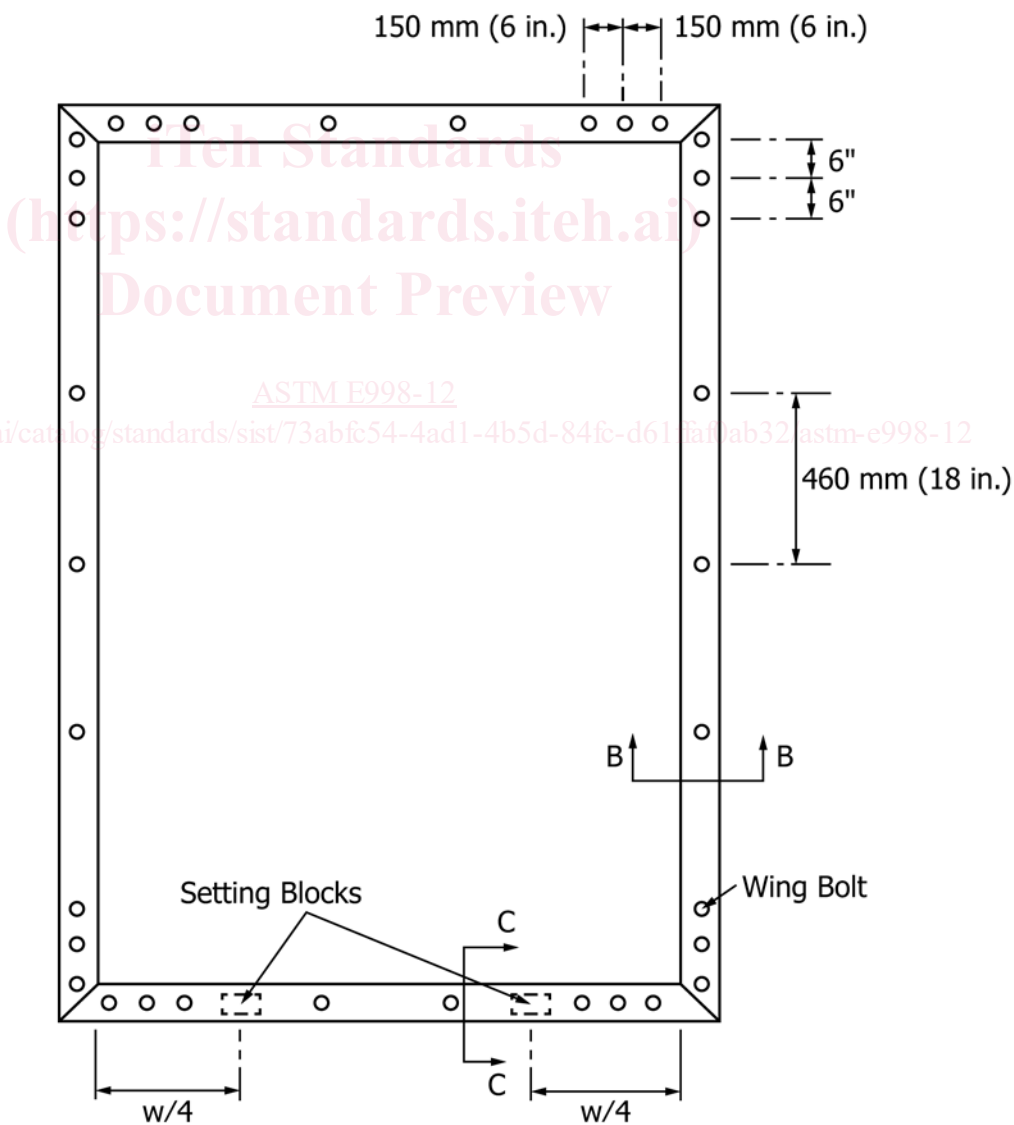

FIG. A1.2 Standard Glazing System

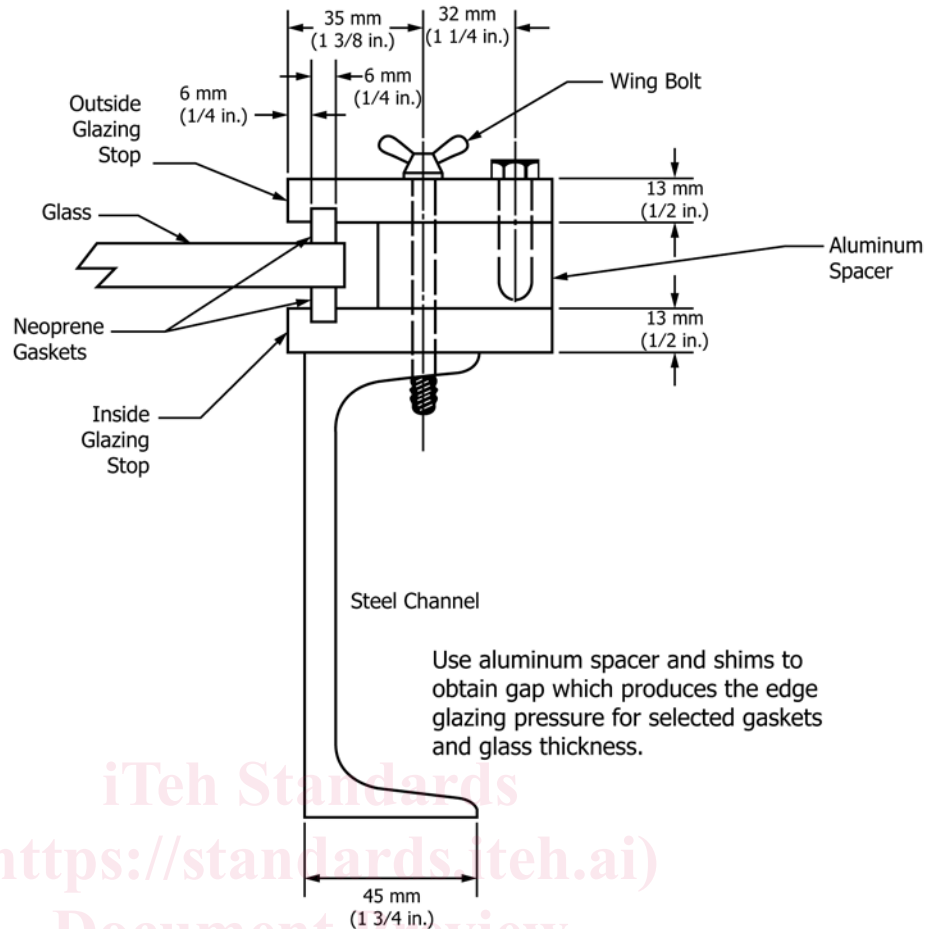

FIG. A1.3 Section B-B of Standard Glazing System

ASTM E998-12

using a load cell or force gage in the glazing pocket when the wing bolts are firmly tightened.

A1.3.3 The glazing stops shall be fabricated using 13 by 76-mm (1/2 by 3-in.) aluminum bar stock in sections no shorter than 610 mm (24 in.) or the smaller rectangular glass specimen dimension. A 3.2 by 9.5-mm (1/8 by 3/8-in.) rectangular slot shall be machined in the glazing stops as shown in Fig. A1.3. At each corner the glazing stops shall be mitered and fitted as shown in Fig. A1.2.

A1.3.4 The inside glazing stop shall be fastened to the top flange of the structural support members using 6.4-mm (1/4-in.) diameter bolts. These bolts shall pass through a clear hole in the channel flange into a threaded hole in the inside glazing stop. These bolts shall not extend above the surface of the inside glazing stop. These bolts shall be spaced no further than 610 mm (24 in.) apart with no fewer than two bolts per glazing stop section.

A1.3.5 The outside glazing stop shall be secured to the support system using 9.5-mm (3/8-in.) diameter wing bolts. These bolts shall pass through the outside glazing stop, through the aluminum spacer, and into a threaded hole in the support channels. In the corner areas there shall be three wing bolts spaced at 150-mm (6-in.) intervals as shown in Fig. A1.2.

Between these corner bolts, the bolts shall be spaced no further than 457 mm (18 in.) apart with a minimum of two bolts per glazing stop section.

A1.3.6 The rectangular aluminum spacers shall be fabricated using 19-mm (3/4-in.) wide aluminum bar stock. The width of the aluminum spacer shall be sufficient to extend from the outer edge of the Standard Glazing System frame at least 6 mm (1/2 in.) past the shaft of the wing bolt as shown in Fig. A1.3. Clearance holes shall be drilled into the aluminum spacer to allow the wing bolts to pass through. The thickness of the aluminum spacer shall be determined such that the glass edge pressure complies with the requirements of A1.3.2. The depth of the spacers shall be equal to the thickness of the glass plus 9.5 mm (3/8 in.). This dimension shall be maintained within a tolerance of ±0.8 mm (1/32 in.). The lengths of the spacers shall correspond to the lengths of matching outside glazing stop sections. In corner areas the spacers shall extend no further than 25.4 mm (1 in.) past the corner of the installed glass specimen. The spacers shall be fastened to the outside glazing stops using 6-mm (1/4-in.) diameter bolts. These bolts pass through the outside glazing stop into a threaded hole in the spacer. These bolts shall be spaced no further than 610 mm (24 in.) apart with no fewer than 2 bolts per glazing stop section.