



Designation: E1012 – 12

Standard Practice for Verification of Testing Frame and Specimen Alignment Under Tensile and Compressive Axial Force Application¹

This standard is issued under the fixed designation E1012; the number immediately following the designation indicates the year of original adoption or, in the case of revision, the year of last revision. A number in parentheses indicates the year of last reapproval. A superscript epsilon (ϵ) indicates an editorial change since the last revision or reapproval.

1. Scope*

1.1 Included in this practice are methods covering the determination of the amount of bending that occurs during the application of tensile and compressive forces to notched and unnotched test specimens during routine testing in the elastic range. These methods are particularly applicable to the force levels normally used for tension testing, creep testing, and uniaxial fatigue testing. The principal objective of this practice is to assess the amount of bending exerted upon a test specimen by the ordinary components assembled into a materials testing machine, during routine tests.

2. Referenced Documents

2.1 ASTM Standards:²

- E6 Terminology Relating to Methods of Mechanical Testing
- E8 Test Methods for Tension Testing of Metallic Materials
- E9 Test Methods of Compression Testing of Metallic Materials at Room Temperature
- E21 Test Methods for Elevated Temperature Tension Tests of Metallic Materials
- E83 Practice for Verification and Classification of Extensometer Systems
- E251 Test Methods for Performance Characteristics of Metallic Bonded Resistance Strain Gauges
- E466 Practice for Conducting Force Controlled Constant Amplitude Axial Fatigue Tests of Metallic Materials
- E606 Practice for Strain-Controlled Fatigue Testing
- E1237 Guide for Installing Bonded Resistance Strain Gages

2.2 Other Documents:

- VAMAS Guide 42 A Procedure for the Measurement of Machine Alignment in Axial Testing

¹ This practice is under the jurisdiction of ASTM Committee E28 on Mechanical Testing and is the direct responsibility of Subcommittee E28.01 on Calibration of Mechanical Testing Machines and Apparatus.

Current edition approved June 1, 2012. Published June 2010. Originally approved in 1989. Last previous edition approved in 2005 as E1012 – 05. DOI: 10.1520/E1012-12.

² For referenced ASTM standards, visit the ASTM website, www.astm.org, or contact ASTM Customer Service at service@astm.org. For *Annual Book of ASTM Standards* volume information, refer to the standard's Document Summary page on the ASTM website.

3. Terminology

3.1 Definitions of Terms Common to Mechanical Testing:

3.1.1 For definitions of terms used in this practice that are common to mechanical testing of materials, see Terminology E6.

3.1.2 *alignment*, n —the condition of a testing machine that influences the introduction of bending moments into a specimen (or alignment transducer) during the application of tensile or compressive forces.

3.1.3 *eccentricity* [L], n —the distance between the line of action of the applied force and the axis of symmetry of the specimen in a plane perpendicular to the longitudinal axis of the specimen.

3.1.4 *reduced section* [L], n —section in the central portion of the specimen which has a cross section smaller than the gripped ends.

3.2 Definitions of Terms Specific to This Standard:

3.2.1 *axial strain*, a , n —the average of the longitudinal strains measured by strain gages at the surface on opposite sides of the longitudinal axis of symmetry of the alignment transducer by multiple strain-sensing devices located at the same longitudinal position.

3.2.1.1 *Discussion*—This definition is only applicable to this standard. The term is used in other contexts elsewhere in mechanical testing.

3.2.2 *bending strain*, b , n —the difference between the strain at the surface and the axial strain (see Fig. 1).

3.2.2.1 *Discussion*—in general, the bending strain varies from point to point around and along the reduced section of the specimen. Bending strain is calculated as shown in Section 10.

3.2.3 *component* (also known as *force application component*), n —any of the parts used in the attachment of the load cell or grips to the testing frame, as well as any part, including the grips used in the application of force to the strain-gaged alignment transducer or the test specimen.

3.2.4 *grips*, n —that part of the force application components that directly attach to the strain-gage alignment transducer or the test specimen.

3.2.5 *microstrain*, n —strain expressed in micro-units per unit, such as micrometers/meter or microinches/in.

*A Summary of Changes section appears at the end of this standard

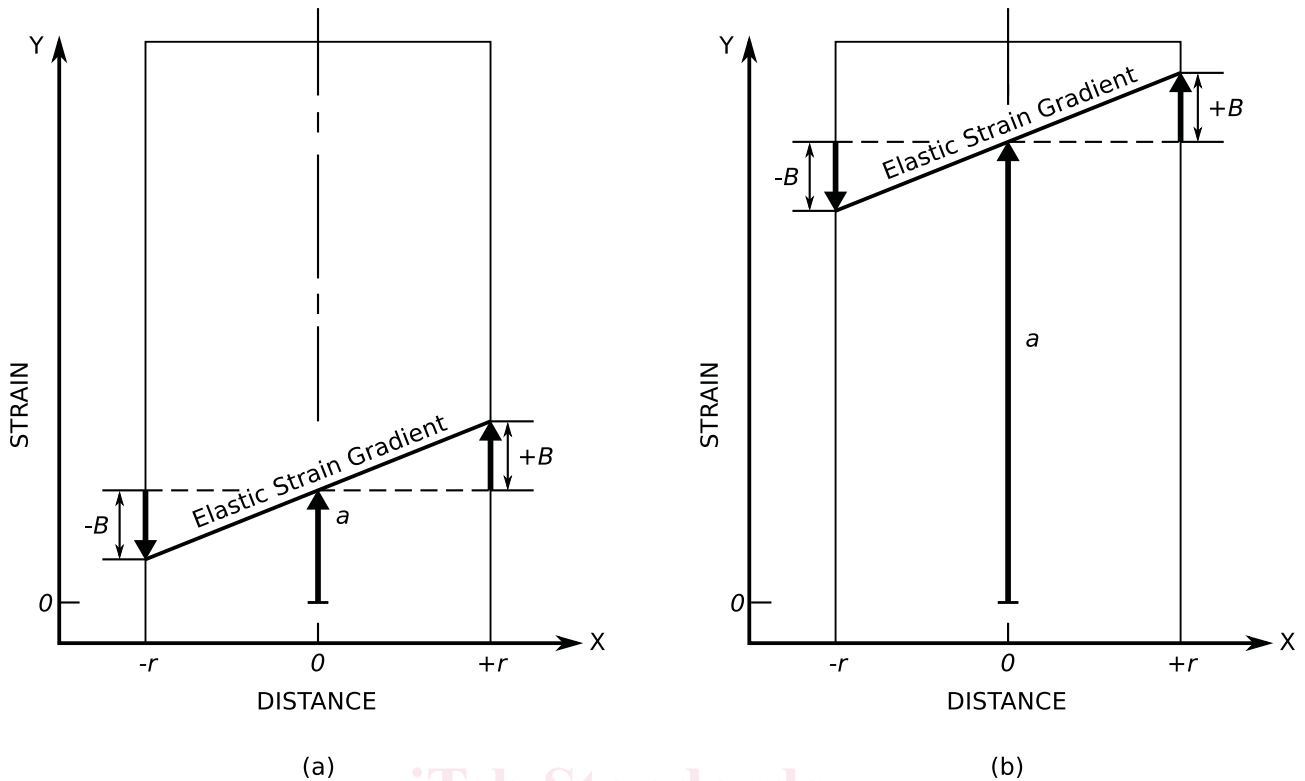

NOTE 1—A bending strain, $\pm B$, is superimposed on the axial strain, a , for low-axial strain (or stress) in (a) and high-axial strain (or stress) in (b). For the same bending strain $\pm B$, a high-percent bending is indicated in (a) and a low-percent bending is indicated in (b).

FIG. 1 Schematic Representations of Bending Strains (or Stresses) That May Accompany Uniaxial Loading

3.2.6 notched section [L], n —the section perpendicular to the longitudinal axis of symmetry of the specimen where the cross-sectional area is intentionally at a minimum value in order to serve as a stress raiser.

3.2.7 percent bending, PB , (also known as percent bending strain), n —the ratio of the bending strain to the axial strain expressed as a percentage.

3.2.8 strain-gaged alignment transducer, n —the transducer used to determine the state of bending and the percent bending of a testing frame.

3.2.9 Type 1 alignment, n —the condition of a testing machine typically used for static or quasi-static testing including the non-rigid components and the positioning of the specimen within the grips which can introduce bending moments into the strain-gaged alignment transducer or test specimen during force application.

3.2.10 Type 2 alignment, n —the condition of a testing machine typically used for dynamic testing and all rigid parts of the load train which can introduce bending moments into the strain-gaged alignment transducer or test specimen force application.

4. Significance and Use

4.1 It has been shown that bending stresses that inadvertently occur due to misalignment between the applied force and the specimen axes during the application of tensile and compressive forces can affect the test results. In recognition of

this effect, some test methods include a statement limiting the misalignment that is permitted. The purpose of this practice is to provide a reference for test methods and practices that require the application of tensile or compressive forces under conditions where alignment is important. The objective is to implement the use of common terminology and methods for verification of alignment of testing machines, associated components and test specimens.

4.2 Alignment verification intervals when required are specified in the methods or practices that require the alignment verification. Certain types of testing can provide an indication of the current alignment condition of a testing frame with each specimen tested. If a test method requires alignment verification, the frequency of the alignment verification should capture all the considerations i.e. time interval, changes to the testing frame and when applicable, current indicators of the alignment condition through test results.

4.3 Whether or not to improve axiality should be a matter of negotiation between the material producer and the user.

5. Verification of Alignment

5.1 A numerical requirement for alignment should specify the force, strain-gaged alignment transducer dimensions, and temperature at which the measurement is to be made. Alternate methods employed when strain levels are of particular importance may be used as described in Practices E466 or E606. When these methods are used, the numerical requirement

should specify the strain levels, strain-gaged alignment transducer dimensions and temperature at which the measurement is to be made.

NOTE 1—For a misaligned load train, the percent bending usually decreases with increasing applied force. (See Curves A, B, and C in Fig. 2.) However, in some severe instances, percent bending may increase with increasing applied force. (See Curve D in Fig. 2.)

5.2 For a verification of alignment to be reported in compliance with the current revision of E1012 a strain-gaged alignment transducer shall be used. This applies to both Type 1 and Type 2 levels of alignment verification.

5.2.1 This standard defines two types of classified testing machine alignment per the classification criteria. The type of alignment shall be noted on the report.

5.2.2 When performing an alignment of a testing machine for the first time or if normally fixed components have been adjusted or repaired, a mechanical alignment of the testing machine should be performed. For tensile and fatigue

equipment, this step can be accomplished by means of a dial indicator for concentricity alignment adjustment and with precision shims or feeler gauges with the components brought together for angularity alignment adjustment. For creep and stress-rupture machines incorporating lever arms, this step may be accomplished by means of precision shims or feeler gauges, and/or double knife-edge couplings, and/or suitable components below the lower crosshead of the testing machine. Severe damage may occur to a strain-gaged alignment transducer if this step is omitted. A Mechanical Alignment is a preliminary step, but is not a substitute for a verification of alignment using a strain-gaged alignment transducer.

5.3 *Testing Machine Alignment Type 1*—A general alignment verification of the defined load train components. It is understood that some parts of the testing machine (i.e. the crosshead, actuator or grip faces) may be moved or exchanged in normal day to day testing. This alignment verification should

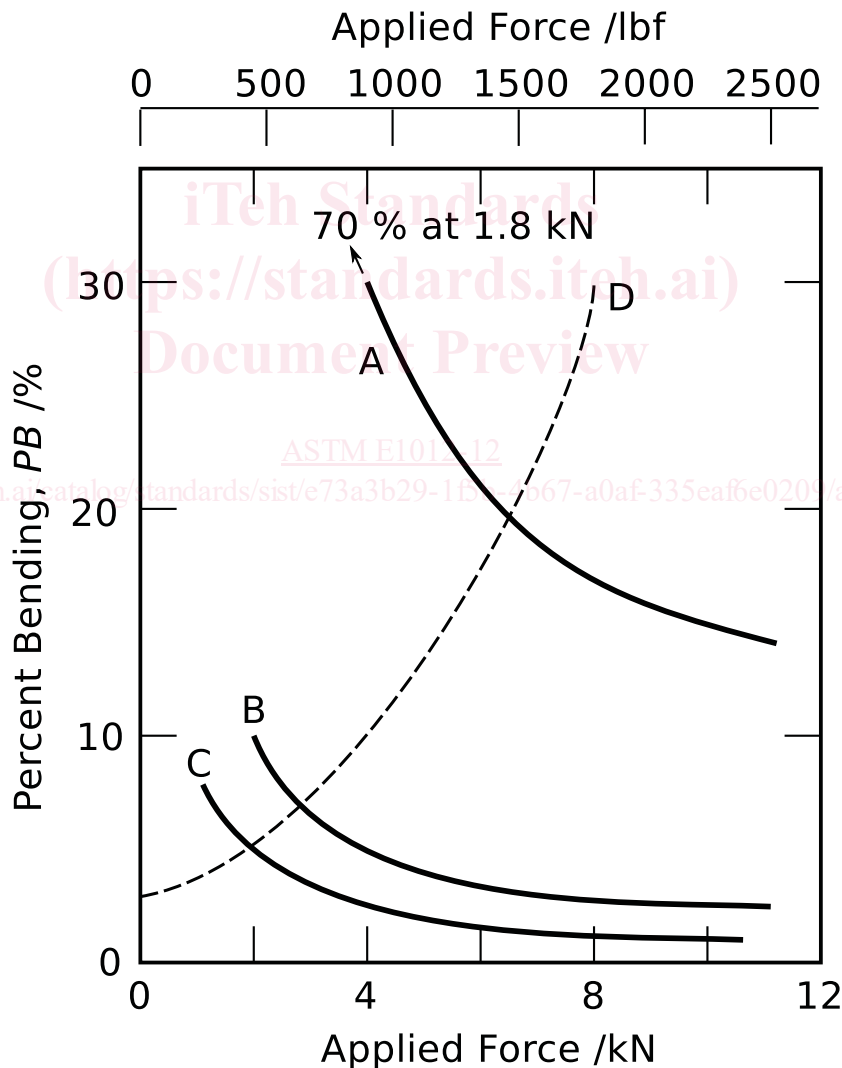

NOTE 1—Curve A: Machine 1, threaded grip ends (11)

NOTE 2—Curve B: Machine 2, buttonhead grip ends (11)

NOTE 3—Curve C: Machine 3, grips with universal couplings (7)

NOTE 4—Curve D: schematic representation of a possible response from a concentrically misaligned load train (16)

FIG. 2 Effects of Applied Force on Percent Bending for Different Testing Machines and Gripping Methods

be conducted for the various changes to the system (i.e. adjusting the crosshead and actuator position) to demonstrate reproducibility between changing conditions. Whenever possible the alignment verification should be conducted with the testing system components at a physical position that would simulate the position in which a test specimen would be installed. The strain-gaged alignment transducer geometry and material shall be adequately referenced in the verification report.

NOTE 2—Type 1 typically refers to static test equipment, such as tensile, stress rupture, or creep machines.

NOTE 3—For creep and stress rupture machines, the lever arm should be in a level position when performing alignment verification.

5.3.1 For some material testing, it is not possible or feasible to use all parts of the force application components when verifying alignment. In such cases alternative components may be used. The use of alternative components shall be adequately referenced in the verification report.

5.4 *Testing Machine Alignment Type 2*—Grip-to-grip alignment verification, where the testing machine mechanical configuration is fixed and will not be changed or adjusted during the testing period. However, when testing some specimen geometries, it may be necessary to move the actuator or crosshead to install the strain-gaged alignment transducer and/or test specimens. This should be avoided if possible, but if it is necessary, care should be taken to reposition the actuator and or crosshead in the position used during the alignment. Any removable components specific to the test specimen should be assembled within the aligned grip set and a strain-gaged alignment transducer used for verification of compliance to E1012.

5.4.1 Precision machined grip housings with hydraulic or pneumatically actuated wedge inserts are commonly used in laboratory testing. These devices are specifically designed to allow for interchangeability of wedge inserts without adversely affecting the alignment of the loading train. For testing systems using these gripping configurations, grip wedge inserts may be replaced with smooth wedge inserts to assess the alignment of the testing machine under a Type 2 alignment assessment.

NOTE 4—Type 2 typically refers to dynamic test equipment, such as fatigue testing machines.

NOTE 5—Type 2 alignment requires as many of the adjustable components of the testing machine as possible to be positioned in the final verified position. This could include adjustable reaction components (i.e. crosshead) and actuators, which may otherwise be free to rotate about the loading axis.

5.5 Strain-gaged alignment transducers shall be manufactured per Section 7 of this standard. The strain-gaged alignment transducer is to be manufactured per section 7.4 as closely as possible, except that any notches may be eliminated. The same strain-gaged alignment transducer may be used for successive verifications. The materials and design should be such that only elastic strains occur at the applied forces.

5.5.1 Strain-gaged alignment transducers shall be used for both Type 1 and Type 2 Testing Machine Alignment.

6. Apparatus

6.1 This standard requires the use of a strain-gaged alignment transducer. In some cases it may be helpful to make an

assessment using extensometers or alignment components employing mechanical linkages (see Appendix X2), however these types of strain sensors do not meet the reporting requirements in Section 11.

6.2 In general, repeated force applications to strain levels approaching yielding are not good laboratory practice because they may affect the subsequently measured results by deforming or fatiguing the strain-gaged alignment transducer.

6.3 *Additional Testing Machine and Force Application Component Considerations:*

6.3.1 Poorly made components and multiple interfaces in a load train can cause major difficulty in attempting to align a test system. All components in the load train should be machined within precision machining practices with attention paid to perpendicularity, concentricity, flatness and surface finish. The number of components should be kept to a minimum.

6.3.2 Situations can arise where acceptable alignment cannot be achieved for a given testing machine, set of force application components and strain-gaged alignment transducer. In these cases, redesign and fabrication of any of the components may be needed to achieve acceptable alignment.

7. Strain-Gaged Alignment Transducer

7.1 This practice refers to cylindrical strain-gaged alignment transducers, thick rectangular strain-gaged alignment transducers, and thin rectangular strain-gaged alignment transducers. The actual strain-gaged alignment transducer geometry is dictated by the test standard to be used. These strain-gaged alignment transducers are usually dog-bone shaped with a reduced gauge section, although other strain-gaged alignment transducers such as those used for compression testing are acceptable.

NOTE 6—Since fabricating a strain-gaged alignment transducer can be a time consuming and expensive process it is best to have this step planned out well in advance of needing the strain-gaged alignment transducer.

NOTE 7—For notched specimens, it is acceptable to use a strain-gaged alignment transducer that simulates the anticipated test specimen without the notch.

7.2 This practice is valid for metallic and nonmetallic testing.

7.3 Quality of machining of alignment transducers is critical. Important features include straightness, concentricity, flatness, and surface finish. In particular, strain-gaged alignment transducers used for compression testing may be of the type that uses two parallel plates to apply compression to the ends of the strain-gaged alignment transducer. In these cases, the parallelism of the strain-gaged alignment transducer ends is extremely important as described in Test Methods E9.

7.4 The design of a strain-gaged alignment transducer should follow the same guidelines as design of standard test specimens. For static (tensile, compressive and creep) testing, strain-gaged alignment transducers conforming to test specimens shown in Test Methods E8 are appropriate. For fatigue testing applications, strain-gaged alignment transducers conforming to test specimens shown in Practice E606 are appropriate. The strain-gaged alignment transducer should be as close dimensionally to the expected test specimens as possible so that the same force application components to be used

during testing will be used during alignment. The material used for the strain-gaged alignment transducer should be as close as possible to expected test specimen materials. If the expected test material is not known, it is acceptable to use a strain-gaged alignment transducer of a common material that has similar elastic properties to expected test materials. The alignment transducer should be carefully inspected and the dimensions recorded prior to application of the strain gages.

NOTE 8—It is common laboratory practice to employ an alternate material for the strain-gaged alignment transducer in order to be able to use the strain-gaged alignment transducer for a number of repeated alignment verifications. The alternate material used should be such that the strain-gaged alignment transducer maintains its elastic properties through the loading range of interest encountered in the alignment verification (i.e. the strain-gaged alignment transducer remains below its proportional limit). A common upper strain limit for these strain-gaged alignment transducers is 3000 microstrain maximum.

7.5 Strain Gages should be selected that have known standardized performance characteristics as described in Test Methods E251. Strain gage manufacturers provide detailed information about the strain gages available. Gages with gauge lengths of approximately 10 % of the reduced section of the alignment transducer or less should be selected. The gages should be as small as practical to avoid any strain averaging effects with adjacent gages. Temperature compensated gages that are all of the same type and from the same batch (same gage factor, transverse sensitivity and temperature coefficient) should be used.

7.6 Strain gages should be installed according to procedures in Guide E1237. A commonly used method for marking the intended strain gage locations on the alignment transducer is to precisely scribe shallow longitudinal marks and transverse marks where the strain gages are to be applied. The gages are then aligned with the scribe marks when bonding. The gage placements can be inspected after installation.

7.6.1 Surface preparation for strain gage bonding can influence mechanical properties. The strain-gaged alignment transducer should not be expected to exhibit the same mechanical properties as a standard test specimen would.

7.7 Configuration of Strain-Gaged Alignment Transducers:

NOTE 9—External specifications and requirements may dictate specific configuration for number of gages and gage spacings.

7.7.1 The cross section of a strain-gaged alignment transducer may be cylindrical, thick rectangular (those with width to thickness ratio of less than three) or thin rectangular (those with width to thickness ratio of three or larger). Strain-gaged alignment transducers should have a minimum of two sets of four gages, but in some cases may have two sets of three gages. A third set of strain gages may be added to provide additional information. A single set of gages is acceptable in some cases. Fig. 3 shows the configurations of these strain-gaged alignment transducers.

7.7.2 Requirements for Cylindrical Strain-Gaged Alignment Transducers:

7.7.2.1 For strain-gaged alignment transducers with reduced section length 12 mm (0.5 in) or greater two sets of four gages are acceptable. An additional set of gages at the center of the reduced section A, is also acceptable and can provide additional information. For strain-gaged alignment transducers with reduced section length, A, less than 12 mm (0.5 in), a single set of strain gages in the center of the length of the reduced section is acceptable.

7.7.2.2 Cylindrical strain-gaged alignment transducers may have sets of either three gages or four gages. Four-gage configurations shall have gages equally spaced at 90 degrees around the circumference of the strain-gaged alignment transducer. Three-gage configurations shall have gages equally

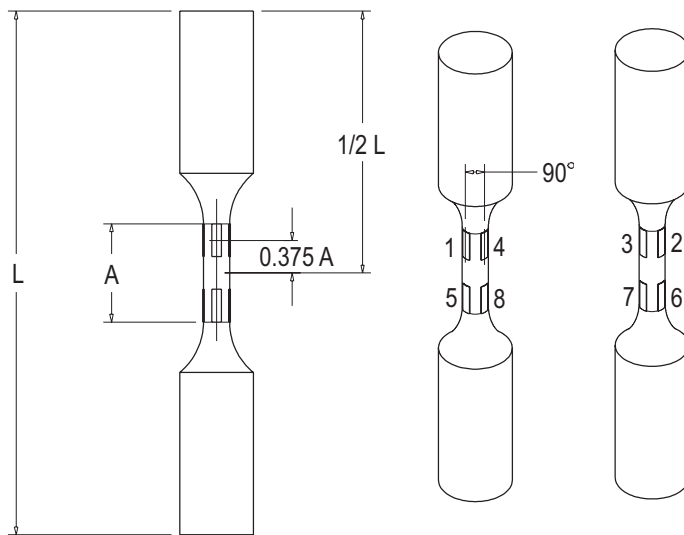

Cylindrical 90° Spacing
Figure A

FIG. 3 A Locations of Strain Sensors on (A) Cylindrical, (B) Thick rectangular and (C) Thin Rectangular Strain-Gaged Alignment transducers (Numbers Indicate Positions of Strain Sensors)

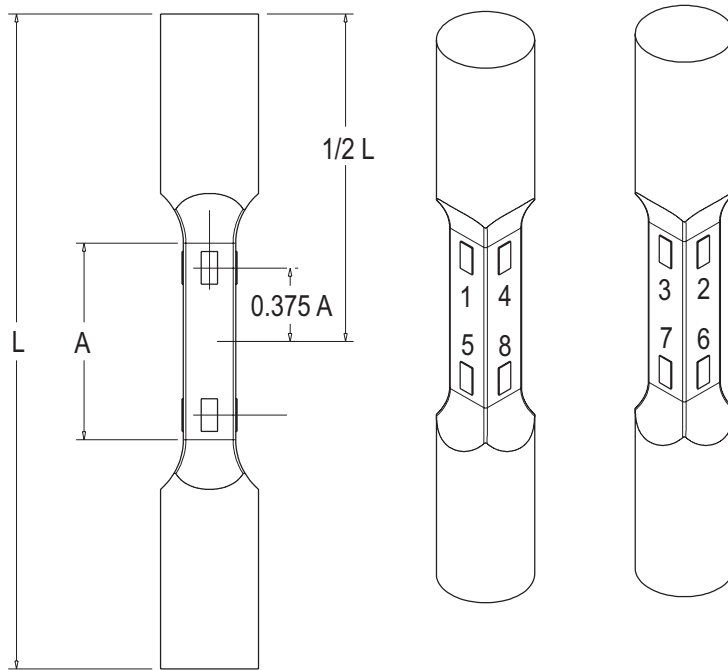

Thick Rectangular
Figure B

FIG. 3 B Locations of Strain Sensors on (A) Cylindrical, (B) Thick rectangular and (C) Thin Rectangular Strain-Gaged Alignment transducers (Numbers Indicate Positions of Strain Sensors) (continued)

spaced at 120 degrees around the circumference of the strain-gaged alignment transducer.

NOTE 10—With three-gage, 120 degree spaced configurations it can be more difficult to detect a malfunctioning gage.

7.7.2.3 In a two set strain-gaged alignment transducer the gages shall be placed equidistant from longitudinal center at a distance $A_3 = 0.375 A$. In a three gage set strain-gaged alignment transducer one set of gages shall be placed at the longitudinal center of the alignment transducer and the other two shall be placed at a distance $A_3 = 0.375 A$ from the longitudinal center of the alignment transducer. In a one gage set strain-gaged alignment transducer, the gages shall be placed on the longitudinal center of the alignment transducer.

7.7.3 Requirements for Thick Rectangular Strain-Gaged Alignment Transducers:

7.7.3.1 For strain-gaged alignment transducers with reduced section length 12 mm (0.5 in) or greater two sets of four gages are acceptable. An additional set of gages at the center of the reduced section A , is also acceptable and can provide additional information. For strain-gaged alignment transducers with reduced section length, A , less than 12 mm (0.5 in), a single set of strain gages in the center of the length of the reduced section is acceptable. Thick rectangular strain-gaged alignment transducers shall have gages equally positioned on all four faces of the strain-gaged alignment transducer.

7.7.3.2 In a two gage set strain-gaged alignment transducer the gages shall be placed equidistant from longitudinal center at a distance $A_3 = 0.375 A$. In a three gage set strain-gaged alignment transducer one set of gages shall be placed at the

longitudinal center of the alignment transducer and the other two shall be placed at a distance $A_3 = 0.375 A$ from the longitudinal center of the alignment transducer. In a one gage set strain-gaged alignment transducer, the gages shall be placed on the longitudinal center of the alignment transducer.

NOTE 11—For thick rectangular strain-gaged alignment transducers, the differences in adjacent dimensions of the gage section can lead to differences in the sensitivities of gages on these surfaces. This in turn can lead to difficulties in making adjustments to bring a test setup into good alignment.

7.7.4 Requirements for Thin Rectangular Strain-Gaged Alignment Transducers:

7.7.4.1 For strain-gaged alignment transducers with reduced section length 12 mm (0.5 in.) or greater two sets of four gages are acceptable. An additional set of gages at the center of the reduced section A , is also acceptable and can provide additional information. For strain-gaged alignment transducers with reduced section length, A , less than 12 mm (0.5 in.), a single set of strain gages in the center of the length of the reduced section is acceptable.

7.7.4.2 Thin rectangular strain-gaged alignment transducers shall have sets of 4 gages equally spaced on the two wide faces of the strain-gaged alignment transducer. Gages shall be in the same position on both faces of the strain-gaged alignment transducer. In a two gage set strain-gage alignment transducer the gages shall be placed equidistant from longitudinal center at a distance $A_3 = 0.375 A$. In a three gage set strain-gaged alignment transducer one set of gages shall be placed at the