



Designation: ~~E2242-07~~ Designation: E2242 - 12

Standard Test Method for Column Percolation Extraction of Mine Rock by the Meteoric Water Mobility Procedure¹

This standard is issued under the fixed designation E2242; the number immediately following the designation indicates the year of original adoption or, in the case of revision, the year of last revision. A number in parentheses indicates the year of last reapproval. A superscript epsilon (ϵ) indicates an editorial change since the last revision or reapproval.

1. Scope

1.1 This test method provides a procedure for the column percolation extraction of mine rock in order to determine the potential for dissolution and mobility of certain constituents by meteoric water.

1.2 This test method is intended to describe the procedure for performing column percolation extractions only. It does not describe all types of sampling and analytical requirements that may be associated with its application.

1.3 The values stated in SI units are to be regarded as the standard.

1.4 *This standard does not purport to address all of the safety concerns, if any, associated with its use. It is the responsibility of the user of this standard to establish appropriate safety and health practices and determine the applicability of regulatory limitations prior to use.*

2. Referenced Documents

2.1 ASTM Standards:²

D1193 Specification for Reagent Water

D1293 Test Methods for pH of Water

D6234 Test Method for Shake Extraction of Mining Waste by the Synthetic Precipitation Leaching Procedure

D7237 Test Method for Free Cyanide with Flow Injection Analysis (FIA) Utilizing Gas Diffusion Separation and Amperometric Detection

E50 Practices for Apparatus, Reagents, and Safety Considerations for Chemical Analysis of Metals, Ores, and Related Materials

E135 Terminology Relating to Analytical Chemistry for Metals, Ores, and Related Materials ~~E389 Test Method for Particle Size or Screen Analysis at No. 4 (4.75-mm) Sieve and Coarser for Metal-Bearing Ores and Related Materials~~

E691 Practice for Conducting an Interlaboratory Study to Determine the Precision of a Test Method

E877 Practice for Sampling and Sample Preparation of Iron Ores and Related Materials for Determination of Chemical Composition

E882 Guide for Accountability and Quality Control in the Chemical Analysis Laboratory

E1601 Practice for Conducting an Interlaboratory Study to Evaluate the Performance of an Analytical Method

2.2 Other References:

Meteoric Water Mobility Procedure, Bureau of Mining Regulation and Reclamation, Nevada Division of Environmental Protection, 9/19/90

Standard Methods for the Examination of Water and Wastewater, 18th edition, APHA/AWWA/WEF, 1992

3. Terminology

3.1 Definitions:

3.1.1 For definitions of terms used in this test method, see Terminology E135.

3.1.2 *meteoric water*—rainfall that has the potential to contact materials and mobilize soluble constituents from mine rock at a mining or mineral processing site.

¹ This test method is under the jurisdiction of ASTM Committee E01 on Analytical Chemistry for Metals, Ores, and Related Materials and is the direct responsibility of Subcommittee E01.02 on Ores, Concentrates, and Related Metallurgical Materials.

Current edition approved June 1, 2007; 2012. Published June 2007; July 2012. Originally approved in 2002. Last previous edition approved in 2002 as E2242 - 027. DOI: 10.1520/E2242-07-10.1520/E2242-12.

² For referenced ASTM standards, visit the ASTM website, www.astm.org, or contact ASTM Customer Service at service@astm.org. For Annual Book of ASTM Standards volume information, refer to the standard's Document Summary page on the ASTM website.

3.1.3 *mine rock*—ore, waste rock or overburden excavated in order to recover metals or minerals during mining operations or coarse processed ore such as heap leach spoils.

4. Summary of Test Method

4.1 The test material is placed in a plastic column and contacted with an equal weight of water during a 24 h leaching period. The extract is collected and preserved for analysis of inorganic constituents.

5. Significance and Use

5.1 This test method is intended as a means for obtaining an extract from mine rock samples. The extract may be used to estimate the final pH and release of certain constituents of the test sample under the laboratory conditions described in this test method.

5.2 The pH of the extraction fluid used in this test method should reflect the pH of precipitation in the geographic region in which the mine rock is being evaluated.

5.3 This test method is designed to mobilize potential contaminants present in the solids, so that the resulting extract can be used to assess leachate that could potentially be produced from mine rock in the field.

5.4 This test method has not been demonstrated to simulate actual site leaching conditions.

5.5 This test method produces extracts that are amenable to the determination of both major and minor (trace) constituents. When minor constituents are being determined, it is especially important that precautions be taken in sample preservation, storage and handling to avoid possible contamination of the extracts.

5.6 This test method is a comparative method intended for use as a routine method for monitoring mine rock. It is assumed that all who use this method will be trained analysts capable of performing skillfully and safely. It is expected that work will be performed in a properly equipped laboratory under appropriate quality control practices such as those described in Guide E882.

6. Interferences

6.1 This test method may not be suitable for obtaining extracts from finely divided solids (such as: finely crushed drill cuttings, clays, sludges, mill tailings, etc.), due to difficulty in obtaining a representative extract solution. If it takes more than 48 h for the column to produce an extract which has a mass equivalent to 70 % of the dry test sample weight, use of an alternate extraction procedure may be required, such as Test Method D6234.

NOTE 1—See Appendix X1 for the alternative bottle roll extraction option for fine-grained solids.

7. Apparatus

7.1 *Drying Pans or Dishes*, for moisture content determinations, 1 kg capacity.

7.2 *Extraction Column*, PVC column of 15-cm (6-in.) O.D. of sufficient height to contain a minimum of 5 kg of test sample with a feed particle size that just passes a 5-cm (2-in.) sieve and sufficient additional height to contain applied water volume should poor percolation occur. For a 5 kg test sample, a 15 cm O.D. × 45 cm high column is recommended. Additional column height will be required for test sample quantities greater than 5 kg. The bottom of the column must be sealed and a solution discharge outlet situated above the sealed bottom of the column and below a perforated support plate. A drawing of a suitable extraction column is shown in Fig. 1.

7.3 *Filtration Device*, of a composition suitable to the nature of the analyses to be performed and equipped with a 0.45 μm pore size filter. An assembly for pre-filtration or a centrifuge may be required if 0.45 μm filtration is difficult.

7.4 *Filter Media*, glass wool (inert) or a plastic fiber pad is placed onto the support plate before loading the laboratory sample into the column, to minimize fines migration, and onto the top of the test sample after column loading, to aid in making an even water distribution.

7.5 *Laboratory Balance*, capable of weighing to 1.0 g.

7.6 *pH Meter*, with a readability of 0.01 units and an accuracy of at least ± 0.05 units at 25 °C.

7.7 *Tubing*, surgical or synthetic tubing sufficient in diameter and length for the extraction column assembly (pump, column outlet).

7.8 *Water and Extract Containers*, sufficient in size to contain the water added during extraction. Containers must be covered to avoid contamination.

7.9 *Water Metering Device*, a metering pump or constant head device to insure constant rate extraction fluid application during column percolation.

8. Reagents and Materials

8.1 *Purity of Reagents*—Reagent grade chemicals shall be used in all tests. Unless otherwise indicated, it is intended that all reagents shall conform to the specifications of the Committee on Analytical Reagents of the American Chemical Society, where

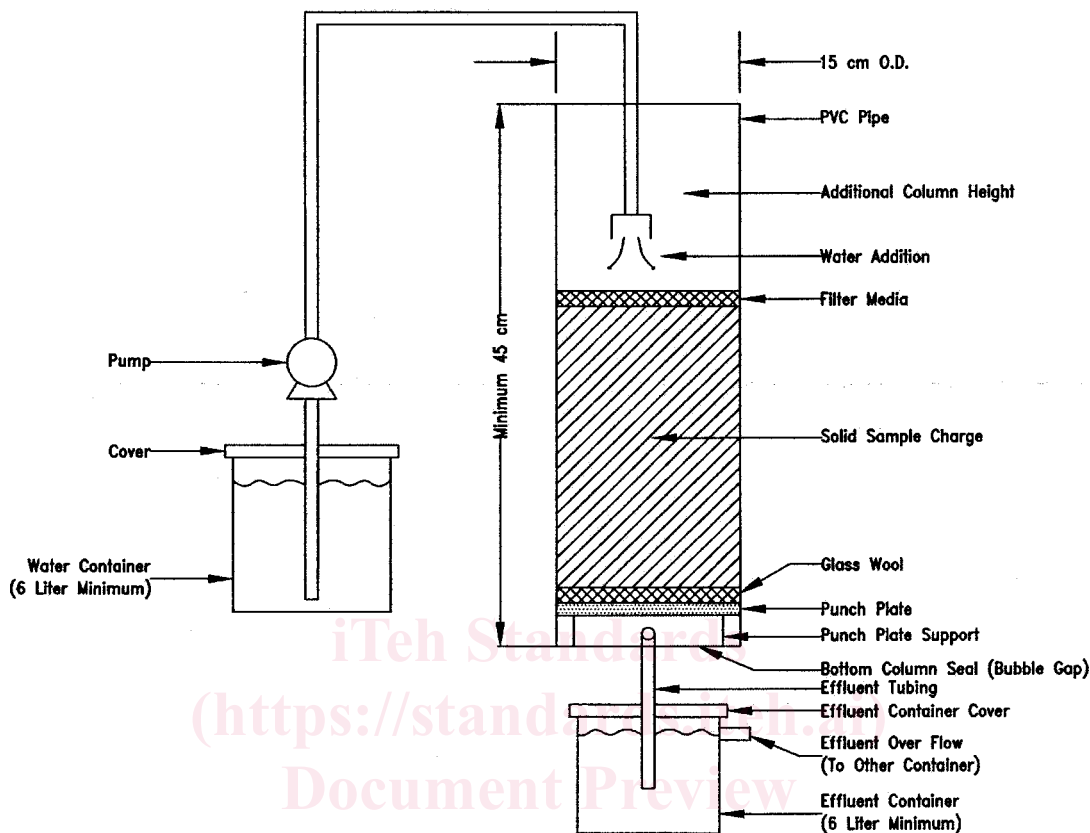

iteh Standards (https://standards.iteh.ai/ Document Preview

ASTM E2242-12

https://standards.iteh.ai/catalog/standards/sist/9cf483b2-c2a1-4700-8662-6ddef70a57bf/astm-e2242-12

- Notes:
- 1) Extraction device set on appropriate platform above effluent container to allow gravity flow of effluent and drain.
 - 2) Constant influent application rate accomplished by metering pump or constant head apparatus.

FIG. 1 Column Percolation Extraction Device (Meteoric Water Mobility Procedure)

such specifications are available.³ Other grades may be used, provided it is first ascertained that the reagent is of sufficiently high purity to permit its use without lessening the accuracy of the determination.

8.2 *Purity of Water*—Unless otherwise indicated, references to water shall be understood to mean Type II reagent water at 18 °C to 27 °C conforming to Specification D1193³. Type III or V may be used if they effect no measurable change in the blank or sample.

9. Hazards

9.1 For precautions to be observed in the use of analytical methods associated with this standard, refer to Practices E50.

10. Sampling and Sample Preparation

10.1 The amount of gross sample to be sent to the laboratory should be sufficient to perform the ~~solids~~moisture content determination as specified in 10.3, and to provide at least 5 kg of test sample on a dry weight basis for extraction. Gross sample

³ *Reagent Chemicals, American Chemical Society Specifications, American Chemical Society, Washington, DC. For suggestions on the testing of reagents not listed by the American Chemical Society, see Poole, Dorset, U.K., and the United States Pharmacopeia and National Formulary, U.S. Pharmaceutical Pharmacopeial Convention, Inc. (USPC), Rockville, MD.*

weights in the range of 7 kg to 25 kg are appropriate.

NOTE 4—Information on obtaining representative samples can also be found in Pierre Gy's Sampling Theory and Sampling Practice⁴ and in Practice E877.

10.2 In order to prevent sample contamination or constituent loss prior to extraction, keep the samples in closed containers appropriate to sample type and desired analysis.

10.3 *Moisture Determination*—Remove the gross sample from the container and blend by coning or rolling to obtain a sample for feed moisture content with a minimum of 500 g dry weight.

10.3.1 Weigh the moisture test sample and dry to constant weight ($\pm 0.05\%$) at $105\text{ }^{\circ}\text{C} \pm 2\text{ }^{\circ}\text{C}$ and record the weight.

10.3.2 Calculate the moisture content of the test sample as follows:

$$M = \frac{100(B - A)}{B} \quad (1)$$

E2242-12_1

where:

A = mass of sample after drying, g,

B = wet mass of sample, g, and

M = moisture content, %.

10.4 Separate the remaining laboratory sample on a 5-cm (2-in.) sieve. Save the minus 5-cm fraction for recombination with the crushed plus 5-cm fraction. The screening time or end point is when additional periods of shaking fail to change the results by more than 0.3% (Method E389) 0.3%. For highly friable material an acceptable end point shall be determined experimentally.

10.5 Weigh the plus and minus 5-cm sieve fractions, calculate and record the weight percent retained on the 5-cm sieve as follows:

E2242-12_2

where:

R = weight retained on the 5-cm sieve, %,

C = mass retained on the 5-cm sieve, g, and

D = mass passing the 5-cm sieve, g.

10.6 Crush or hand break the materials retained on the 5-cm sieve so that they just pass through the 5-cm (2-in.) sieve, combine with the saved fraction passed through the 5-cm sieve and mix the prepared sample.

10.7 Thoroughly blend the prepared sample and calculate the minimum test sample weight containing 5 kg dry weight, based on the feed moisture content from 10.3, as follows:

E2242-12_3

where:

S = minimum sample mass for testing, g and

M = moisture content, %.

10.8 Divide the prepared sample, if necessary, to obtain a test sample suitable for processing in the column apparatus but not less than the minimum sample weight from 10.7. and weigh to ± 1 g. Label and reserve any excess prepared sample for any additional testing which may be required.

10.9 Calculate the dry weight of the test sample as follows:

E2242-12_4

where:

L = dry mass of the test sample, g,

E = gross mass of the test sample, g, and

M = moisture content of the gross sample, %.

11. Procedure

11.1 Place filter media (7.4) in the bottom of the extraction column and load the laboratory sample incrementally (~1-kg/increment) into the column. To minimize particle segregation and compaction during column loading, the sample portions shall be dropped from no more than 0.6 m (24 in.) when introduced from the top of the column, and no tamping, shaking, or other methods to compact the sample will be employed. Place filter media over the test sample in the column.

11.2 Use a water addition rate of 3.5 mL/min for minimum weight samples in the range of 5 kg to 5.5 kg dry weight.

11.2.1 For samples greater than 5.5 kg dry weight, calculate the rate of water addition to the column to pass a weight of water equal to the dry weight of the test sample during the 24 h test period as follows:

⁴ Pitard, F., *Pierre Gy's Sampling Theory and Sampling Practice*, Vols. I and II, CRC Press, 1989.