International Standard



3011

INTERNATIONAL ORGANIZATION FOR STANDARDIZATION • МЕЖДУНАРОДНАЯ ОРГАНИЗАЦИЯ ПО СТАНДАРТИЗАЦИИ • ORGANISATION INTERNATIONALE DE NORMALISATION

Rubber or plastics coated fabrics — Determination of resistance to ozone cracking under static conditions

Supports textiles revêtus de caoutchouc ou de plastique — Détermination de la résistance aux craquelures dues à l'ozone dans des conditions statiques

Second edition — 1981-12-15

ITeH STANDARD PREVIEW
(standards.iteh.ai)

ISO 3011:1981

<https://standards.iteh.ai/catalog/standards/sist/1c7d6165-3a42-47ac-9d20-24d9088bffb/iso-3011-1981>

UDC 678.01

Ref. No. ISO 3011-1981 (E)

Descriptors : textiles, coated fabrics, rubber products, plastics, tests, artificial ageing tests, oxidation tests, chemical resistance, ozone, crack resistance.

Foreword

ISO (the International Organization for Standardization) is a worldwide federation of national standards institutes (ISO member bodies). The work of developing International Standards is carried out through ISO technical committees. Every member body interested in a subject for which a technical committee has been set up has the right to be represented on that committee. International organizations, governmental and non-governmental, in liaison with ISO, also take part in the work.

Draft International Standards adopted by the technical committees are circulated to the member bodies for approval before their acceptance as International Standards by the ISO Council.

International Standard ISO 3011 was developed by Technical Committee ISO/TC 45, *Rubber and rubber products*.

This second edition was submitted directly to the ISO Council, in accordance with clause 5.10.1 of part 1 of the Directives for the technical work of ISO. It cancels and replaces the first edition (i.e. ISO 3011-1975), which had been approved by the member bodies of the following countries:

Australia	India	Sweden
Austria	Italy	Switzerland
Belgium	Netherlands	Thailand
Brazil	New Zealand	United Kingdom
Egypt, Arab Rep. of	Portugal	USA
France	Romania	USSR
Hungary	South Africa, Rep. of	

No member body had expressed disapproval of the document.

Rubber or plastics coated fabrics — Determination of resistance to ozone cracking under static conditions

1 Scope and field of application

This International Standard specifies a method for the determination of the resistance of fabrics coated with rubber or plastics to ozone cracking under static conditions.

The test is designed to determine the relative resistance to cracking of fabrics coated with rubber or plastics when exposed under static strain to air containing ozone in the absence of direct sunlight.

Like all ageing tests, it should be considered as a means of comparing articles of the same composition and destined for the same application, but not as an absolute criterion. It is preferable to limit the significance of the test by considering it only as a means of control when a fabrication attains a resistance superior to a threshold given in comparison with a certain type of degradation.

Taking these remarks into account, the results obtained at the time of test cannot be taken as a prediction of the length of life of the product.

2 Reference

ISO 1431/1, *Rubber, vulcanized — Resistance to ozone cracking — Part 1 : Static strain test.*

3 Principle

Exposure of test pieces to ozone under specified conditions. Assessment of the effects of ozone by measurement of the time at which the first crack appears or of the time of exposure during which no cracks appear, as appropriate.

4 Apparatus

4.1 Test chamber.

The test chamber and ancillary apparatus shall be as specified in ISO 1431/1.

4.2 Test piece holder (see the figure).

The test piece holder shall consist of a mandrel and clamps. The diameter of the mandrel shall be 2, 5, 10 or 20 times the thickness of the test piece, as agreed between the interested

parties, but not less than 0,8 mm. The mandrel and clamps shall be made of a material which does not absorb ozone, for example stainless steel, polymethacrylate, wood coated with a lacquer that does not absorb ozone, or duralumin, and shall have a smooth finish.

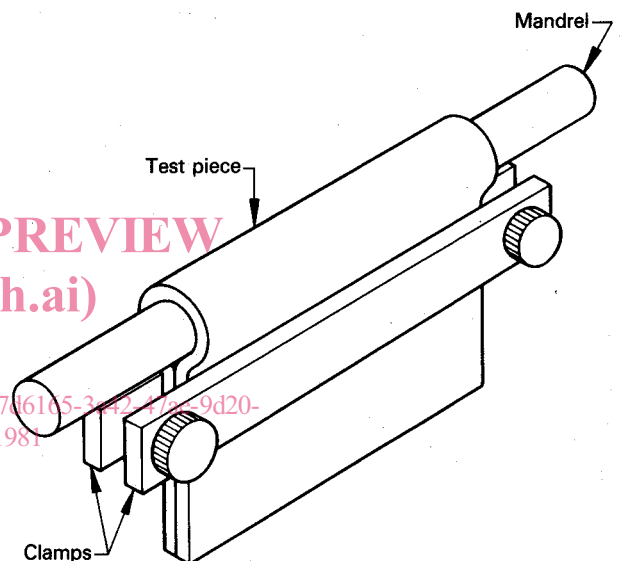

Figure — Test piece holder

5 Test pieces

5.1 Type

The test pieces shall be of sufficient size to permit proper evaluation of the exposed surface after test, and satisfactory comparison of different test pieces. The preferred size is 25 mm wide and 100 mm long.

5.2 Selection

Test pieces shall be taken at least 0,10 m from the selvage, and at least 1 m from the beginning or end of a sample piece which is as representative as possible of the whole consignment.

5.3 Number

Three test pieces in each direction of the fabric for each coated face shall be prepared.

6 Time intervals before testing

Unless otherwise specified for technical reasons, the following requirements for time intervals shall be observed.

For all test purposes, the minimum time between manufacture and testing shall be 16 h.

For non-product tests, the maximum time between manufacture and testing shall be 4 weeks and for evaluations intended to be comparable, the tests, as far as possible, should be carried out after the same time interval.

For product tests, whenever possible, the time between manufacture and testing should not exceed 3 months. In other cases, tests shall be made within 2 months of the date of receipt of the product by the customer.

7 Test conditions

7.1 Ozone concentration

The ozone concentration shall comply with the requirements of sub-clause 8.1 of ISO 1431/1.

7.2 Temperature

The temperature of test shall comply with the requirements of sub-clause 8.2 of ISO 1431/1.

7.3 Mounting of test pieces under stress and conditioning

The test piece shall be wrapped round a mandrel with the surface under test on the outside and its ends held by the clamps tightly enough for the mandrel just to be able to revolve freely in the test piece.

Multiple samples of the same thickness may be wrapped around a single mandrel.

The test piece, assembled on its mandrel, shall be conditioned in a substantially ozone and draught-free atmosphere at the standard laboratory temperature for 48 h, after which the test piece shall be placed in the test chamber.

8 Procedure

Carry out the procedure in accordance with clause 9 of ISO 1431/1, and dispose the test pieces in the chamber so that they are at least 10 mm from each other and from the wall of the chamber.

Examine the test pieces under a magnification of between X 5 and X 10.

9 Test report

The test report shall include the following information :

- a) a reference to this International Standard;
- b) the reference of the sample;
- c) the thickness of the sample and the mandrel diameter;
- d) the ozone concentration and the method of measuring it;
- e) the temperature of test;
- f) the time, in hours, at which the first crack appeared on each test piece or the time of exposure during which no cracks appeared, as appropriate.

iTeh STANDARD PREVIEW
(standards.iteh.ai)

ISO 3011-1981

<https://standards.iteh.ai/catalog/standards/sist/c7d6165-3a42-47ae-9d20-24df9088bffb/iso-3011-1981>