



Standard Practice for Mechanical Mixing of Hydraulic Cement Pastes and Mortars of Plastic Consistency¹

This standard is issued under the fixed designation C305; the number immediately following the designation indicates the year of original adoption or, in the case of revision, the year of last revision. A number in parentheses indicates the year of last reapproval. A superscript epsilon (ϵ) indicates an editorial change since the last revision or reapproval.

1. Scope*

1.1 This practice covers the mechanical mixing of hydraulic cement pastes and mortars of plastic consistency.

1.2 *This standard does not purport to address all of the safety concerns, if any, associated with its use. It is the responsibility of the user of this standard to establish appropriate safety and health practices and determine the applicability of regulatory limitations prior to use.*

2. Referenced Documents

2.1 *ASTM Standards:*²

C511 [Specification for Mixing Rooms, Moist Cabinets, Moist Rooms, and Water Storage Tanks Used in the Testing of Hydraulic Cements and Concretes](#)

C778 [Specification for Sand](#)

3. Significance and Use

3.1 This practice is intended for use in the mechanical mixing of pastes and mortars for the testing of hydraulic cements.

4. Apparatus

4.1 *Mixer*—The mixer shall be an electrically driven mechanical mixer of the epicyclic type, which imparts both a planetary and a revolving motion to the mixer paddle. The mixer shall have a minimum of two speeds, controlled by definite mechanical means. (Rheostat adjustment of speed will not be acceptable.) The first, or slow speed shall revolve the paddle at a rate of 140 ± 5 r/min, with a planetary motion of approximately 62 r/min. The second speed shall revolve the paddle at a rate of 285 ± 10 r/min, with a planetary motion of approximately 125 r/min. The electric motor shall be at least 124 W ($\frac{1}{6}$ hp). The mixer shall be equipped with either an adjustment screw which is an integral part of the mixer or a clearance adjustment bracket such as the one shown in Fig. 1 (Note 1) to provide clearance between the lower end of the paddle and the bottom of the bowl that is not greater than 2.5 mm but not less than 0.8 mm (Note 2) when the bowl is in the mixing position.

NOTE 1—When the bracket is in the proper position beneath the motor housing, the lugs are to the front and facing upward and the heads of the adjustment screws are to the rear and facing downward in the path of the sliding frame that holds the bowl. It is intended that the bracket be fastened at the front housing connection by inserting replacement screws on an appropriate size upward through the opening in each lug and into the existing threaded holes in the bottom of the motor housing. The original stops for the sliding frame are to be filed down if they prevent the frame from coming in contact with the adjustment screws.

NOTE 2—This is the approximate diameter of a grain of 20-30 sand as described in Specification C778.

4.2 *Paddle*—The paddle shall be readily removable, made of stainless steel, and shall conform to the basic design shown in Fig. 2. The dimensions of the paddle shall be such that when in the mixing position the paddle outline conforms to the contour of the bowl used with the mixer, and the clearance between corresponding points on the edge of the paddle and the side of the bowl in the position of closest approach shall be approximately 4.0 mm but not less than 0.8 mm.

4.3 *Mixing Bowl*—The removable mixing bowl shall have a nominal capacity of 4.73 L, shall be of the general shape and comply with the limiting dimensions shown in Fig. 3, and shall be made of stainless steel. The bowl shall be so equipped that it will be positively held in the mixing apparatus in a fixed position during the mixing procedure. There shall be provided a lid, made of a nonabsorbing material not attacked by the cement, and shall be made of stainless steel. The bowl shall be so equipped that it will be positively held in the mixing apparatus in a fixed position during the mixing procedure. Provide an enclosure around the

¹ This practice is under the jurisdiction of ASTM Committee C01 on Cement and is the direct responsibility of Subcommittee C01.22 on Workability.

Current edition approved April 1, 2011. Published May 2011. Originally approved in 1953. Last previous edition approved in 2006 as C305-06. DOI: 10.1520/C0305-11. Current edition approved July 1, 2012. Published July 2012. Originally approved in 1953. Last previous edition approved in 2011 as C305 - 11. DOI: 10.1520/C0305-12.

² For referenced ASTM standards, visit the ASTM website, www.astm.org, or contact ASTM Customer Service at service@astm.org. For *Annual Book of ASTM Standards* volume information, refer to the standard's Document Summary page on the ASTM website.

*A Summary of Changes section appears at the end of this standard.

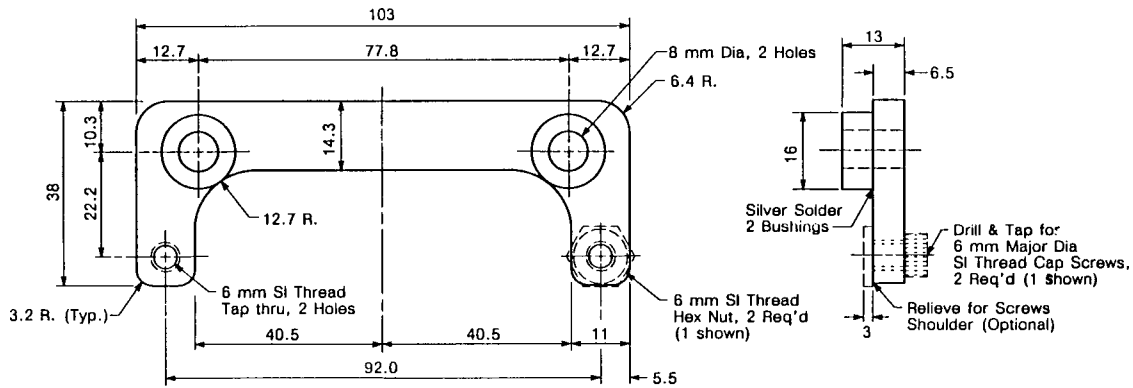

Plate and Bushings—Brass
Screws and Nuts—Steel
All Dimensions in mm

FIG. 1 Clearance Adjustment Bracket

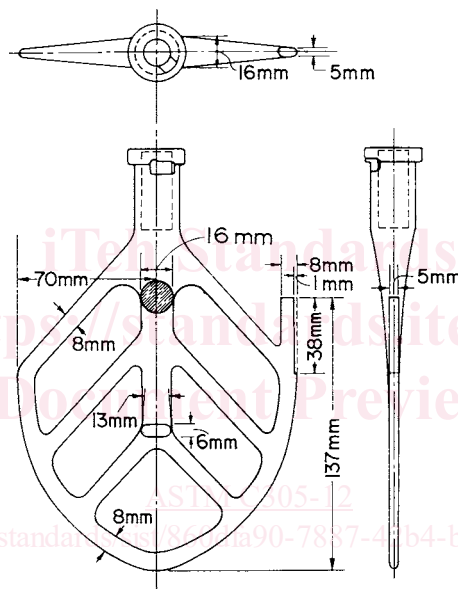

FIG. 2 Paddle

mixing bowl or a lid to minimize evaporation of water during periods of rest of the mixture. The enclosure or lid shall be made of non-absorbing material that is resistant to deterioration from the alkaline environment of cement pastes and mortars.

4.4 *Scraper*—The scraper shall consist of a semirigid rubber blade attached to a handle about 150 mm long. The blade shall be about 75 mm long, 50 mm wide, and tapered to a thin edge about 2 mm thick.

NOTE 3—A kitchen tool known as a plate and bowl scraper conforms to these requirements.

4.5 *Supplementary Apparatus*—The balances, weights, glass graduates, and any other supplementary apparatus used in measuring and preparing the mortar materials prior to mixing shall conform to the respective requirements for such apparatus as specified in the method for the particular test for which the mortar is being prepared.

5. Temperature and Humidity

5.1 The temperature and the humidity of the room and the temperature of the mixing water shall be maintained as described in Specification C511 (Section *Requirements for Cement Mixing Rooms*).

5.2 The dry materials shall be within the temperature range of the room.

6. Materials, Proportioning, and Consistency

6.1 The materials and their proportions and quantities shall conform to the requirements contained in the particular method for which the paste or mortar is being prepared.

7. Procedure for Mixing Pastes

7.1 Place the dry paddle and the dry bowl in the mixing position in the mixer. Then introduce the materials for a batch into the bowl and mix in the following manner: