



Designation: E1221 – 12

Standard Test Method for Determining Plane-Strain Crack-Arrest Fracture Toughness, K_{Ia} , of Ferritic Steels¹

This standard is issued under the fixed designation E1221; the number immediately following the designation indicates the year of original adoption or, in the case of revision, the year of last revision. A number in parentheses indicates the year of last reapproval. A superscript epsilon (ϵ) indicates an editorial change since the last revision or reapproval.

1. Scope

1.1 This test method employs a side-grooved, crack-line-wedge-loaded specimen to obtain a rapid run-arrest segment of flat-tensile separation with a nearly straight crack front. This test method provides a static analysis determination of the stress intensity factor at a short time after crack arrest. The estimate is denoted K_a . When certain size requirements are met, the test result provides an estimate, termed K_{Ia} , of the plane-strain crack-arrest toughness of the material.

1.2 The specimen size requirements, discussed later, provide for in-plane dimensions large enough to allow the specimen to be modeled by linear elastic analysis. For conditions of plane-strain, a minimum specimen thickness is also required. Both requirements depend upon the crack arrest toughness and the yield strength of the material. A range of specimen sizes may therefore be needed, as specified in this test method.

1.3 If the specimen does not exhibit rapid crack propagation and arrest, K_a cannot be determined.

1.4 The values stated in SI units are to be regarded as the standards. The values given in parentheses are provided for information only.

1.5 *This standard does not purport to address all of the safety concerns, if any, associated with its use. It is the responsibility of the user of this standard to establish appropriate safety and health practices and determine the applicability of regulatory limitations prior to use.*

2. Referenced Documents

2.1 ASTM Standards:²

- E8 Test Methods for Tension Testing of Metallic Materials
- E23 Test Methods for Notched Bar Impact Testing of Metallic Materials

¹ This test method is under the jurisdiction of ASTM Committee E08 on Fatigue and Fracture and is the direct responsibility of Subcommittee E08.07 on Fracture Mechanics.

Current edition approved May 1, 2012. Published July 2012. Originally approved in 1988. Last previous edition approved in 2010 as E1221 – 10. DOI: 10.1520/E1221-12.

² For referenced ASTM standards, visit the ASTM website, www.astm.org, or contact ASTM Customer Service at service@astm.org. For *Annual Book of ASTM Standards* volume information, refer to the standard's Document Summary page on the ASTM website.

E208 Test Method for Conducting Drop-Weight Test to Determine Nil-Ductility Transition Temperature of Ferritic Steels

E399 Test Method for Linear-Elastic Plane-Strain Fracture Toughness K_{Ic} of Metallic Materials

E616 Terminology Relating to Fracture Testing (Discontinued 1996) (Withdrawn 1996)³

E1304 Test Method for Plane-Strain (Chevron-Notch) Fracture Toughness of Metallic Materials

E1823 Terminology Relating to Fatigue and Fracture Testing

3. Terminology

3.1 Definitions:

3.1.1 Definitions in Terminology E1823 are applicable to this test method.

3.2 Definitions of Terms Specific to This Standard:

3.2.1 *conditional value of the plane-strain crack-arrest fracture toughness, K_{Qa} ($FL^{-3/2}$)*—the conditional value of K_{Ia} calculated from the test results and subject to the validity criteria specified in this test method.

3.2.1.1 *Discussion*—In this test method, side-grooved specimens are used. The calculation of K_{Qa} is based upon measurements of both the arrested crack size and of the crack-mouth opening displacement prior to initiation of a fast-running crack and shortly after crack arrest.

3.2.2 *crack-arrest fracture toughness, K_A ($FL^{-3/2}$)*—the value of the stress intensity factor shortly after crack arrest as determined from dynamic methods of analysis.

3.2.2.1 *Discussion*—The in-plane specimen dimensions must be large enough for adequate enclosure of the crack-tip plastic zone by a linear-elastic stress field.

3.2.3 *crack-arrest fracture toughness, K_a ($FL^{-3/2}$)*—the value of the stress intensity factor shortly after crack arrest, as determined from static methods of analysis.

3.2.3.1 *Discussion*—The in-plane specimen dimensions must be large enough for adequate enclosure of the crack-tip plastic zone by a linear-elastic stress field.

³ The last approved version of this historical standard is referenced on www.astm.org.

3.2.4 *plane-strain crack-arrest fracture toughness, K_{Ia} ($FL^{-3/2}$)*—the value of crack-arrest fracture toughness, K_a , for a crack that arrests under conditions of crack-front plane-strain.

3.2.4.1 *Discussion*—The requirements for attaining conditions of crack-front plane-strain are specified in the procedures of this test method.

3.2.5 *stress intensity factor at crack initiation, K_o ($FL^{-3/2}$)*—the value of K at the onset of rapid fracturing.

3.2.5.1 *Discussion*—In this test method, only a nominal estimate of the initial driving force is needed. For this reason, K_o is calculated on the basis of the original (machined) crack (or notch) size and the crack-mouth opening displacement at the initiation of a fast-running crack.

4. Summary of Test Method

4.1 This test method estimates the value of the stress intensity factor, K , at which a fast running crack will arrest. This test method is made by forcing a wedge into a split-pin, which applies an opening force across the crack starter notch in a modified compact specimen, causing a run-arrest segment of crack extension. The rapid run-arrest event suggests need for a dynamic analysis of test results. However, experimental observations (1, 2)⁴ indicate that, for this test method, an adjusted static analysis of test results provides a useful estimate of the value of the stress intensity factor at the time of crack arrest.

4.2 Calculation of a nominal stress intensity at initiation, K_o , is based on measurements of the machined notch size and the crack-mouth opening displacement at initiation. The value of K_a is based on measurements of the arrested crack size and the crack-mouth opening displacements prior to initiation and shortly after crack arrest.

5. Significance and Use

5.1 In structures containing gradients in either toughness or stress, a crack may initiate in a region of either low toughness or high stress, or both, and arrest in another region of either higher toughness or lower stress, or both. The value of the stress intensity factor during the short time interval in which a fast-running crack arrests is a measure of the ability of the material to arrest such a crack. Values of the stress intensity factor of this kind, which are determined using dynamic methods of analysis, provide a value for the crack-arrest fracture toughness which will be termed K_A in this discussion. Static methods of analysis, which are much less complex, can often be used to determine K at a short time (1 to 2 ms) after crack arrest. The estimate of the crack-arrest fracture toughness obtained in this fashion is termed K_a . When macroscopic dynamic effects are relatively small, the difference between K_A and K_a is also small (1-4). For cracks propagating under conditions of crack-front plane-strain, in situations where the dynamic effects are also known to be small, K_{Ia} determinations using laboratory-sized specimens have been used successfully to estimate whether, and at what point, a crack will arrest in a structure (5, 6). Depending upon component design, loading compliance, and the crack jump length, a dynamic analysis of

a fast-running crack propagation event may be necessary in order to predict whether crack arrest will occur and the arrest position. In such cases, values of K_{Ia} determined by this test method can be used to identify those values of K below which the crack speed is zero. More details on the use of dynamic analyses can be found in Ref (4).

5.2 This test method can serve at least the following additional purposes:

5.2.1 In materials research and development, to establish in quantitative terms significant to service performance, the effects of metallurgical variables (such as composition or heat treatment) or fabrication operations (such as welding or forming) on the ability of a new or existing material to arrest running cracks.

5.2.2 In design, to assist in selection of materials for, and determine locations and sizes of, stiffeners and arrestor plates.

6. Apparatus

6.1 The procedure involves testing of modified compact specimens that have been notched by machining. To minimize the introduction of additional energy into the specimen during the run-arrest event, the loading system must have a low compliance compared with the test specimen. For this reason a wedge and split-pin assembly is used to apply a force on the crack line. This loading arrangement does not permit easy measurement of opening forces. Consequently, opening displacement measurements in conjunction with crack size and compliance calibrations are used for calculating K_o and K_a .

6.2 Loading Arrangement:

6.2.1 A typical loading arrangement is shown in Fig. 1. The specimen is placed on a support block whose thickness should be adequate to allow completion of the test without interference between the wedge and the lower crosshead of the testing machine. The support block should contain a hole that is aligned with the specimen hole, and whose diameter should be between 1.05 and 1.15 times the diameter of the hole in the specimen. The force that pushes the wedge into the split-pin is transmitted through a force transducer.

6.2.1.1 The surfaces of the wedge, split-pin, support block, and specimen hole should be lubricated. Lubricant in the form of thin (0.13 mm or 0.005 in.) strips of TFE-fluorocarbon is preferred. Molybdenum disulfide (both dry and in a grease vehicle) and high-temperature lubricants can also be used.

6.2.1.2 A low-taper-angle wedge and split-pin arrangement is used. If grease or dry lubricants are used, a matte finish (grit blasted) on the sliding surfaces may be helpful in avoiding galling. The split-pin must be long enough to contact the full specimen thickness, and the radius must be large enough to avoid plastic indentations of the test specimen. In all cases it is recommended that the diameter of the split-pin should be 0.13 mm (0.005in.) less than the diameter of the specimen hole. The wedge must be long enough to develop the maximum expected opening displacement. Any air or oil hardening tool steel is suitable for making the wedge and split-pins. A hardness in the range from R_C 45 to R_C 55 has been used successfully. With the recommended wedge angle and proper lubrication, a loading machine producing $1/5$ to $1/10$ the expected maximum opening force is adequate. The dimensions of a wedge and split-pin

⁴ The boldface numbers in parentheses refer to the list of references at the end of this test method.

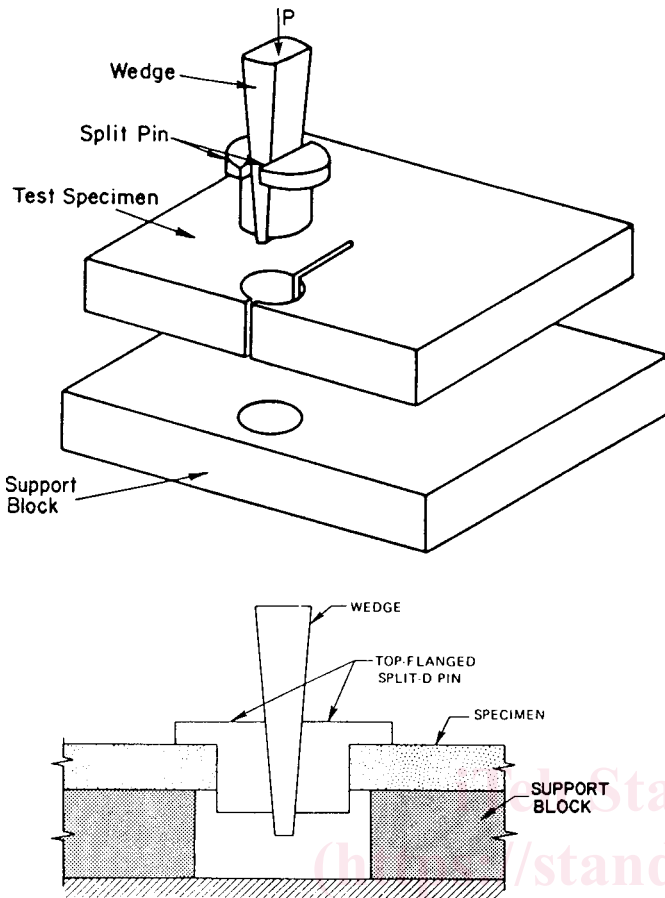

FIG. 1 Schematic Pictorial and Sectional Views Showing the Standard Arrangement of the Wedge and Split-Pin Assembly, the Test Specimen, and the Support Block

assembly suitable for use with a 25.4-mm (1.0-in.) diameter loading hole are shown in Fig. 2. The dimensions should be scaled when other hole diameters are used. A hole diameter of 1.0 in. has been found satisfactory for specimens having $125 < W < 170$ mm ($5 < W < 6.7$ in.).

NOTE 1—Specimens tested with the arrangement shown in Fig. 1 may not exhibit an adequate segment of run-arrest fracturing, for example, at testing temperatures well above the NDT temperature. In these circumstances, the use of the loading arrangement shown in Fig. 3 has been found to be helpful (2, 7) and may be employed.

6.3 *Displacement Gages*—Displacement gages are used to measure the crack-mouth opening displacement at $0.25W$ from the load-line. Accuracy within 2% over the working range is required. Either the gage recommended in Test Method E399 or a similar gage modified to accommodate conical seats is satisfactory. It is necessary to attach the gage in a fashion such that seating contact with the specimen is not altered by the jump of the crack. Two methods that have proven satisfactory for doing this are shown in Fig. 4. Other gages can be used so long as their accuracy is within 2%.

7. Specimen Configuration, Dimensions, and Preparation

7.1 Standard Specimen:

7.1.1 The configuration of a compact-crack-arrest (CCA) specimen that is satisfactory for low- and intermediate-strength

steels is shown in Fig. 5. (In this context, an intermediate-strength steel is considered to be one whose static yield stress, σ_{YS} , is of the order of 700 MPa (100 ksi) or less.)

7.1.1.1 The thickness, B , shall be either full product plate thickness or a thickness sufficient to produce a condition of plane-strain, as specified in 9.3.3.

7.1.1.2 Side grooves of depth $B/8$ per side shall be used. For alloys that require notch-tip embrittlement (see 7.1.3.2) the side grooves should be introduced after deposition of the brittle weld.

7.1.1.3 The specimen width, W , shall be within the range $2B \leq W \leq 8B$.

7.1.1.4 The displacement gage shall measure opening displacements at an offset from the load line of $0.25W$, away from the crack tip.

7.1.2 Specimen Dimensions:

7.1.2.1 In order to limit the extent of plastic deformation in the specimen prior to crack initiation, certain size requirements must be met. These requirements depend upon the material yield strength. They also depend upon K_{Ic} , and therefore the K_{Ic} needed to achieve an appropriate run-arrest event.

7.1.2.2 The in-plane specimen dimensions must be large enough to allow for the linear elastic analysis employed by this test method. These requirements are given in 9.3.2 and 9.3.4, in terms of allowable crack jump lengths.

7.1.2.3 For a test result to be termed plane-strain (K_{Ia}) by this test method, the specimen thickness, B , should meet the requirement given in 9.3.3.

7.1.3 Starting Notch:

7.1.3.1 The function of the starting notch is to produce crack initiation at an opening displacement (or wedging force) that will permit an appropriate length of crack extension prior to crack arrest. Different materials require different starter notch preparation procedures.

7.1.3.2 The recommended starter notch for low- and intermediate-strength steels is a notched brittle weld, as shown in Fig. 6. It is produced by depositing a weld across the specimen thickness. Guidelines on welding procedures are given in Appendix X1.

7.1.3.3 Alternative crack starter configurations (8) and embrittlement methods may also be used. Examples of both alternative configurations and alternative test methods are also described in Appendix X1.

7.1.3.4 While it is expected that a_o values for the starting notch will typically lie in the range $0.30W \leq a_o \leq 0.40W$, it is sometimes useful to utilize values as low as $0.20W$. The lower initial value of a_o/W results in a greater and quicker drop in the crack driving force as the crack extends. This may aid in arresting the running crack at a shorter final crack length and could be useful for conditions where the crack extension is too great with larger initial a_o/W values.

8. Procedure

8.1 *Number of Tests*—It is recommended that at least three valid test results be obtained at a single test temperature.

8.2 *Specimen Measurement*—Measure the specimen thickness, B , and the crack plane thickness, B_N , to $\pm 1\%$ of B . Measure the specimen width, W , to $\pm 1\%$ of W .

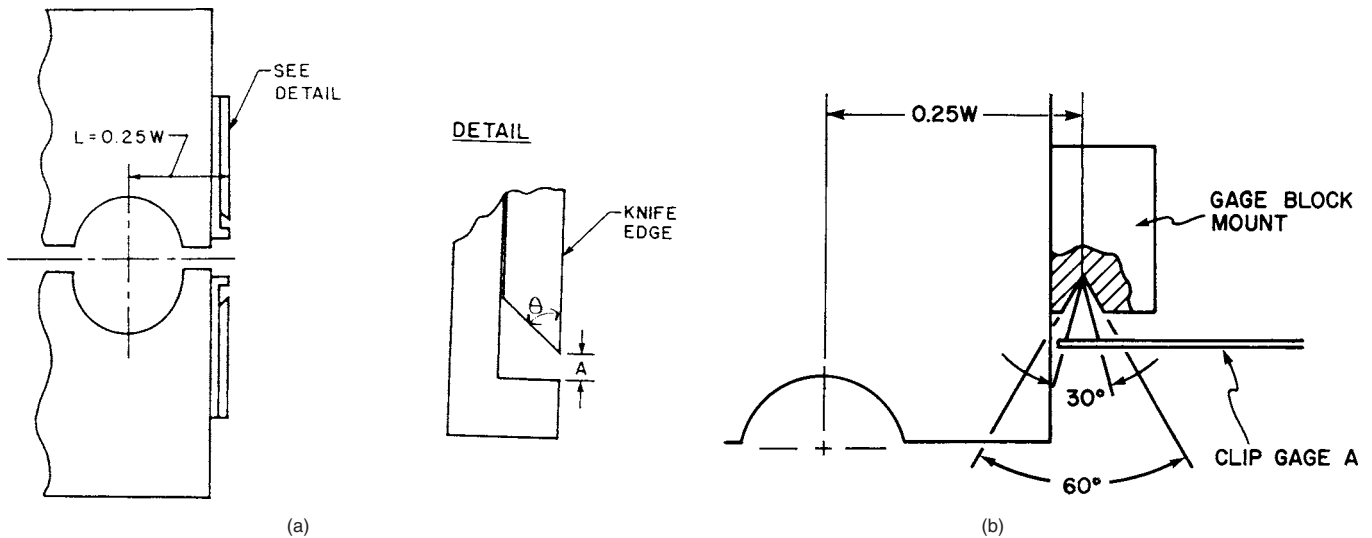

NOTE 1— Dimension A should be 0.002–0.010 in. (0.05–0.25 mm) less than the thickness of the clip gage arm.
 NOTE 2—The knife edge can be attached to the specimen with mechanical fasteners or adhesives.
 NOTE 3—The clip gage is installed by sliding it into the gap.

FIG. 4 Two Alternative Clip Gage Seating Arrangements Using (a) Knife Edges and (b) Using Conical Mounts

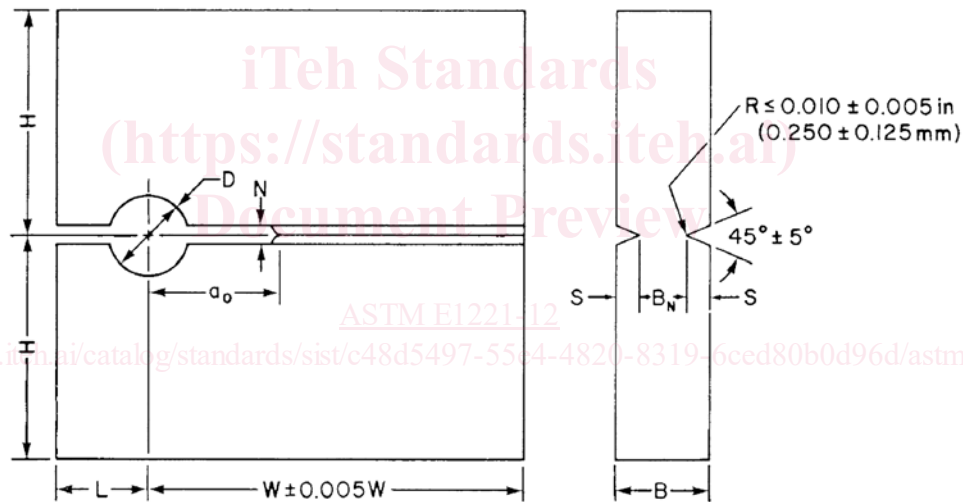

$$\begin{aligned}
 H &= 0.6 W \pm 0.005 W \\
 S &= (B - B_N)/2 \pm 0.01 B \\
 N &\leq W/10 \\
 0.15 W &\leq L \leq 0.25 W \\
 0.20 W &\leq a_o \leq 0.40 W \\
 0.125 W \pm 0.005 W &\leq D \leq 0.250 W \pm 0.005 W
 \end{aligned}$$

FIG. 5 Geometry and Dimensions of a Crack-Line-Wedge-Loaded Compact-Crack-Arrest (CCA) Test Specimen that is Satisfactory for Low and Medium Strength Steels

seating of the load train and clip gage, local cracking in the brittle weld, and interference with crack closure due to incomplete strain reversal in the plastic zone near the root of the starter notch. The purpose of the cyclic loading technique is to identify and estimate the magnitude of these contributions.

8.4.3 The effects of load train seating and weld bead cracking can essentially be limited to the first loading cycle by an appropriate limit on the maximum opening displacement imposed in that cycle. This limit is designed to keep the first

loading cycle linear elastic in a global sense. These influences can then be eliminated, with some degree of conservatism, by excluding the zero-force displacement offset recorded at the end of the first loading cycle from the displacement used to calculate K_{Ia} .

8.4.4 The second undesirable contribution to the total measured crack opening displacement is due to the local yielding that occurs around the root of the starter notch prior to initiation of a rapid fracture. The formation and growth of this

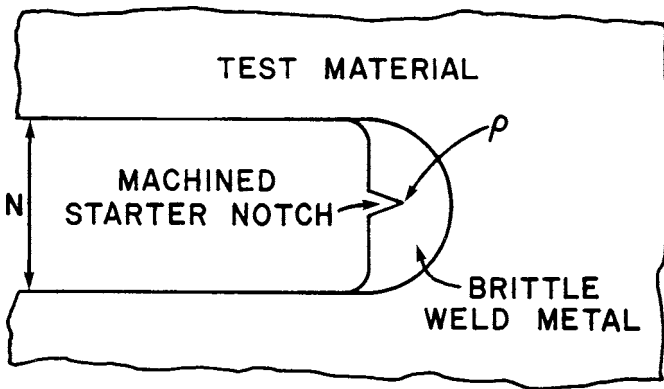

NOTE 1—Dimension N must be large enough to allow entry of the welding electrode being used.

FIG. 6 Details of the Notched Brittle Weld that is Recommended for Use as a Crack Starter for Low and Medium Strength Steels

plastic zone can be regarded as being mainly responsible for the zero-force displacement offsets that are recorded after completion of the first loading cycle, that is, between Cycles 2 and 3, 3 and 4, etc. The influence of this effect could be eliminated in its entirety by excluding all of the zero-force offset in opening displacement measured prior to the start of the loading cycle during which the run-arrest event occurs. However, there is evidence to suggest that such a step may be overly conservative. Model tests have shown that, when the plastic zone is well enclosed by the linear elastic stress field in the specimen, nearly all of the offset in the zero-force displacement is recovered if the plastic zone is severed by a saw cut or by a brittle crack (9). The degree to which this component of the strain energy stored in the specimen is recovered in time to influence the run-arrest behavior of the rapid crack is unclear at the present time. The K -calculation procedure of this test method therefore avoids the extremes of excluding all or none of the zero-force displacement offsets which accumulate in the second and subsequent loading cycles, and excludes one half of these effects.

8.4.5 An autographic record of wedge-force versus crack-mouth-opening-displacement should be obtained. The recorder should not be re-zeroed between loading cycles since knowledge of the accumulated zero-force displacement offset is desired. It could also be useful to obtain information about the final segment of the opening-displacement versus time record on an oscillograph or other high-rate recording device. This would provide additional information about the nature of the run-arrest event.

8.4.6 Apply force to the wedge until the crack-mouth-opening-displacement measured by the clip gage reaches the recommended maximum value given by:

$$[(\delta_o)_1]_{\max} = \frac{0.69 \sigma_{YS} W \sqrt{B_N/B}}{E f(a_o/W)} \quad (1)$$

where:

σ_{YS} = static yield strength of the specimen material (or, in the case of the duplex specimen, of the crack-starter-section material).

The other terms are as defined in 9.2. The testing machine should be operated in displacement control, with a free-running crosshead speed of 2 to 12 mm/min (0.1 to 0.5 in./min).

NOTE 2—Rapid fracture initiation on the first loading cycle is unlikely in the brittle weld CCA specimen. However, if a run-arrest event does occur, proceed with the calculations of K_o and K_a in the same manner as if sequential load-unload cycling had been used. In subsequent tests of replicate specimens, the first cycle displacement limit should be reduced sufficiently so that the first loading cycle can be completed without intervention of a rapid fracture.

8.4.7 Unload the specimen by extracting the wedge in preparation for a second loading cycle. The clip gage should remain in place during unloading and wedge removal to maintain a record of the displacement offset that occurs upon a return to zero force.

NOTE 3—Wedge extraction and cyclic loading can be simplified greatly by the use of the arrangement shown schematically in Fig. 7. Key features include a hold-down plate and a wedge that is fastened to the loading ram. However, the hold-down plate may not be required when using lubricant in the form of TFE-fluorocarbon strips (see 6.2.1.1).

8.4.8 Without re-zeroing the recorder, reinsert and apply force to the wedge at the same displacement rate as on the first cycle. Continue loading until a rapid crack jump occurs or until the displacement measured with the clip gage reaches a predetermined value. The recommended maximum opening displacement on the second and subsequent cycles can be calculated from

$$[(\delta_o)_n]_{\max} = [1.0 + 0.25(n - 1)] \left[\frac{0.69 \sigma_{YS} W \sqrt{B_N/B}}{E f(a_o/W)} \right] \quad (2)$$

where:

n = cycle number.

The other terms are the same as in (Eq 1). If an unstable crack is not initiated upon reaching the prescribed displacement limit, again unload and extract the wedge as specified in 8.4.7. Label the force/displacement record with the appropriate cycle number and repeat 8.4.8.

NOTE 4—If a large number of load/unload cycles are required, it may be necessary to relubricate the wedge and split-pin assembly. Increased friction will be indicated by an increased slope in the force-displacement record and the need for large reverse loads to extract the wedge.

8.4.9 To measure K_a , a segment of unstable crack extension must occur. The occurrence of unstable crack extension will normally be apparent to the operator, both audibly and as an abrupt force drop on the test record. (In the brittle weld CCA specimen, a force drop of 50 to 60 % has been found to indicate that a sufficient length of unstable fracturing has occurred.) After the event, the operator should remove the force on the wedge to avoid further crack propagation.

8.4.10 If on subsequent loading cycles, it is observed that attempts to increase the opening displacement are accompanied by a decrease in the applied wedge load, that is, stable tearing is occurring, it is unlikely that the specimen will exhibit rapid run-arrest fracturing. It is recommended that under these circumstances, the test be discontinued. It may be helpful at this point to remachine the specimen to remove the weld bead and the material ahead of the starter notch that has been subjected to plastic deformation. A fresh starter notch can then

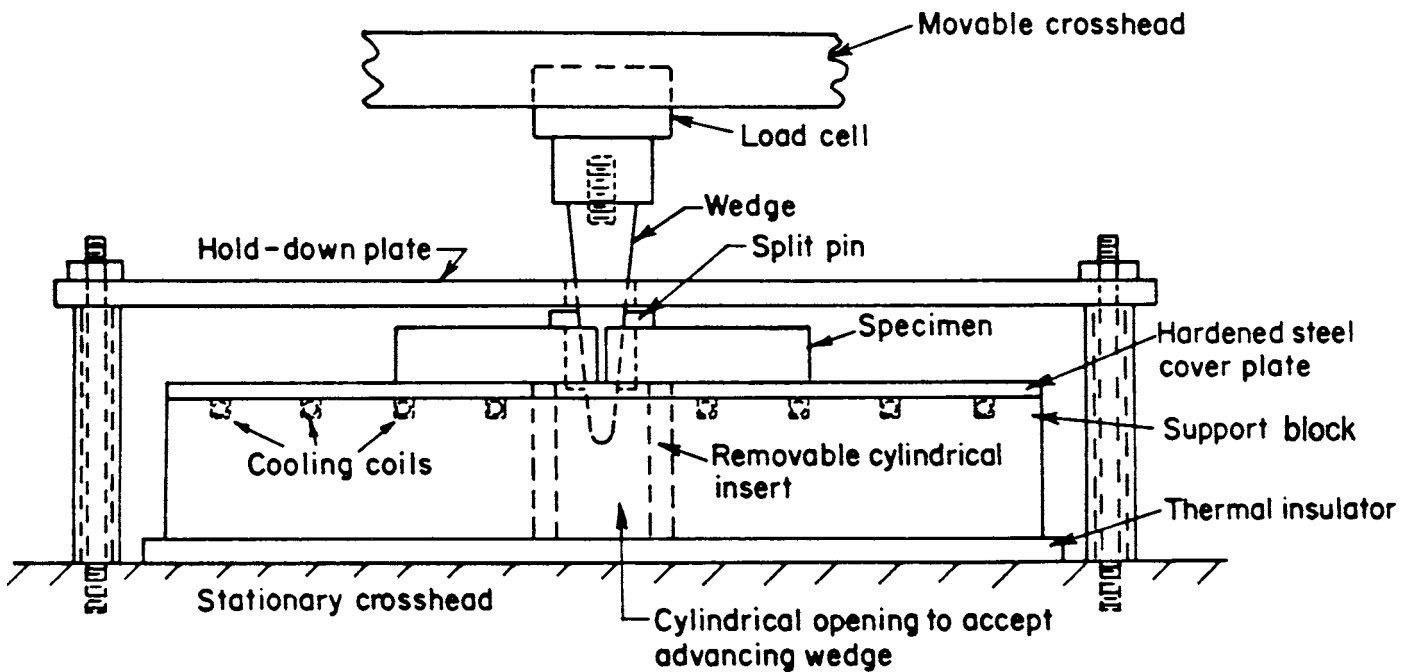

FIG. 7 Schematic Illustration of a Loading Arrangement that Facilitates Wedge Extraction When Using the Cyclic Loading Technique

be prepared and the specimen retested at a lower temperature (20 to 40°C (35 to 70°F) lower) in an attempt to obtain useful data from the specimen.

NOTE 5—A displacement limit beyond which the specimen is unlikely to give successful results can be estimated from the following equation:

$$[\delta_o]_{\text{limit}} = \frac{1.50 \sigma_{ys} W \sqrt{B_N/B}}{E f(a_o/W)} \quad (3)$$

which is approximately twice the quantity calculated from (Eq 1).

NOTE 6—The quantity of material that must be removed from an unsuccessful specimen can be approximated by the radius of the plastic zone surrounding the starter notch under plane strain conditions, and calculated from $(K_o/\sigma_{ys})^2/6\pi$. A sufficient quantity of material must be machined out to remove any stable tearing that may have occurred.

8.5 Marking the Arrested Crack:

8.5.1 The position of the arrested crack can be marked by heat tinting. Heating at temperatures in the range 260 to 370°C (500 to 700°F) for 10 to 90 min has proved successful. Any time and temperature combination that clearly marks the arrested crack front is acceptable. The appearance of heat tinting on freshly machined (or ground and sanded) surfaces may provide a clue to the heat tinting progress on the fracture surfaces. If a fractographic examination of the fracture surfaces is to be performed, the use of lower heat tinting temperatures or the marking of the arrested crack front by means of fatigue may be desirable.

8.5.2 After marking the crack front the specimen is broken completely in two. This can usually be done with the wedging apparatus used in testing the specimen. The breaking open of structural steel specimens is greatly facilitated by cooling them in dry ice or liquid nitrogen.

8.6 Measurement of Arrested Crack Size:

8.6.1 The heat-tinted fracture surface should first be examined to determine whether it displays irregularities serious enough to warrant exclusion of the test result. The occurrence of tunnelling, a failure to follow the side grooves on one or both sides, and the presence of large, unbroken ligaments on the fracture surface are all behaviors that may give erroneous results for K_a . Annex A1 provides more detailed information on this subject.

8.6.2 The average of three measurements defines the arrested crack size, a_a . These measurements are to be made on the heat-tinted fracture surface, to within 1 %, at the following positions: at the center (mid-thickness) of the specimen, and midway between the center and the bottom of the side groove on each side. Since crack front irregularities may make it difficult to determine the crack length at the specified locations, it is suggested that the measurement be taken as a visual average across a strip of width, $B_N/4$, centered at each measurement location. Examples of sample crack size determinations using this technique are also provided in Annex A1.

NOTE 7—It is recommended that a photographic record of the heat-tinted fracture surface be made a part of the test report, particularly if there are any unusual perturbations in the crack front contours. Descriptive comments may also be helpful.

9. Calculation and Interpretation of Results

9.1 Displacement Measurement:

9.1.1 From the autographic force-displacement record, several displacement values should be determined. Fig. 8 is a typical force-displacement record for a specimen tested using sequential load-unload cycling that did not exhibit unstable cracking until the fourth loading cycle. The required displacements are as follows:

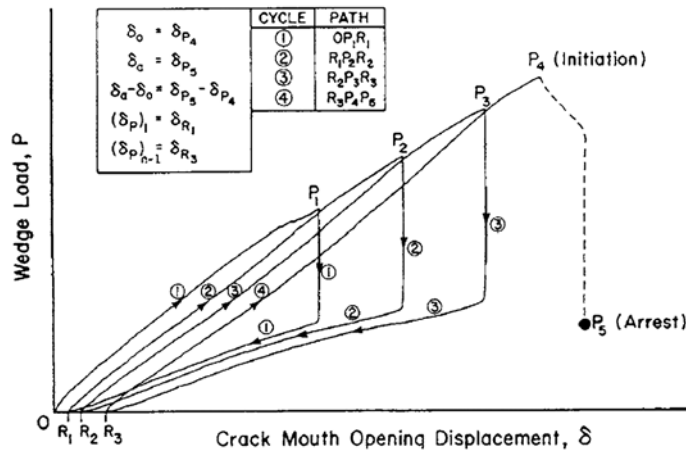

FIG. 8 Wedge-Force Versus Crack-Mouth-Opening-Displacement Record for a Specimen Tested Using Cyclic Loading Techniques, that Displayed Rapid Run-Arrest Fracturing on the Fourth Loading Cycle

TABLE 1 Values of $f(x)$ for use in (Eq 4)

x	f(x)	x	f(x)	x	f(x)
0.20	0.390	0.42	0.223	0.64	0.149
0.21	0.378	0.43	0.218	0.65	0.147
0.22	0.367	0.44	0.214	0.66	0.144
0.23	0.357	0.45	0.210	0.67	0.141
0.24	0.347	0.46	0.206	0.68	0.139
0.25	0.337	0.47	0.202	0.69	0.136
0.26	0.328	0.48	0.198	0.70	0.133
0.27	0.319	0.49	0.194	0.71	0.131
0.28	0.310	0.50	0.191	0.72	0.128
0.29	0.302	0.51	0.188	0.73	0.125
0.30	0.294	0.52	0.184	0.74	0.122
0.31	0.287	0.53	0.181	0.75	0.119
0.32	0.280	0.54	0.178	0.76	0.117
0.33	0.273	0.55	0.175	0.77	0.114
0.34	0.266	0.56	0.172	0.78	0.111
0.35	0.260	0.57	0.169	0.79	0.108
0.36	0.254	0.58	0.166	0.80	0.105
0.37	0.248	0.59	0.163	0.81	0.102
0.38	0.243	0.60	0.160	0.82	0.098
0.39	0.237	0.61	0.158	0.83	0.095
0.40	0.232	0.62	0.155	0.84	0.092
0.41	0.227	0.63	0.152	0.85	0.088

- 9.1.1.1 $(\delta_p)_1$ = displacement offset at the end of the first load cycle = δ_{R1} in Fig. 8;
- 9.1.1.2 $(\delta_p)_{n-1}$ = total displacement offset at the end of the $(n-1)$ cycle = total displacement offset at the start of the last cycle = δ_{R3} in Fig. 8;
- 9.1.1.3 δ_o = displacement at the onset of unstable crack growth = δ_{P4} in Fig. 8;
- 9.1.1.4 δ_a = displacement approximately 0.1 s after crack arrest = δ_{P5} in Fig. 8;
- 9.1.1.5 $\delta_a - \delta_o$ = rapid increase in crack opening that frequently accompanies the run-arrest event = $\delta_{P5} - \delta_{P4}$ in Fig. 8.

NOTE 8—The preferred interpretation of δ_a is the opening displacement at about 2 ms after crack arrest. However, this measurement may not be possible with the instrumentation used. This testing practice assumes that δ_a at about 100 ms after crack arrest does not differ significantly from δ_a at 2 ms.

9.1.2 In the brittle weld CCA specimen, a force drop of 50 to 60 % has been found to indicate that a sufficient length of unstable fracture has occurred and that δ_a is a usable arrest displacement value. See 9.3.2 and 9.3.4 for limitations on the length of the run-arrest segment.

9.2 Calculation of K_o and K_{Qa} :

9.2.1 Calculate K_o and K_{Qa} from the following:

$$K = E \delta f(x) \frac{\sqrt{B/B_N}}{\sqrt{W}} \text{ MPa}\sqrt{\text{m}} \text{ (ksi}\sqrt{\text{in.}}) \quad (4)$$

where:

$$f(x) = (1-x)^{0.5} (0.748 - 2.176x + 3.56x^2 - 2.55x^3 + 0.62x^4) \text{ and} \quad (5)$$

$$x = a/W.$$

9.2.2 The expression for $f(x)$ used here is based on a curve fit to boundary value collocation results and an exact limit solution (10). The curve fit is considered to be accurate within 1 % over the range $0.20 \leq x \leq 1$, and is in close agreement with experimental compliance results (11). Values of $f(x)$ computed from (Eq 5) for various values of x are given in Table 1. The other terms in (Eq 4) are as follows:

- E = Young's modulus, MPa (ksi),
- a = initial slot size, a_o , or final crack size, a_a , as determined in 8.6, m (in.),
- W = specimen width, m (in.),
- B = specimen thickness as shown in Fig. 5, m (in.),
- B_N = specimen thickness at crack plane as shown in Fig. 5, m (in.), and
- δ = crack mouth opening displacement, m (in.).

9.2.3 To calculate K_o , use $a = a_o$ and $\delta = d_o$. To calculate K_a , use $a = a_a$ and $\delta = d_a$. The quantities d_o and d_a are given as follows:

$$d_o = \delta_o - (\delta_p)_{n-1}, \text{ and} \quad (6)$$

$$d_a = \delta_o - (\delta_p)_1 - 0.5[(\delta_p)_{n-1} - (\delta_p)_1] + 0.5[\delta_a - \delta_o] \quad (7)$$

$$= 0.5[\delta_o + \delta_a - (\delta_p)_1 - (\delta_p)_{n-1}] \quad (8)$$

NOTE 9—The quantities in brackets in (Eq 7) both represent displacement components whose exact contribution to the energy available to drive the running crack is unclear at the present time. The rationale for the

selection of the premultiplier of 0.5 for each of these quantities is discussed in Ref (2). (Eq 8) is simply a mathematical simplification of (Eq 7) and may be more convenient to use from a computational standpoint.

NOTE 10—If a rapid run-arrest event occurs on the first loading cycle, (Eq 8) should be used with $(\delta_p)_{n-1}$ and $(\delta_p)_1$ set equal to zero.

9.3 Validity Requirements:

9.3.1 The value of K_{Qa} calculated from (Eq 4) can be considered a linear-elastic plane-strain value, K_{Ia} , provided the criteria described in 9.3.2-9.3.4 and summarized in Table 2 are satisfied. Comments on the adequacy of these requirements can be found in Refs (2) and (12). It should also be pointed out that in some instances, the extrapolation of a combined set of test results, including some which would be deemed invalid by these criteria, may be useful in predicting the behavior of large structures.

9.3.1.1 Use is made in the following of σ_{Yd} , a formal dynamic yield strength estimate for appropriate loading times at the test temperature. For structural steels, it is being assumed here that σ_{Yd} is 205 MPa (30 ksi) greater than the yield strength, σ_{YS} , measured by Test Methods E8.

NOTE 11—The extremely high strain rates associated with yielding near the tip of a fast running crack and the abrupt nature of crack arrest suggest that the true elevation of σ_{Yd} over σ_{YS} should be much greater. The value of σ_{Yd} that is being used here is therefore thought to substantially underestimate the actual effective resistance to plastic flow at crack arrest (12).

9.3.2 The unbroken ligament, $W - a_a$, must equal or exceed both 0.15W and $1.25 (K_{Qa} / \sigma_{Yd})^2$.

9.3.3 The thickness, B , must equal or exceed $1.0 (K_{Qa} / \sigma_{Yd})^2$.

9.3.4 The minimum crack jump, $a_a - a_o$, must be at least twice the slot width, N , defined in Fig. 5, and greater than the plane-stress plastic zone radius associated with the initial loading, $(K_o / \sigma_{YS})^2 / 2\pi$.

NOTE 12—If a duplex specimen is used, the alternative requirement is that the crack penetrate a distance equal to or greater than B_N into the test section.

10. Report

10.1 Report the following information:

10.1.1 Test Identification:

10.1.1.1 Date,

10.1.1.2 Specimen number, and

10.1.1.3 Crack plane orientation in accordance with Terminology E1823.

10.1.2 Material:

10.1.2.1 Material type,

10.1.2.2 Young's modulus,

10.1.2.3 Yield strength (offset – 0.2 %) as determined by Test Methods E8, and

TABLE 2 Summary of Criteria Used to Ensure That K_{Qa} is a Linear Elastic, Plane-Strain Value

Feature	Criterion
Unbroken ligament	(A) $W - a_a \geq 0.15W$
Unbroken ligament	(B) $W - a_a \geq 1.25 (K_a / \sigma_{Yd})^2$
Thickness	(C) $B \geq 1.0 (K_a / \sigma_{Yd})^2$
Crack-jump length	(D) $a_a - a_o \geq 2N$
Crack-jump length	(E) $a_a - a_o \geq (K_o / \sigma_{YS})^2 / 2\pi$

10.1.2.4 Dynamic yield strength used in 9.3.2 and 9.3.3.

10.1.3 Test Temperature:

10.1.4 Starter Notch:

10.1.4.1 Type of brittle weld, if any,

10.1.4.2 Notch width, N , and

10.1.4.3 Notch root radius, ρ .

10.1.5 Specimen Dimensions:

10.1.5.1 Specimen thickness, B ,

10.1.5.2 Specimen thickness at crack plane, B_N ,

10.1.5.3 Thickness ratio, B_N / B , and

10.1.5.4 Width, W .

10.1.6 Crack Size Measurements:

10.1.6.1 Method used for marking the arrested crack front,

10.1.6.2 Crack size at machined notch, a_o , and

10.1.6.3 Crack size at arrest,

(1) At mid-thickness, a_2 ,

(2) At ¼ points of net thickness, a_1 and a_3 , and

(3) Average crack size at arrest, $a_a = (a_1 + a_2 + a_3) / 3$.

10.1.7 Test Record:

10.1.7.1 Force and displacement records and associated calculations,

10.1.7.2 First cycle limiting displacement, $[(\delta_o)_1]_{\max}$,

10.1.7.3 Opening displacement increment for subsequent cycles, $(\delta_o)_{\text{inc}} = 0.25 [(\delta_o)_1]_{\max}$,

10.1.7.4 Number of load/unload cycles, n ,

10.1.7.5 Displacements measured from force-displacement records,

(1) Displacement offset at end of first loading cycle, $(\delta_p)_1$,

(2) Total displacement offset accumulated prior to start of

last loading cycle, $(\delta_p)_{n-1}$,

(3) Displacement at onset of unstable crack growth, δ_o ,

(4) Displacement at crack arrest, δ_a , and

(5) Displacement increase accompanying the run-arrest event, $\delta_a - \delta_o$,

10.1.7.6 Displacements used to calculate K_o and K_{Qa} ,

(1) Displacement used to calculate K_o , d_o according to Eq 6

(2) Displacement used to calculate K_a , d_o according to Eq 7 or Eq 8.

10.1.7.7 Force drop as a percentage of P_{\max} ,

10.1.8 Calculated Values of K_o and $K_{Qa} (K_{Ia})$:

10.1.8.1 K_o , and

10.1.8.2 $K_{Qa} (K_{Ia})$.

10.1.9 Validity Requirements (see Table 2):

10.1.9.1 Uncracked ligament length,

(1) Compared to 0.15W, and

(2) Compared to $1.25 (K_{Qa} / \sigma_{Yd})^2$,

10.1.9.2 Thickness, compared to $1.0 (K_{Qa} / \sigma_{Yd})^2$,

10.1.9.3 Crack jump length,

(1) Compared to 2N, and

(2) Compared to $(K_o / \sigma_{YS})^2 / 2\pi$.

10.1.10 Photographic Record of Fracture Surfaces and Descriptive Comments (Optional):

11. Precision and Bias

11.1 Precision:

11.1.1 The precision of a K_{Ia} determination by this test method is a function of the precision and bias of the various measurements of linear dimensions of the specimen and testing

fixtures, the precision of the displacement measurements, the precision and bias of the recording devices used to produce the force displacement record, and the precision and bias of the measurements of the arrested crack size. It is not possible to make meaningful statements concerning precision and bias for all of these measurements. However, it is possible to derive useful information concerning the precision of a K_{Ia} measurement in a global sense from the results of an interlaboratory round-robin test program that was conducted to evaluate the originally proposed test method on which this test method is based (2).⁵

11.1.2 The results from this program are summarized in Table 3. It should be appreciated that the measures of precision shown in Table 3 apply to tests conducted with materials that exhibit strong transitional behavior in terms of temperature. A larger degree of scatter in K_{Ia} measurements could therefore be expected in tests conducted higher in the transition range, although the coefficient of variation appears to be temperature insensitive for some materials (6). The materials tested also exhibit significant inhomogeneity, and a size effect may be apparent when testing specimens of different sizes, with tests

⁵ Information on K_{Ia} round-robin data and the round-robin program is available in Ref (2), a copy of which is available from ASTM Headquarters. Request RR:E8-1003.

TABLE 3 Grand Means and Standard Deviations for K_{Ia} for Three Steels as Obtained From a Large Interlaboratory Round Robin Test Program^A

Material Tested	A514 ^B	A588 ^C	A533B ^D	A533B ^D
Test Temperature	-30°C	-30°C	10°C	25°C
No. of Test Results	12	40	30	28
Mean K_{Ia} , MPa \sqrt{m}	88.4	61.5	78.2	83.4
Standard Deviation, MPa \sqrt{m} and percent	10.2 (12 %)	6.4 (10 %)	9.7 (12 %)	10.6 (13 %)

^A A total of 21 laboratories reported test results from the program.

^B Specimens were cut from 50.8 mm (2-in.) thick rolled plate and tested full thickness in an L-T orientation; σ_{YS} = 890 MPa (129 ksi); NDT = -50°C (-58°F); RT_{NDT} = -12°C (10°F).

^C Specimens were cut from 50.8-mm (2-in.) thick rolled plate and tested full thickness in an L-T orientation; σ_{YS} = 330 MPa (48 ksi); NDT = -10°C (14°F); RT_{NDT} = -9°C (16°F).

^D Specimens of 50.8-mm (2-in.) thickness were cut from 254mm (10-in.) thick rolled plate and tested in an L-S orientation; σ_{YS} = 480 MPa (70 ksi); NDT = -12°C (10°F); RT_{NDT} = -2°C (28°F).

on smaller specimens being characterized by larger scatter than tests on larger specimens.

11.2 *Bias*—There is no accepted standard value for the plane-strain crack-arrest fracture toughness of any material. In the absence of such a true value, any statement concerning bias is not meaningful.

iTech Standards
(<https://standards.iteh.ai>)
ANNEX
(Mandatory Information)

A1. GUIDELINES FOR ASSESSING FRACTURE SURFACE ACCEPTABILITY AND PROCEDURES FOR DETERMINING THE ARRESTED CRACK SIZE

A1.1 Introduction:

A1.1.1 The idealized fracture surface of a crack arrest specimen is flat, continuous, and straight-fronted. This idealization can be closely approached in practice, as evidenced by Fig. A1.1 and Fig. A1.2. However, the fracture surfaces of crack-arrest specimens can be complicated by features that, when present in excess, can lead to questionable results for the crack-arrest fracture toughness of the material being tested. This annex provides guidelines for identifying, from the fracture surface appearance, test results that are probably not representative of the bulk of the material being tested. It also provides guidelines for determining the arrested crack size, a_a , for a specimen with an irregular crack front.

A1.1.2 Deviations from the ideal fracture surface appearance generally fall into three broad categories. These are: the presence of remaining ligaments, a lack of crack front straightness, and crack propagation out of the plane of the side grooves. The extent to which one or more of these behaviors can occur without adversely affecting the test result cannot be easily quantified at the present time. The purpose of this annex is to provide a basis for the decision-making process that is required in assessing fracture surface acceptability and it is

intended to serve as a set of guidelines for the personnel involved in obtaining crack-arrest toughness data.

A1.1.3 The final decision as to which fracture surfaces will be classified as unacceptable presently rests primarily on the judgment of the individual (or individuals) performing and evaluating the test. This judgement should be based on experience, or on some knowledge of what is representative for the particular steel and test temperature combination under consideration. Judgmental decisions of this nature are clearly undesirable from a standards viewpoint. However, the alternative would be to disregard test results from all specimens with any degree of fracture surface irregularity. This would not only reduce the percentage of successful, valid tests to a very small number, but would also eliminate virtually all tests performed under certain conditions, for example, at temperatures well into the transition range for a given material. As the testing technology involved here matures, it is anticipated that this annex will be updated to a more quantitative level.

A1.2 Fracture Surface Acceptability:

A1.2.1 Remaining Ligaments:

A1.2.1.1 In a number of steels, portions of the surface formed by a rapid fracture frequently remain unbroken. These