



Designation: C952 – 12

Standard Test Method for Bond Strength of Mortar to Masonry Units¹

This standard is issued under the fixed designation C952; the number immediately following the designation indicates the year of original adoption or, in the case of revision, the year of last revision. A number in parentheses indicates the year of last reapproval. A superscript epsilon (ϵ) indicates an editorial change since the last revision or reapproval.

This standard has been approved for use by agencies of the U.S. Department of Defense.

1. Scope*

1.1 This test method provides two procedures for measuring bond strength of mortar to masonry units: a crossed brick couplet tensile test for evaluating mortar-brick bond strength and a stacked-bond, flexural test for evaluating mortar-concrete block bond strength.

1.2 The values stated in inch-pound units are to be regarded as standard. The values given in parentheses are mathematical conversions to SI units that are provided for information only and are not considered standard.

1.3 *This standard does not purport to address the safety concerns, if any, associated with its use. It is the responsibility of the user of this standard to establish appropriate safety and health practices and determine the applicability of regulatory limitations prior to use.*

2. Referenced Documents

2.1 *ASTM Standards:*²

- C67 Test Methods for Sampling and Testing Brick and Structural Clay Tile
- C90 Specification for Loadbearing Concrete Masonry Units
- C129 Specification for Nonloadbearing Concrete Masonry Units
- C140 Test Methods for Sampling and Testing Concrete Masonry Units and Related Units
- C270 Specification for Mortar for Unit Masonry
- C780 Test Method for Preconstruction and Construction Evaluation of Mortars for Plain and Reinforced Unit Masonry
- C1072 Test Methods for Measurement of Masonry Flexural Bond Strength

¹ This test method is under the jurisdiction of ASTM Committee C15 on Manufactured Masonry Units and is the direct responsibility of Subcommittee C15.04 on Research. Committee E-6 maintains a continued interest in these practices and will make use of them in the future.

Current edition approved June 1, 2012. Published July 2012. Originally approved in 1959. Last previous edition approved in 2009 as C952 – 02 (2009). DOI: 10.1520/C0952-12.

² For referenced ASTM standards, visit the ASTM website, www.astm.org, or contact ASTM Customer Service at service@astm.org. For *Annual Book of ASTM Standards* volume information, refer to the standard's Document Summary page on the ASTM website.

C1437 Test Method for Flow of Hydraulic Cement Mortar
E518 Test Methods for Flexural Bond Strength of Masonry

3. Significance and Use

3.1 These procedures are useful for research into bond strength of masonry. They are not intended to predict the bond strength of commercial masonry construction. The bond strength in commercially built structures is determined by many factors beyond the characteristics of mortar, masonry units, and the procedures of this test method.

NOTE 1—The crossed-brick couplets method measures a direct tensile strength of the bond between the mortar and masonry unit. It does not determine the flexural strength of the unit mortar assembly. Other test methods may be more appropriate for determining the flexural bond strength between mortar and masonry units. These include Test Methods C1072 and Test Methods E518.

PREPARATION AND TESTING OF FRESH MORTAR

4. Preparation of Mortar

4.1 Proportion mortar materials by weights equivalent to volume proportions to be used in prism construction. Use unit weights for individual materials as given in Specification C270. Sand shall be permitted to be used in a damp loose condition, provided that moisture content of sand is determined with reference to the oven-dried condition and batch proportions are adjusted accordingly. Record weight of ingredients (including water) added to the batch of mortar.

4.2 Mix mortar in a mechanical paddle-type mortar mixer. Time periods referenced below are measured from when water and cementitious materials are combined.

4.2.1 Add an estimated amount of water to the mortar to achieve the desired consistency (Note 2). Mix mortar for three minutes and determine consistency. If the desired consistency is specified by flow determine it in accordance with Test Method C1437. If the desired consistency is specified as initial cone penetration, determine it in accordance with Test Method C780. Once consistency is recorded, return the material used to measure the consistency to the mixer. If the consistency is within the desired range, continue mixing the batch for an additional two minutes. If the consistency is less than the desired range, add water to the batch and mix for one minute and determine consistency. Once consistency is recorded,

*A Summary of Changes section appears at the end of this standard

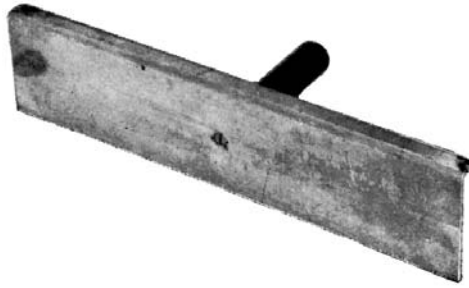

FIG. 1 Splash Board

return the material used to measure consistency to the mixer. If the consistency is within the desired range, continue mixing the batch for one minute.

NOTE 2—Workable consistency of mortar for concrete masonry construction generally requires an initial cone penetration reading of 55 ± 5 mm or a flow of $125 \pm 5\%$. Workable consistency of mortar for clay masonry construction generally requires an initial cone penetration reading of 65 ± 5 mm or a flow of $135 \pm 5\%$. Optimum consistency for a specific mortar-unit combination may differ from these values.

4.2.2 If after the one-time addition of water the consistency is not in the desired range, discard the batch.

4.2.3 If the measured consistency exceeds the desired range at any time, discard the batch.

4.3 Immediately after mixing the mortar, determine its initial cone penetration in accordance with Test Method C780. Determine the cone penetration of the mortar every 15 ± 5 minutes. If the cone penetration is less than 80 % of its initial value, discard the remaining portion of the mortar without constructing additional mortar joints.

PREPARATION AND TESTING OF BOND STRENGTH TEST SPECIMENS

5. Apparatus

5.1 *Miscellaneous*— Brass-covered mortar board 18 in. (457 mm) square, an 11-in. (279-mm) long mason's trowel, laboratory trowel with straight edges, short handled spoon or scoop of $\frac{1}{4}$ -cup (0.5-dm^3) capacity, steel straightedge 10 in. (254 mm) long, metal mold $\frac{1}{2}$ in. (13 mm) deep with $3\frac{5}{8}$ -in. (92-mm) square opening beveled to slope of 0.08 (total 0.04), splash board (Fig. 1) with handle 20 in. (508 mm) long and 3 in. (76 mm) wide.

5.2 *Drop Hammer* for crossed-brick couplets (Fig. 2, Table 1).

5.3 *Drop Hammer* for block assemblies (Fig. 3).

5.4 *Loading Jigs* for crossed-brick couplets (Fig. 4).

5.5 *Frames* (Fig. 5) for testing block assemblies: upper frame fitted with ball bearing mounted 10 in. (254 mm) from vertical axis of specimen for eccentric application of vertical load.

5.6 *Torque Wrench*.

6. Crossed-Brick Couplets

6.1 *Brick*—Test specimens consisting of crossed-brick couplets may be used to determine:

6.1.1 Bond between specified brick and a specified mortar,

6.1.2 Relative bond between different brick and a specified mortar, or

6.1.3 Relative bond between a specified brick and different mortars.

6.1.4 In each case, the initial rate of absorption of the brick shall be determined in accordance with Test Methods C67. The brick used for couplets shall include the full range of absorption rates acceptable under the specifications.

6.2 Construction of Test Specimens :

6.2.1 Center the mold on the lower brick of the couplet and lightly mix a small quantity of mortar on the board by turning over with the spoon.

6.2.2 Half-fill the mold by sharply dashing into each corner and the center of the mold a small quantity of mortar from the half-filled spoon. Note the time at start of a 1-min interval. Apply additional mortar by heaping loosely with the spoon above the top of the mold. Strike off excess mortar with the straightedge, starting on a diagonal across the mold and working first to one corner and then to the opposite corner of the mold. Remove the mold from the mortar bed.

6.2.3 At the end of the 1-min time interval, place the upper brick on the mortar bed in a crosswise direction to the lower brick. Place the frame of the hammer on the top brick with the weight of the hammer held in the other hand. Drop the hammer in a frame a distance of $1\frac{1}{2}$ in. (38 mm).

6.2.4 Measure and record the extrusion of the mortar on the top surface of the lower brick. Cut away extruded mortar from all four edges of the mortar bed.

6.3 *Curing*—Promptly enclose the test specimen within an airtight covering. Keep covered for 7 days. Remove the cover and store until tested. Unless otherwise specified, the specimen shall be stored in laboratory air at a relative humidity of at least 50 %.

6.4 *Testing*—Center the specimen between the upper and lower tripods and place in the testing machine as shown in Fig. 6. Load the specimen at the rate of 600 lb (2.7 kN)/min or at a rate sufficient to cause failure in 1 to 2 min. Note and record maximum load and type of failure.

NOTE 3—The method of making the specimens typically produces a failure of the joint at the top of the mortar bed.

NOTE 4—Reproducibility of test results may be improved by the insertion of strips of high-density insulation board interlayers between the test specimen and test apparatus.

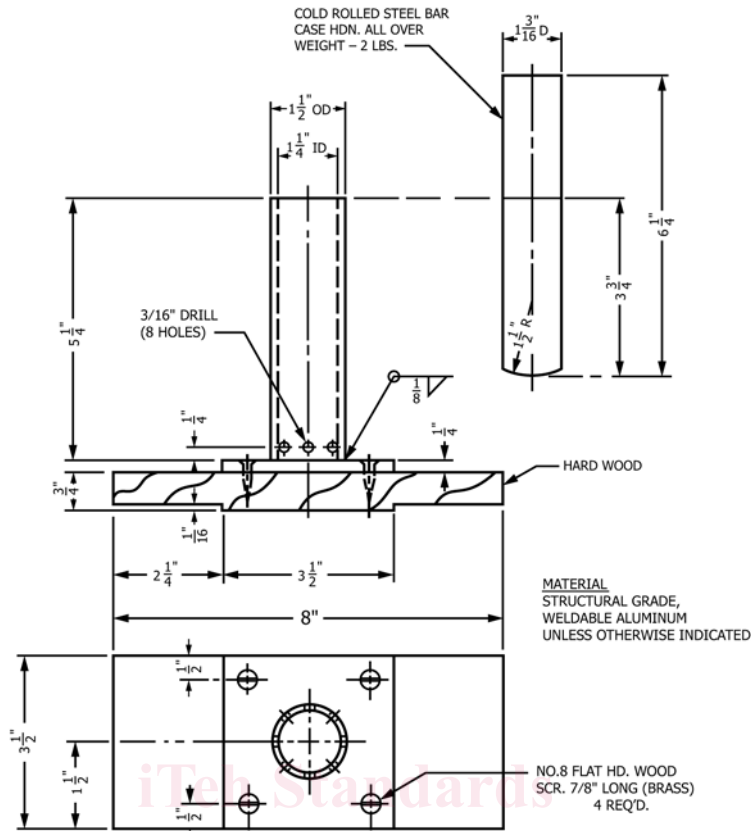

FIG. 2 Drop Hammer for Cross-Brick Couplets

TABLE 1 Metric Equivalents for Figs. 2, 3, 4, 5, and 6

Inch-Pound	Metric	Inch-Pound	Metric	Inch-Pound	Metric
1/16 in.	1.6 mm	1 3/4 in.	44 mm	5 in.	127 mm
1/8 in.	3 mm	1 7/8 in.	48 mm	5 1/4 in.	133 mm
3/16 in.	4.7 mm	2 in.	51 mm	5 3/4 in.	146 mm
1/4 in.	6.4 mm	2 1/8 in.	54 mm	6 in.	152 mm
5/16 in.	7.9 mm	2 1/4 in.	57 mm	6 1/4 in.	159 mm
3/8 in.	9.5 mm	2 3/8 in.	61 mm	7 1/2 in.	190 mm
7/16 in.	11 mm	2 1/2 in.	64 mm	8 in.	203 mm
1/2 in.	12.7 mm	2 5/8 in.	67 mm	8 1/2 in.	216 mm
5/8 in.	15.8 mm	3 in.	76 mm	9 3/4 in.	248 mm
3/4 in.	19 mm	3 1/8 in.	79 mm	10 3/4 in.	273 mm
7/8 in.	22 mm	3 1/4 in.	82 mm	16 in.	406 mm
1 in.	25 mm	3 1/2 in.	89 mm	16 1/2 in.	419 mm
1 1/8 in.	28 mm	3 5/8 in.	92 mm	18 3/4 in.	476 mm
1 1/16 in.	30 mm	3 3/4 in.	95 mm	28 in.	711 mm
1 1/4 in.	32 mm	4 in.	102 mm	2 lb	0.9 kg
1 3/8 in.	35 mm	4 1/4 in.	121 mm	3.5 lb	1.6 kg
1 1/2 in.	38 mm				

6.5 Calculation— Calculate the maximum tensile bond strength as follows:

$$\text{Tensile bond strength, } T, \text{ psi (or N/m}^2\text{)} = A/B \quad (1)$$

where:

- A = total applied load, lbf (or N), and
- B = cross-sectional area in bond, in.² (or m²).

7. Concrete Masonry Unit Assemblies

7.1 Concrete Masonry Units—Concrete masonry units used in test specimens shall conform to Specification C90 or C129. The moisture content of the concrete masonry units shall be as specified. In the absence of any other specified moisture content, the concrete masonry units shall be conditioned to

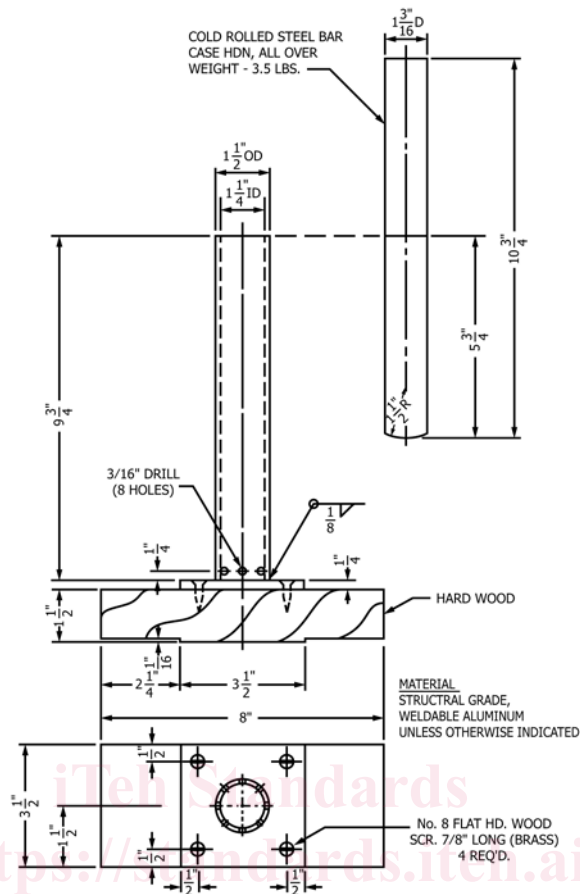

FIG. 3 Drop Hammer for Concrete Block Assemblies

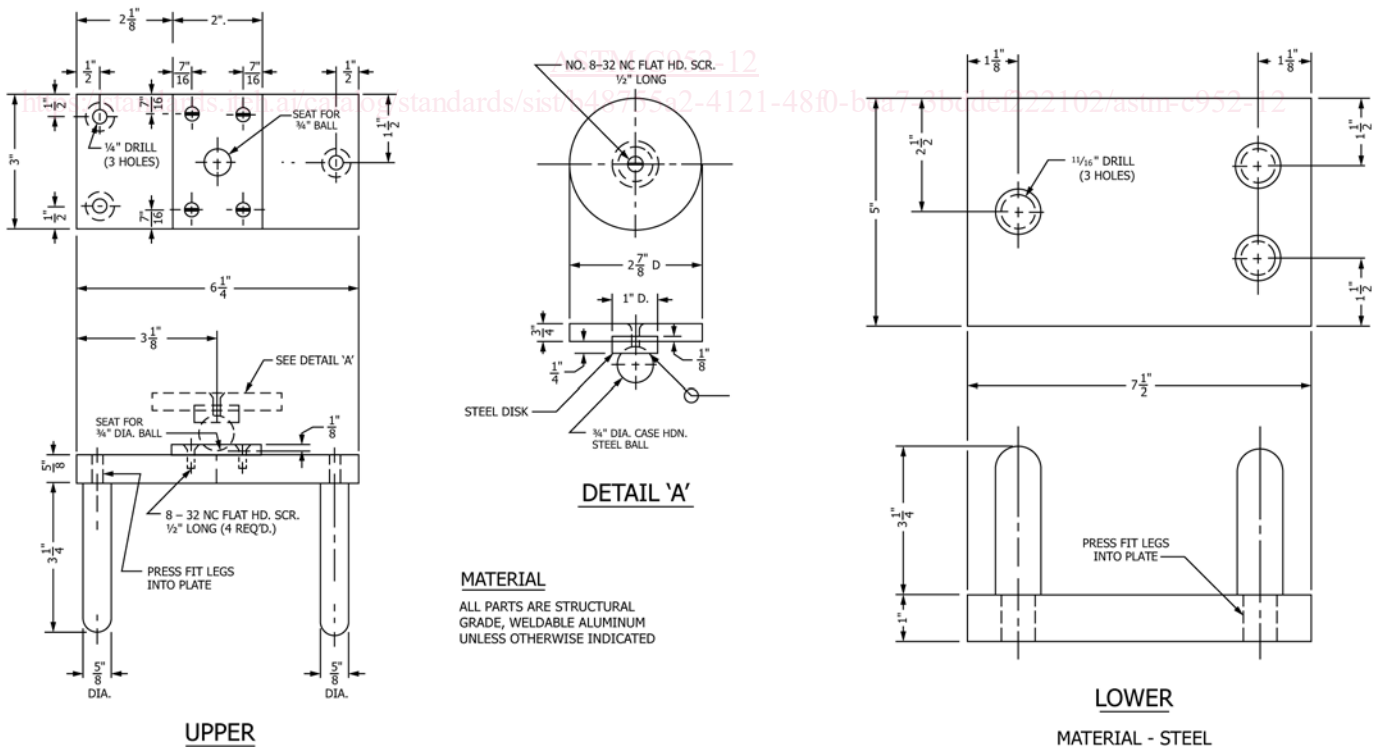

FIG. 4 Loading Jigs for Crossed-Brick Couplets