

ISO/FDIS 9098-1:2022(E)

ISO/TC 136

Secretariat: UNI

Date: ~~2022-12-19~~2023-01-18

~~Second edition~~

Bunk beds and high beds — Safety requirements and tests —

Part 1: Safety requirements

iTeh STANDARD PREVIEW
(standards.iteh.ai)

FDIS stage

Edited DIS - MUST BE USED FOR FINAL DRAFT

ISO/FDIS 9098-1:2022023(E)

© ISO 2022023

All rights reserved. Unless otherwise specified, or required in the context of its implementation, no part of this publication may be reproduced or utilized otherwise in any form or by any means, electronic or mechanical, including photocopying, or posting on the internet or an intranet, without prior written permission. Permission can be requested from either ISO at the address below or ISO's member body in the country of the requester.

ISO copyright office
CP 401 • Ch. de Blandonnet 8
CH-1214 Vernier, Geneva
Phone: + 41 22 749 01 11

Fax: + 41 22 749 09 47

E-mail: copyright@iso.org
Website: www.iso.org

Published in Switzerland

iTeh STANDARD PREVIEW
(standards.iteh.ai)

ISO/FDIS 9098-1

<https://standards.iteh.ai/catalog/standards/sist/9373eadc-5c2a-4168-bb08-a41f4565184b/iso-fdis-9098-1>

ii

iii

~~© ISO 2022 – All rights reserved~~

© ISO 2023 – All rights reserved

Edited DIS - MUST BE USED FOR FINAL DRAFT

Contents

Foreword	iv
1 Scope	1
2 Normative reference.....	1
3 Terms and definitions.....	1
4 Safety requirements.....	2
4.1 Construction.....	2
4.1.1 General.....	2
4.1.2 Accessible holes, gaps and openings.....	4
4.1.3 Bed base(s)	5
4.1.4 Safety barriers around upper beds.....	6
4.1.5 Means of access.....	8
4.1.6 Shear and squeeze points	12
4.1.7 All other accessible holes, gaps or openings.....	13
4.2 Strength of means of access: Attachment, deflection and strength	13
4.3 Durability of frame and fastenings	13
4.4 Stability (see A.5)	13
4.5 Fastening of the upper bed to the lower bed.....	13
5 Product information	14
5.1 Marking.....	14
5.2 Instructions for use	15
5.3 Purchase information.....	16
Annex A (informative) Rationale	17
Annex B (informative) Forces, cycles, loads, heights for stability, strength and durability tests of high beds and bunk beds.....	18

Foreword

ISO (the International Organization for Standardization) is a worldwide federation of national standards bodies (ISO member bodies). The work of preparing International Standards is normally carried out through ISO technical committees. Each member body interested in a subject for which a technical committee has been established has the right to be represented on that committee. International organizations, governmental and non-governmental, in liaison with ISO, also take part in the work. ISO collaborates closely with the International Electrotechnical Commission (IEC) on all matters of electrotechnical standardization.

The procedures used to develop this document and those intended for its further maintenance are described in the ISO/IEC Directives, Part 1. In particular the different approval criteria needed for the different types of ISO documents should be noted. This document was drafted in accordance with the editorial rules of the ISO/IEC Directives, Part 2 (see www.iso.org/directives).

Attention is drawn to the possibility that some of the elements of this document may be the subject of patent rights. ISO shall not be held responsible for identifying any or all such patent rights. Details of any patent rights identified during the development of the document will be in the Introduction and/or on the ISO list of patent declarations received (see www.iso.org/patents).

Any trade name used in this document is information given for the convenience of users and does not constitute an endorsement.

For an explanation on the voluntary nature of standards, the meaning of ISO specific terms and expressions related to conformity assessment, as well as information about ISO's adherence to the World Trade Organization (WTO) principles in the Technical Barriers to Trade (TBT) see the following URL: www.iso.org/iso/foreword.html.

This document was prepared by ISO/TC 136, *Furniture*.

This second edition cancels and replaces the first edition (ISO 9098-1:1994), which has been technically revised.

The main changes are as follows:

- Modification of the title;
- Specification of the scope;
- Terms and definitions of high bed, tread, completely bound opening, partially bound opening, upper bed, means of access, and handrail added;
- Requirements for the materials improved;
- Requirements for vertically protruding parts added;
- Requirements for accessible holes, gaps and openings added;
- Requirements for bed base(s) given in more detail;
- Requirements for safety barriers around beds added;
- Requirements for means of access added;
- Requirements for shear and squeeze points added;
- Requirements for platform and stairs added;

iv

iv

© ISO 2022 – All rights reserved

© ISO 2023 – All rights reserved

Edited DIS - MUST BE USED FOR FINAL DRAFT

ISO/FDIS 9098-1:20222023(E)

- Requirements for all other accessible holes, gaps or openings added;
- Requirements for strength of means of access: Attachment, deflection and strength added;
- Requirements for strength of frame and fastenings given in more detail;
- Requirements for the stability given in more detail;
- Requirements for the instructions for use given in more detail;
- Requirements for the marking given in more detail;
- Requirements for the purchase information added;
- Addition of informative [Annex A](#) and informative [Annex B](#).

A list of all parts in the ISO 9098 series can be found on the ISO website.

Any feedback or questions on this document should be directed to the user's national standards body. A complete listing of these bodies can be found at www.iso.org/members.html.

Field Code Changed

iTeh STANDARD PREVIEW
(standards.iteh.ai)

ISO/FDIS 9098-1

<https://standards.iteh.ai/catalog/standards/sist/9373eadc-5c2a-4168-bb08-a41f4565184b/iso-fdis-9098-1>

Bunk beds and high beds — Safety requirements and tests

Part 1: Safety requirements

1. Scope

This document specifies requirements for the safety, strength and durability of bunk beds and high beds for domestic and non-domestic use.

It applies to bunk beds and high beds with an internal length greater than 1 400 mm and a maximum bed base width of 1 200 mm, and with the upper surface of a bed base of 600 mm or more above the floor.

Requirements for other products incorporated in a bunk bed/high bed, for example a table or storage furniture, are not included in this document.

This document does not apply to bunk beds and high beds used for special purposes, including but not limited to prison, the military and fire brigades.

2. Normative reference

The following documents are referred to in the text in such a way that some or all of their content constitutes requirements of this document. For dated references, only the edition cited applies. For undated references, the latest edition of the referenced document (including any amendments) applies.

ISO 9098-2:—:—¹—Bunk beds and high beds — Safety requirements and tests — Part 2: Test methods

3. Terms and definitions

For the purposes of this document, the following terms and definitions apply.

ISO and IEC maintain terminology databases for use in standardization at the following addresses:

— ISO Online browsing platform: available at <https://www.iso.org/obp>

— IEC Electropedia: available at <https://www.electropedia.org/>

3.1

bunk bed

set of components that can be assembled as two beds, one above the other, where the upper surface of any bed base is 600 mm or more above floor

3.2

high bed

set of components that can be assembled as a bed, where the upper surface of the top bed base is 600 mm or more above the floor, irrespective of the use to which the space below is put

3.3

bed end structure

upright unit at the head and foot of the bed to which the *side rails* (3.6(3.6)) are attached

¹ Under preparation. Stage at the time of publication: ISO/FDIS 9098-2:2022.

ISO/FDIS 9098-1:2022/2023(E)

3.4

bed base

support structure for a mattress

3.5

safety barrier

component intended to prevent an occupant from falling out of the *upper bed* (3.10(3.10)) or the *high bed* (3.2(3.2))

3.6

side rail

longitudinal members attached to the *bed end structure* (3.3(3.3)) by which the *bed base* (3.4(3.4)) can be supported

3.7

tread

structure intended as a foothold

3.8

completely bound opening

opening that is continuously surrounded

3.9

partially bound opening

opening that is partially surrounded

3.10

upper bed

bed for which the upper surface of its bed base is 600 mm or more above the floor

3.11

means of access

ladder(s) or stairs to facilitate access to and egress from the upper bed or an access platform

3.12

handrail

rail or another component intended to assist the user to balance

4. Safety requirements

1. Construction

1. General

When the bed is fully assembled, accessible edges and corners shall be rounded or chamfered and free from burrs or sharp edges.

There shall be no open-ended tubes.

All assembly and pilot holes shall be made by the manufacturer.

There shall be no clothes hooks or similar items more than 600 mm from the floor.

If the lowest points of the vertically protruding parts are above 600 mm from the floor, they shall either:

1. a) — have an uninterrupted minimum horizontal dimension of 300 mm without any other vertical protrusion (see [Figure 1](#) [Figure 1](#) a), or

2

2

© ISO 2022 – All rights reserved

© ISO 2023 – All rights reserved

Edited DIS - MUST BE USED FOR FINAL DRAFT

ISO/FDIS 9098-1:2022/2023(E)

2. **b)** — have an uninterrupted vertical dimension of at least 600 mm measured from the highest adjacent part (see [Figure 1](#) **b**), or
3. **c)** — where the largest dimension is 50 mm or more (see [Figure 1](#) **c**), have a maximum height at which a line, drawn at 45° touches it, of not more than 5 mm above at least one adjacent/adjoining horizontal component; the maximum vertical protrusion above that component shall not exceed 20 % of the largest horizontal dimension of parts (see [Figure 1](#) **c**), or
4. **d)** — where the largest dimension is less than 50 mm, have a maximum height at which a line, drawn at 45° touches it, of not more than 5 mm above at least one adjacent/adjoining horizontal component; the maximum vertical protrusion above that component shall not exceed 10 mm (see [Figure 1](#) **d**) of parts (see [Figure 1](#) **d**).

It shall not be possible to dismantle the bed or its components without the use of a tool.

The dimensional requirements apply both before and after testing without re-tightening.

Dimensions in millimetres

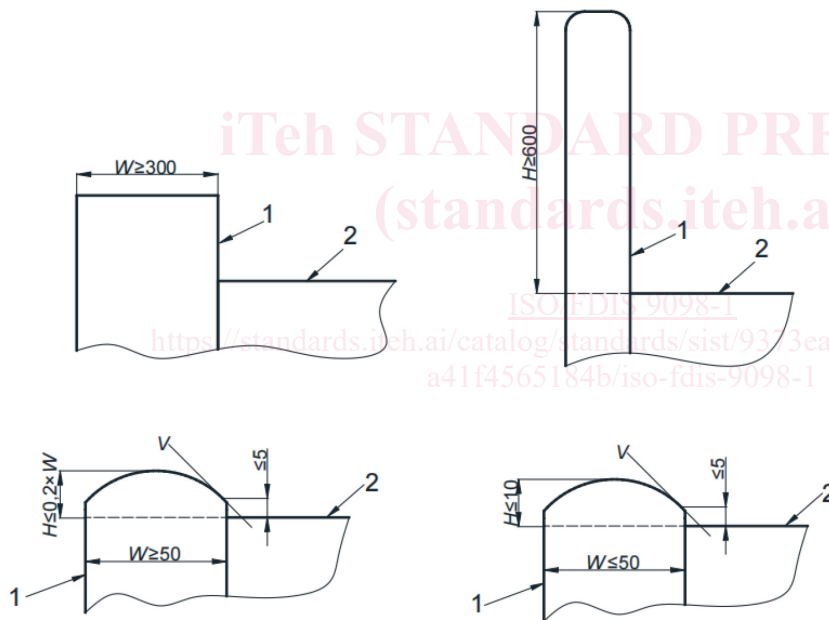

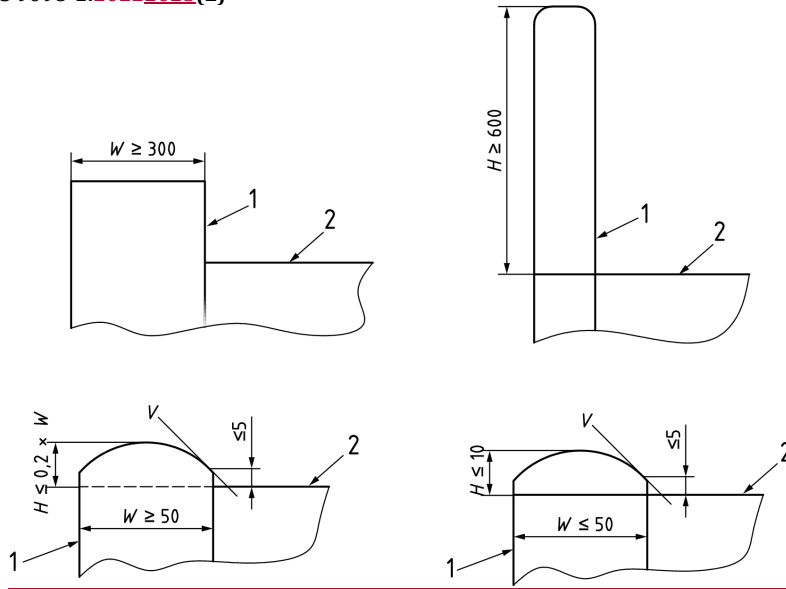

- Key**
- 1 vertically protruding part
 - 2 highest adjacent part
 - w width of protruding part
 - H height of protruding part
 - v 45° angle to the horizontal

iTeh STANDARD PREVIEW
(standards.iteh.ai)

Figure 1 — Examples of a vertically protruding part

1. Accessible holes, gaps and openings

1. General

Accessible completely bound openings in rigid material shall be with a diameter/width less than 7 mm or greater than 12 mm, unless the depth is less than 10 mm or unless the shape assessment probe enters when tested according to 6.3.1 of ISO 9098-2:202X:—.

Additionally, accessible completely bound openings in safety barriers, bed bases and treads, shall fulfil the requirements specified in the respective clauses, i.e. 4.1.3, 4.1.4 and 4.1.5.

2. Head entrapment on the outside of the bunk bed/high bed

The following requirements apply only to openings, where the lowest part is ≥ 600 mm from the floor.

Partially bound opening, V and irregular shaped openings shall be constructed so that:

1. a) — portion B of the template shall not enter the opening to the full thickness of the template according to 6.3.2 of ISO 9098-2:202X:—; or
2. b) — the apex of portion A of the template shall contact the base of the opening when tested according to 6.3.2 of ISO 9098-2:202X:—.

4

4

© ISO 2022 – All rights reserved

© ISO 2023 – All rights reserved

Edited DIS - MUST BE USED FOR FINAL DRAFT

1. Bed base(s)

1. Free space between bed bases in bunk beds

For bunk beds, the distance between the upper surface of the lower bed base and any part of the underside of the upper bed base shall be at least 750 mm.

2. Gaps and openings (see A.2.4.2)

Gaps adjacent to the inner surfaces of the side and end rails (see Figure 2) shall be less than 25 mm.

For beds where the bed base is an independent component, which is fitted between the side and end rails, the gap between the base and the side and end rails, shall be less than 25 mm when tested according to 6.3.1 of ISO 9098-2:2022.

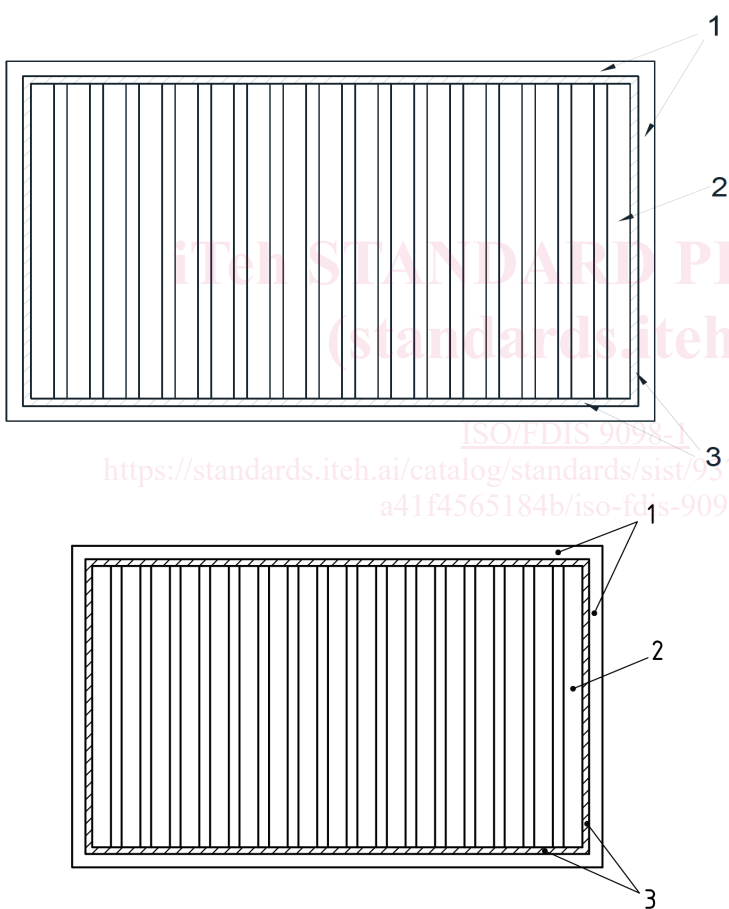

Key

- 1 bed frame (side and end rails)
- 2 bed base (slat)
- 3 gaps between bed base and bed frame