

~~ISO/FDIS 9098-2:2022(E)~~

ISO/TC 136

~~Date: 2022-12-19~~

Secretariat: UNI

~~Second edition~~

~~Date: 2023-01-18~~

Bunk beds and high beds — Safety requirements and tests —

Part 2: Test methods

iTeh STANDARD PREVIEW
(standards.iteh.ai)

ISO/FDIS 9098-2

<https://standards.iteh.ai/catalog/standards/sist/25d22aa2-7097-4b1e-81d0-7e/iso-fdis-9098-2>

FDIS stage

Edited DIS - MUST BE USED FOR FINAL DRAFT

ISO/FDIS 9098-2:20222023(E)

© ISO ~~2022~~2023

All rights reserved. Unless otherwise specified, or required in the context of its implementation, no part of this publication may be reproduced or utilized otherwise in any form or by any means, electronic or mechanical, including photocopying, or posting on the internet or an intranet, without prior written permission. Permission can be requested from either ISO at the address below or ISO's member body in the country of the requester.

ISO copyright office
CP 401 • Ch. de Blandonnet 8
CH-1214 Vernier, Geneva
Phone: + 41 22 749 01 11

Fax: + 41 22 749 09 47

E-mail: copyright@iso.org
Website: www.iso.org

Published in Switzerland

iTeh STANDARD PREVIEW
(standards.iteh.ai)

ISO/FDIS 9098-2

<https://standards.iteh.ai/catalog/standards/sist/23d22aa2-8f97-4b1e-81d0-4567d9171a7e/iso-fdis-9098-2>

ii

ii

© ISO 2022 – All rights reserved

© ISO 2023 – All rights reserved

Edited DIS - MUST BE USED FOR FINAL DRAFT

Contents

Foreword	v
1 Scope	1
2 Normative references.....	1
3 Terms and definitions.....	1
4 General test requirements	1
4.1 Preliminary preparation	1
4.2 Application of forces.....	2
4.3 Tolerances.....	2
5 Test apparatus.....	2
5.1 General	2
5.2 Test probes.....	2
5.2.1 Finger probes with hemispherical end	2
5.2.2 Shape assessment probe	3
5.2.3 Other probes	4
5.3 Bed base impactor	4
5.3.1 Circular body.....	6
5.3.2 Springs.....	6
5.3.3 Striking surface	6
5.4 Loading pads.....	6
5.5 Test mattress	8
5.5.1 General.....	8
5.5.2 Usage	8
5.6 Test mass.....	8
5.7 Stops.....	8
5.8 Floor surface	8
5.9 Tread impactor	8
5.10 Template for V-shaped openings.....	10
5.11 Foam.....	11
6 Test procedures.....	11
6.1 Inspection before testing.....	11
6.2 Inspection of product	11
6.3 Measurement.....	11
6.3.1 Holes, gaps and openings.....	11
6.3.2 V and irregular shaped holes, gaps and openings	12
6.4 Strength and durability tests.....	15
6.4.1 Positioning of the bed.....	15
6.4.2 Test of bed base and safety barrier	15
6.4.3 Test of the safety barriers around bed.....	18
6.4.4 Durability test of frame and fastenings.....	18

ISO/FDIS 9098-2:20222023(E)	
6.4.5 Test of means of access.....	20
6.4.6 Test of platforms, and platform barriers.....	23
6.5 Stability test.....	24
6.6 Fastening of the upper bed to the lower bed.....	24

iTeh STANDARD PREVIEW
(standards.iteh.ai)

ISO/FDIS 9098-2

<https://standards.iteh.ai/catalog/standards/sist/23d22aa2-8f97-4b1e-81d0-4567d9171a7e/iso-fdis-9098-2>

Foreword

ISO (the International Organization for Standardization) is a worldwide federation of national standards bodies (ISO member bodies). The work of preparing International Standards is normally carried out through ISO technical committees. Each member body interested in a subject for which a technical committee has been established has the right to be represented on that committee. International organizations, governmental and non-governmental, in liaison with ISO, also take part in the work. ISO collaborates closely with the International Electrotechnical Commission (IEC) on all matters of electrotechnical standardization.

The procedures used to develop this document and those intended for its further maintenance are described in the ISO/IEC Directives, Part 1. In particular the different approval criteria needed for the different types of ISO documents should be noted. This document was drafted in accordance with the editorial rules of the ISO/IEC Directives, Part 2 (see www.iso.org/directives).

Attention is drawn to the possibility that some of the elements of this document may be the subject of patent rights. ISO shall not be held responsible for identifying any or all such patent rights. Details of any patent rights identified during the development of the document will be in the Introduction and/or on the ISO list of patent declarations received (see www.iso.org/patents).

Any trade name used in this document is information given for the convenience of users and does not constitute an endorsement.

For an explanation on the voluntary nature of standards, the meaning of ISO specific terms and expressions related to conformity assessment, as well as information about ISO's adherence to the World Trade Organization (WTO) principles in the Technical Barriers to Trade (TBT) see the following URL: www.iso.org/iso/foreword.html.

This document was prepared by ISO/TC 136, *Furniture*.

This second edition cancels and replaces the first edition (ISO 9098-2:1994), which has been technically revised.

The main changes are as follows:

- ~~— —~~ **Modification of the title**;
- Expansion of **the** scope;
- ~~—~~ **General test requirements revised**;
- ~~—~~ Increase of apparatus;
- ~~Increase of and~~ test procedures;
- ~~Test~~ **Revision of general test requirements and test** report ~~revised~~.

A list of all parts in the ISO 9098 series can be found on the ISO website.

Any feedback or questions on this document should be directed to the user's national standards body. A complete listing of these bodies can be found at www.iso.org/members.html.

Formatted: Font

Field Code Changed

Bunk beds and high beds — Safety requirements and tests —

Part 2: Test methods

1 Scope

This document specifies test methods for the safety, strength and durability of bunk beds and high beds for domestic and non-domestic use.

The test applies to beds with an internal length greater than 1 400 mm and a maximum bed base width of 1 200 mm, and with the upper surface of a bed base 600 mm or more above the floor.

The tests are designed to be applied to a bed that is fully assembled and ready for use.

The applicable safety requirements are given in ISO 9098-1:~~202X~~:~~—~~.

2 Normative references

The following documents are referred to in the text in such a way that some or all of their content constitutes requirements of this document. For dated references, only the edition cited applies. For undated references, the latest edition of the referenced document (including any amendments) applies.

ISO 2439, *Flexible cellular polymeric materials — Determination of hardness (indentation technique)*

ISO 9098-1:~~—~~:~~—~~:~~—~~¹—*Bunk beds and high beds — Safety requirements and tests — Part 1: Safety requirements*

3 Terms and definitions

No terms and definitions are listed in this document. [ai/catalog/standards/sist/23d22aa2-8f97-4b1e-81d0-](https://www.iso.org/obp)

ISO and IEC maintain terminology databases for use in standardization at the following addresses:

- ISO Online browsing platform: available at <https://www.iso.org/obp>
- IEC Electropedia: available at <https://www.electropedia.org/>

4 General test requirements

4.1 Preliminary preparation

Unless otherwise specified by the manufacturer, the test item shall be stored in indoor ambient conditions for at least 24 h immediately prior to testing.

The sample shall be tested as delivered. Knock-down beds shall be assembled according to the manufacturer's instructions. If the instructions allow the bed to be assembled or combined in different ways, the most adverse combination shall be used for each test. Knock-down fittings shall be tightened before testing. Further tightening shall not take place unless specifically required by the manufacturer. If the configuration shall be changed to produce the worst-case conditions, this shall be recorded in the test report.

¹ Under preparation. Stage at the time of publication: ISO/FDIS 9098-1:2022.

ISO/FDIS 9098-2:2022/2023(E)

The test shall be carried out in indoor ambient conditions at a temperature between 15 °C and 27 °C. If, during a test, the temperature falls outside of the range of 15 °C to 27 °C, the maximum and/or minimum temperature shall be recorded in the test report.

The tests shall be carried out on the same sample and ~~following~~ follow the order of the clauses ~~of~~ in ISO 9098-1:202X.

If a test cannot be carried out as specified in this document, e.g. because a loading pad cannot be used for the application of a force due to the design of the product, the test can be carried out as closely as possible to the specified procedure. Any modification to the test method shall be technically justified and recorded in the test report.

4.2 Application of forces

The test forces in durability and static load tests shall be applied sufficiently slowly to ensure that negligible dynamic load is applied.

The forces in durability tests shall be applied sufficiently slowly to ensure that kinetic heating does not occur.

Unless otherwise specified, static loads shall be maintained for (10 ± 2) s. Unless otherwise specified, durability loads shall be applied for (2 ± 1) s.

The forces may be replaced by masses. The relationship of $10 \text{ N} = 1 \text{ kg}$ shall be used.

4.3 Tolerances

Unless otherwise stated, the following tolerances are applicable to the test equipment:

- ~~forces~~ forces shall have an accuracy of ± 5 % of the nominal force;
- ~~masses~~ masses shall have an accuracy of ± 1 % of the nominal mass;
- ~~dimensions less than 200 mm~~ dimensions less than 200 mm shall have an accuracy of ± 1 mm of the nominal dimension;
- ~~other dimensions~~ other dimensions shall have an accuracy of $\pm 0,5$ % of the nominal dimension; 2
- ~~angles~~ angles shall have an accuracy of $\pm 2^\circ$ of the nominal angle.

The tolerance for the positioning of loading pads shall be ± 5 mm.

NOTE For the purposes of uncertainty of measurement, test results are not considered to be adversely affected when the above tolerances are met.

5 Test apparatus

5.1 General

The test forces may, unless otherwise stated, be applied by any suitable device because results are dependent only upon correctly applied forces and loads, and not upon the apparatus.

The equipment shall be capable of following the deformation of the unit/component during testing so that the loads are always applied at specified points and in specified directions.

5.2 Test probes

5.2.1 Finger probes with hemispherical end

Probes with hemispherical ends made of plastic or other hard, smooth material, mounted on a force-measuring device, see ~~Figure 1~~ Figure 1.

2

2

© ISO 2022 – All rights reserved

© ISO 2023 – All rights reserved

Edited DIS - MUST BE USED FOR FINAL DRAFT

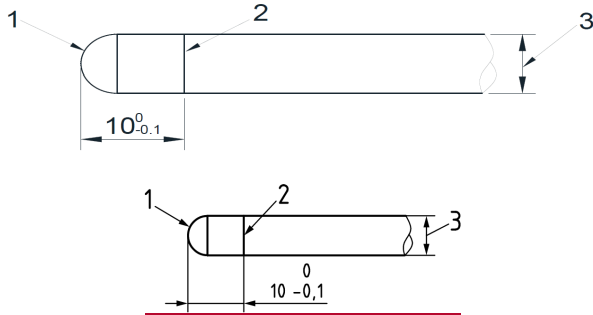

Key

- 1 hemispherical end
- 2 line around circumference
- 3 $\varnothing 7_{-0,1}^{+0}$ mm and $\varnothing 12_{0}^{+0,1}$ mm

Figure 1 — Finger probe with hemispherical end

5.2.2 Shape assessment probe

Probe made of plastics or other hard smooth materials with the dimensions shown in [Figure 2](#).
 Dimensions in millimetres

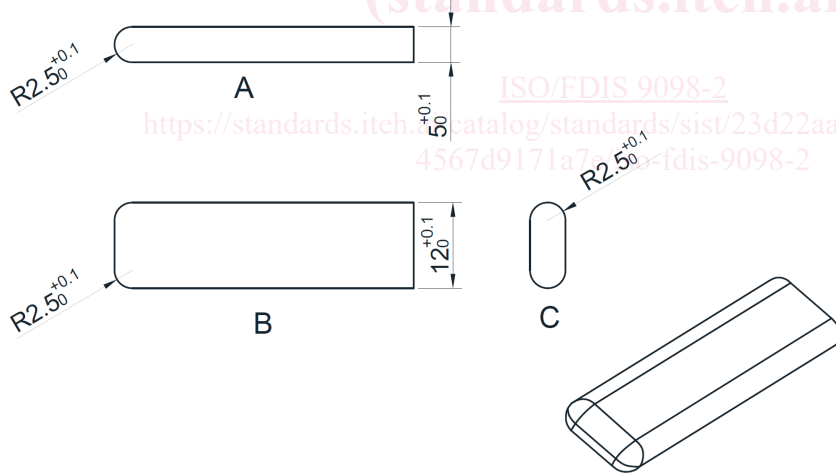

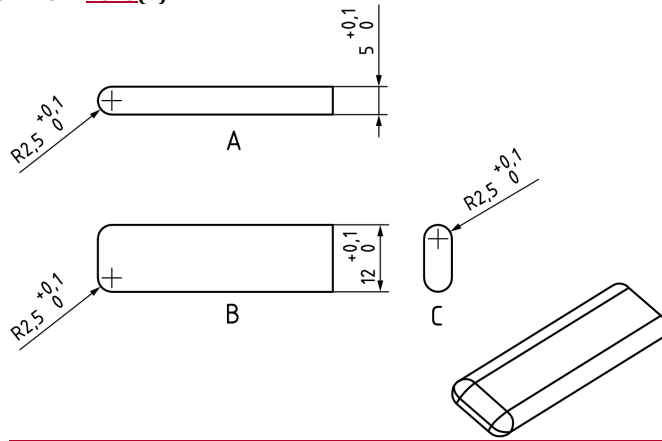

Key
 A side view
 B top view
 C end view

Figure 2 — Shape assessment probe

5.2.3 Other probes

Probes with the ends at an angle of $30^\circ \pm 0,5^\circ$ made of plastic or other hard, smooth material each with a diameter $(25_0^{+0,1})$ mm, $(60_0^{+0,1})$ mm and $(750_0^{-0,1})$ mm with rounded or conical ends, see Figure 3.

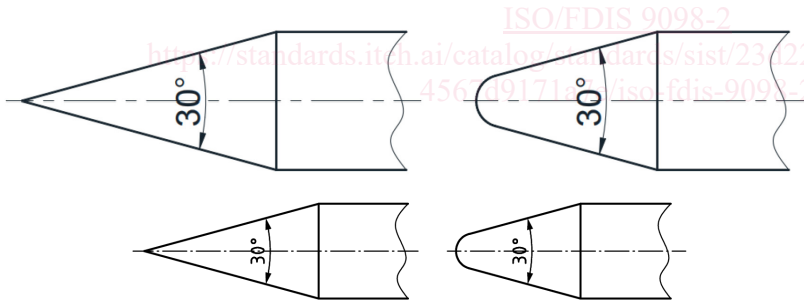

Figure 3 — Other probes

5.3 Bed base impactor

The bed base impactor shall be as shown in Figure 4 and comprised of the following:

4

4

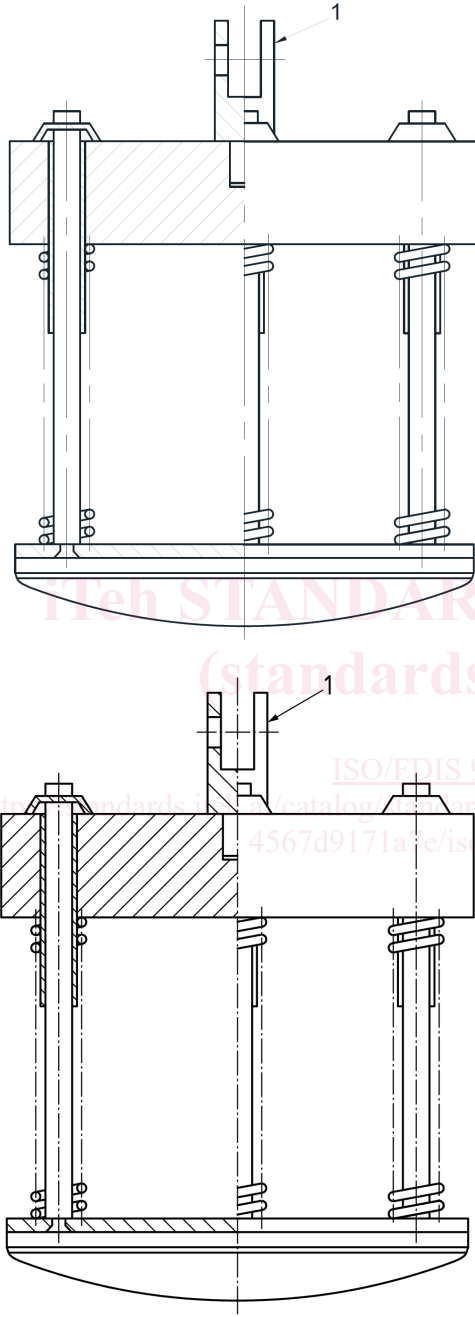

Key

1 joint of lifting device not inhibiting free fall

Figure 4 — Bed base impacter

5.3.1 Circular body

The circular body is 200 mm in diameter separated from the striking surface by helical compression springs and free to move relative to it on a line perpendicular to the plane of the central area of the striking surface.

The body and associated parts minus the springs shall have a mass of $(17 \pm 0,1)$ kg and the whole apparatus, including mass, springs and striking surface, shall have a mass of $(25 \pm 0,1)$ kg.

5.3.2 Springs

Springs shall be such that the nominal spring rate of the combined spring system is (7 ± 2) N/mm and the total friction resistance of the moving parts is less than 1 N.

The spring system shall be compressed to an initial load of $(1\ 040 \pm 5)$ N (measured statically), and the amount of spring compression movement available from the initial compression point to the point where the springs become fully closed shall be not less than 60 mm.

5.3.3 Striking surface

Rigid circular object, 200 mm in diameter, the face of which has a convex spherical curvature of a (300 ± 5) mm radius with a 12 mm front edge radius.

5.4 Loading pads

5.4.1 Loading pad, 200 mm in diameter, which is a rigid circular object, the loading surface of which has a convex spherical curvature of a (300 ± 5) mm radius with a 12 mm front edge radius (see [Figure 5](#)).

Dimensions in millimetres

ISO/FDIS 9098-2

<https://standards.iteh.ai/catalog/standards/sist/23d22aa2-8f97-4b1e-81d0-4567d9171a7e/iso-fdis-9098-2>