



Designation: C1741 – 12

Standard Test Method for Bleed Stability of Cementitious Post-Tensioning Tendon Grout¹

This standard is issued under the fixed designation C1741; the number immediately following the designation indicates the year of original adoption or, in the case of revision, the year of last revision. A number in parentheses indicates the year of last reapproval. A superscript epsilon (ϵ) indicates an editorial change since the last revision or reapproval.

1. Scope

1.1 This test method is designed to determine the bleed stability of freshly-mixed cementitious grout under static pressure.

1.2 *Units*—The values stated in SI units are to be regarded as standard. No other units of measurement are included in this standard.

1.3 *This standard does not purport to address all of the safety concerns, if any, associated with its use. It is the responsibility of the user of this standard to establish appropriate safety and health practices and determine the applicability of regulatory limitations prior to use.* (Warning—Fresh hydraulic cementitious mixtures are caustic and may cause chemical burns to skin and tissue upon prolonged exposure.²)

2. Referenced Documents

2.1 *ASTM Standards*:³

C125 Terminology Relating to Concrete and Concrete Aggregates

C938 Practice for Proportioning Grout Mixtures for Preplaced-Aggregate Concrete

3. Terminology

3.1 *Definitions*—For definitions of terms used in this test method, refer to Terminology C125.

3.2 *Definitions of Terms Specific to This Standard*:

3.2.1 *bleed stability, n*—of cementitious grout, resistance to bleeding.

3.2.2 *bleeding, n*—of cementitious post-tensioning tendon grout, autogenous flow of mixing water within, or its emergence from, newly placed grout; caused by the settlement of the solid materials within the grout and the filtering action of strands and wires when subjected to static pressure and capillary action.

3.2.3 *grout, n*—mixture of cementitious material and water, with or without aggregate and admixtures, proportioned to produce a pourable consistency without segregation of the constituents.

3.2.4 *post-tensioning, adj*—referring to a method of prestressing in which prestressing steel is tensioned after the concrete has gained sufficient strength.

4. Significance and Use

4.1 This test method is designed to evaluate the bleed stability of a freshly-mixed grout under static pressure. It can be used in both the laboratory to qualify grout materials and in the field as a quality control test. When used to qualify grout materials, replicate tests may be specified. It is intended that the test pressure, acceptance criteria, and number of replicate tests be set forth in the contract documents if this test method is referenced. These values will normally vary depending on the vertical rise of the post-tensioning tendon.

NOTE 1—Appendix X1 includes a reference for an example of test pressures and bleeding limits.

4.2 The procedure for this test was developed by Schokker et al.⁴ based on previous work by Schupack.⁵

5. Apparatus

5.1 The apparatus consists of a commercially available pressure filtration funnel, stand, pressure supply with gauge, pressure regulator, valve, drip wick, and bleed water collection container as shown in Fig. 1 and Fig. 2.

5.1.1 *Filtration Funnel*—A 47-mm diameter stainless steel pressure filtration funnel with a nominal capacity of 200 mL as shown in Fig. 2. The filtration funnel shall have removable threaded caps at both ends with a stem for connection of the

¹ This test method is under the jurisdiction of ASTM Committee C09 on Concrete and Concrete Aggregates and is the direct responsibility of Subcommittee C09.41 on Hydraulic Cement Grouts.

Current edition approved June 1, 2012. Published July 2012. Originally approved in 2011. Last previous edition approved in 2011 as C1741 – 11a. DOI: 10.1520/C1741-12.

² Section on Safety Precautions, *Manual of Aggregate and Concrete Testing, Annual Book of ASTM Standards*, Vol 04.02.

³ For referenced ASTM standards, visit the ASTM website, www.astm.org, or contact ASTM Customer Service at service@astm.org. For *Annual Book of ASTM Standards* volume information, refer to the standard's Document Summary page on the ASTM website.

⁴ Schokker, A. J., Koester, B. D., Breen, J. E., and Kreger, M. E., "Development of High Performance Grouts for Bonded Post-Tensioned Structures," Research Report 1405-2, Center for Transportation Research, October 1999.

⁵ Schupack, M. "Admixture for Controlling Bleed in Cement Grout Used in Post-Tensioning," *Precast/Prestressed Concrete Institute Journal*, Nov.–Dec. 1974, pp. 1–10.



FIG. 1 Test Apparatus

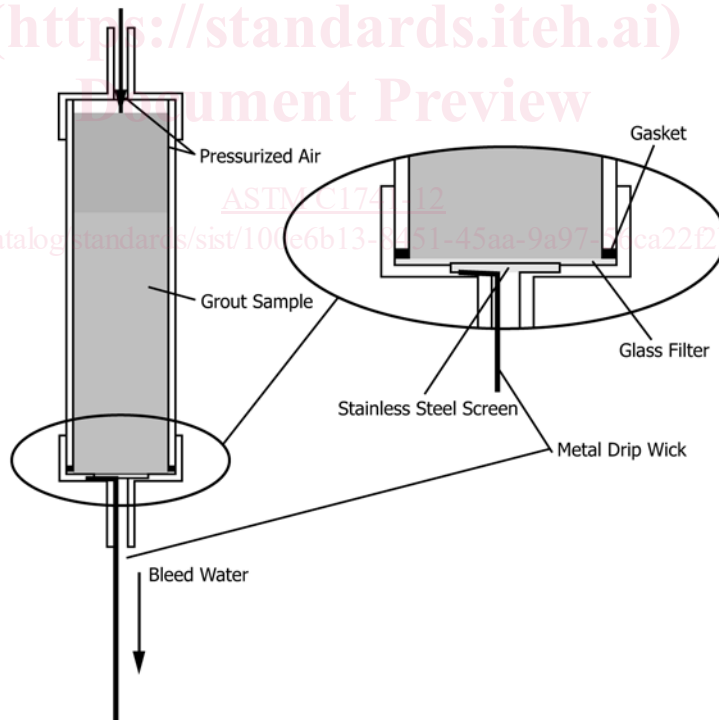

FIG. 2 47-mm Filtration Funnel with 200 mL Nominal Capacity

gas supply and a 7.0 ± 0.5 mm inside diameter stem 90 ± 1 mm long for escape of water. The base of the vessel shall contain a 35 ± 1 mm diameter stainless steel $45 \mu\text{m}$ (No. 325) screen that supports a 47 mm diameter Type A/E borosilicate

glass filter ($1\text{-}\mu\text{m}$ pore size) as shown in Fig. 2. The screen shall be inserted with the woven side against the glass filter, and the funnel gasket shall be placed above the glass filter as shown in Fig. 2. The glass filter shall cover the screen across the inside