



Designation: **D6737 – 01 (Reapproved 2006) D6737 – 12**

## Standard Test Method for Bulk Density of Tapered Paintbrush Filaments<sup>1</sup>

This standard is issued under the fixed designation D6737; the number immediately following the designation indicates the year of original adoption or, in the case of revision, the year of last revision. A number in parentheses indicates the year of last reapproval. A superscript epsilon ( $\epsilon$ ) indicates an editorial change since the last revision or reapproval.

### 1. Scope

- 1.1 This test method covers a procedure for measuring the weight of filaments per unit volume.
- 1.2 This method is applicable only to monofilament with tapered longitudinal profiles.
- 1.3 The values given in SI units are to be regarded as the standard. The values given in parentheses ~~allow for calculating the bulk density in g/in. are for information only.~~<sup>3</sup> ~~a commonly used form.~~
- 1.4 *This standard does not purport to address all of the safety concerns, if any, associated with its use. It is the responsibility of the user of this standard to establish appropriate safety and health practices and determine the applicability of regulatory limitations prior to use.*

### 2. Summary of Test Method

- 2.1 The weight, length and diameter of a bundle of tapered filaments are measured, and the bundle density is calculated.

### 3. Significance and Use

- 3.1 Filaments are available in a variety of cross-sections and materials. A measure of bulk density permits the brushmaker to estimate the weight of filament required to prepare a given number of brushes.

### 4. Apparatus

- 4.1 The apparatus requires some machining, and is assembled as shown in Fig. 1 from the following equipment:
  - 4.1.1 *Air Valve.*<sup>2</sup>
  - 4.1.2 *Miniature Air Cylinder*, dual acting, heavy duty.<sup>3</sup>
  - 4.1.3 Assorted parts shown in Fig. 1 are machined from 304 stainless steel and assembled as shown along with the air valve and cylinder just described. The Pi tape<sup>4</sup> must be fixed in place so that it reads accurately the diameter of a metal calibration standard that is 50.8-mm (2.00-in.) diameter. The Pi tape is mounted on an adjustable plate for calibration.
- 4.2 *Weighing Device*, accurate to 0.1 g to weigh the bundle.
- 4.3 *Graduated, Linear Scale*, accurate to 0.5-mm (0.02-in.) to measure the bundle length.
- 4.4 *Air Supply*, with pressure regulator set for 40 psig.
- 4.5 *Calibration Standard*, 50.8-mm (2.00-in.) in diameter.<sup>5</sup>

### 5. Sampling, Test Specimens and Test Units

- 5.1 The test result depends on the cross-sectional shape, the polymer, and the length of the bundle selected for the test. To a lesser extent, it also depends on the filament diameter, since thin filaments pack more efficiently than large ones.
- 5.2 The device, as pictured in Fig. 1, is designed to measure diameters ranging from 30.5 to 52.3 mm (1.20 to 2.06 in.). Make sure that both ends to be measured are within this range.

<sup>1</sup> This test method is under the jurisdiction of ASTM Committee D01 on Paint and Related Coatings, Materials, and Applications and is the direct responsibility of Subcommittee D01.61 on Paint Application Tools.

Current edition approved Nov. 1, 2006 June 1, 2012. Published November 2006 July 2012. Originally approved in 2001. Last previous edition approved in 2004 2006 as D6737 – 01-D6737 – 01 (2006). DOI: 10.1520/D6737-01R06.10.1520/D6737-12.

<sup>2</sup> Air valve such as Model 6676 available from Hunt Valve Co., 1913 E. State Street, Salem, Ohio 44460, or equivalent, has been found suitable for this purpose.

<sup>3</sup> Miniature air cylinder such as Model 047 DXP, 3/4 in. (19.0 mm) bore 7 in. (178 mm) stroke, dual acting, heavy duty available from Bimba Manufacturing Company, Monee, IL 60449-0068, or equivalent, has been found suitable for this purpose.

<sup>4</sup> Pi tape 1/4 in. (6 mm)  $\times$  6 ft (1.8 m) with 0.01 in. graduations. Lufkin model W606P, or equivalent, has been found suitable for this purpose.

<sup>5</sup> Steel cylinder machined to diameter of 2.000 by tolerance (0.001 by 0.001) in. (50.8 by tolerance (0.02 by 0.02) mm).

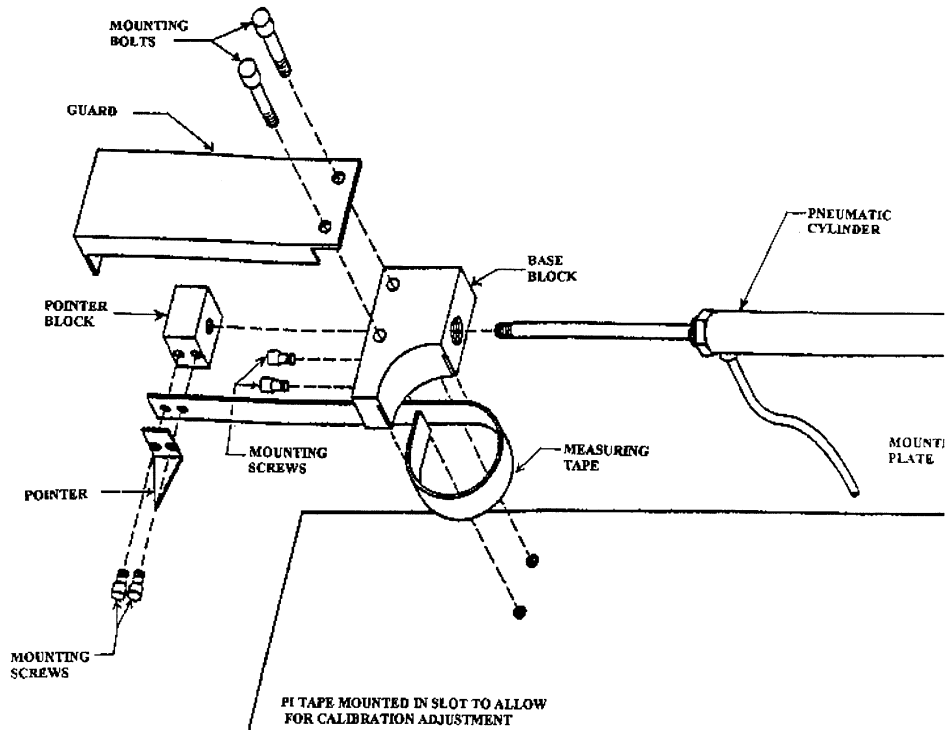

FIG. 1 Apparatus to Measure Bundle Diameter

5.3 Calculations are based on (conical bundle shape.

6. Procedure

6.1 Select a sample bundle of approximately 50-mm (2.0-in.) diameter. Filament may be removed from a sample so the bundle diameter falls within the scale range 30.5 to 52.3-mm (1.20 to 2.06-in.). One convenient method to adjust the sample diameter to the desired range is to fill a 50-mm (2.0-in.) inside diameter tube. If the sample is too small, like samples may be combined to adjust the bundle diameter to the desired range.

6.2 With rubber bands holding the bundle together, roll it between the palms of the hands four times to allow the filaments to nest. Place the larger end of the bundle inside the loop of measuring tape in the device shown in Fig. 2.

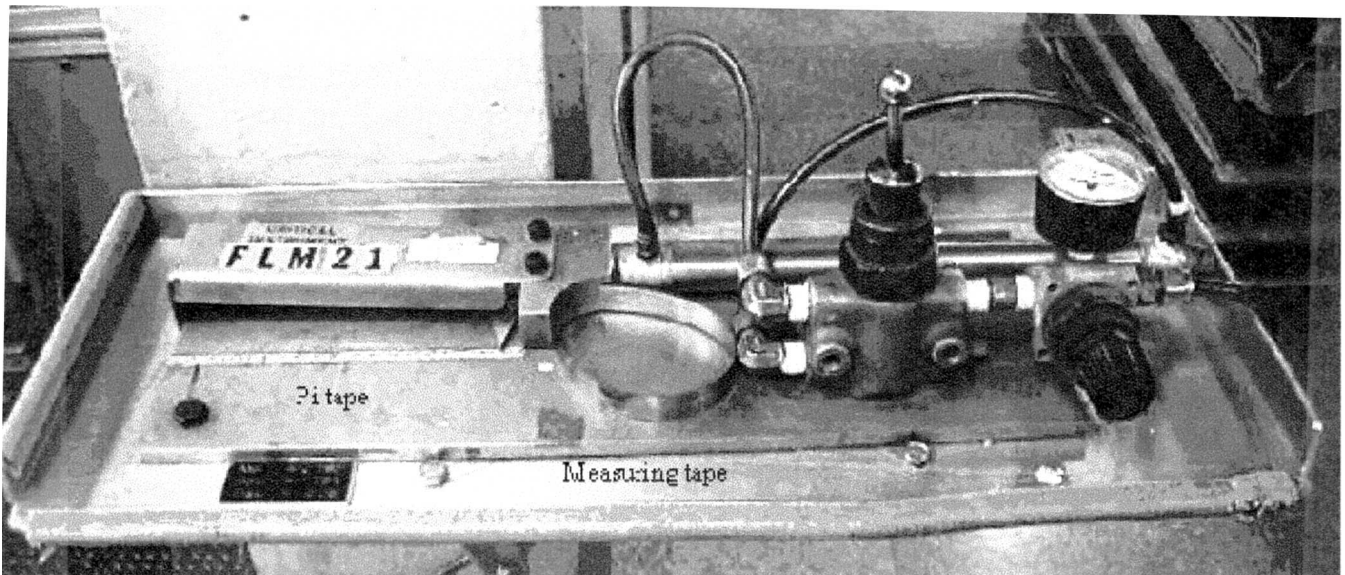

FIG. 2 Assembled Bundle Diameter Apparatus