



Designation: E1135 – 12

Standard Test Method for Comparing the Brightness of Fluorescent Penetrants¹

This standard is issued under the fixed designation E1135; the number immediately following the designation indicates the year of original adoption or, in the case of revision, the year of last revision. A number in parentheses indicates the year of last reappraisal. A superscript epsilon (ϵ) indicates an editorial change since the last revision or reappraisal.

1. Scope*

1.1 This test method describes the techniques for comparing the brightness of the penetrants used in the fluorescent dye penetrant process. This comparison is performed under controlled conditions which eliminate most of the variables present in actual penetrant examination. Thus, the brightness factor is isolated and is measured independently of the other factors which affect the performance of a penetrant system.

1.2 The brightness of a penetrant indication is dependent on the developer with which it is used. This test method however, measures the brightness of a penetrant on a convenient filter paper substrate which serves as a substitute for the developer.

1.3 The brightness measurement obtained is color-corrected to approximate the color response of the average human eye. Since most examination is done by human eyes, this number has more practical value than a measurement in units of energy emitted. Also, the comparisons are expressed as a percentage of some chosen standard penetrant because no absolute system of measurement exists at this time.

1.4 *This standard does not purport to address all of the safety concerns, if any, associated with its use. It is the responsibility of the user of this standard to establish appropriate safety and health practices and determine the applicability of regulatory limitations prior to use.*

2. Referenced Documents

2.1 *ASTM Standards:*²

[E691 Practice for Conducting an Interlaboratory Study to Determine the Precision of a Test Method](#)

[E1316 Terminology for Nondestructive Examinations](#)

3. Terminology

3.1 *Definitions:*

¹ This test method is under the jurisdiction of ASTM Committee E07 on Nondestructive Testing and is the direct responsibility of Subcommittee E07.03 on Liquid Penetrant and Magnetic Particle Methods.

Current edition approved June 15, 2012. Published July 2012. Originally approved in 1986. Last previous edition approved in 2008 as E1135 – 97 (2008) ^{ϵ 1}. DOI: 10.1520/E1135-12.

² For referenced ASTM standards, visit the ASTM website, www.astm.org, or contact ASTM Customer Service at service@astm.org. For *Annual Book of ASTM Standards* volume information, refer to the standard's Document Summary page on the ASTM website.

3.1.1 Definitions of terms applicable to this test method may be found in Terminology [E1316](#).

4. Summary of Test Method

4.1 Simulated indications are prepared by impregnating filter paper with a specified quantity of the penetrant under test. The samples and similarly prepared standards are then measured in a fluorometer equipped to excite the penetrant with near ultraviolet (black) light and respond to color approximately as does the human eye under the conditions encountered during a normal examination. The fluorometer must be equipped with a special sample holder to accept the samples employed.

4.2 The sample preparation is not indicative of the total system performance but is convenient as a lot acceptance test. A known amount of penetrant is diluted with a specified amount of a volatile solvent, pieces of filter paper are soaked in the mixture, the paper is dried under specified conditions at room temperature, placed in the sample holder, and measured with the fluorometer.

5. Significance and Use

5.1 The penetrant is one of the major components of the fluorescent penetrant process, and very influential in the degree of performance attained by a given system or group of materials. The penetrant must enter the discontinuity, be removed from the part surface but not from the discontinuity, be brought out of the discontinuity by the developer, and finally viewed and detected by the inspector. If all processing parameters are optimized for the parts being examined and the examination materials in use, the intrinsic brightness of the penetrant becomes the factor which governs the sensitivity of the system.

5.2 Because the eye responds logarithmically rather than linearly to changes of brightness, differences in brightness must be fairly large to be significant. Differences of 25 % are obvious, 12 % noticeable, and 6 % detectable by the eye. Experts may sometimes detect 3 % differences, but these are not usually significant to the average observer.

5.3 The significance of the results also depends on the deviation between readings on the same material sample. Different samples, even when prepared out of the same initial quantity of penetrant will not exactly reproduce readings.

*A Summary of Changes section appears at the end of this standard



FIG. 1 Turner Fluorometer, with Door Open Showing Sample Holder and Filters in Place

These differences occur because of paper differences and penetrant migration on the paper samples.

5.4 To determine the confidence limits for the test results, it is necessary to perform certain statistical calculations. The confidence limits are determined by the equation:

$$CL = \bar{X} \pm ts/\sqrt{n} \quad (1)$$

where:

CL = the limits within which we can be confident the value lies,

\bar{X} = the average of all readings,

t = "student's t" (values of which are given by statistical manuals),

n = the number of readings used,

s = the standard deviation determined by the equation:

$$s = \sqrt{\frac{\sum (X - \bar{X})^2}{n - 1}} \quad (2)$$

where:

X = the individual readings.

In this use, the 95 % confidence level (the value will lie within the limits 95 % of the time) is sufficient. At this level, t for 4 samples is 3.182.

5.4.1 If the confidence limits of two material samples overlap, the materials must be considered equal even though the measured average values are different.

6. Apparatus

6.1 *Filter Paper*, a good quality Chromatography paper such as Whatman #3 mm Chromatography paper or Whatman #4.

6.2 *Pipets*, 1-mL capacity.

6.3 *Volumetric Flasks*, with stopper, 25-mL.

6.4 *Paper Drying Holders*—"Crocodile" type battery clips 2 in. long with ½ in. opening have been found satisfactory. Set up holders to allow drying inside desiccator.

6.5 *Methylene Chloride or Acetone*, technical grade.

6.6 *Desiccator*, 250-mm diameter or larger.

6.7 *Silica Gel*, for use as desiccant.

7. Sample Preparation

7.1 *Sample Preparation*—Normally a set of samples of a standard material must be prepared along with any test samples.

7.1.1 Pipet 1.0 mL of chosen penetrant into a 25-mL stoppered volumetric flask.

7.1.2 Fill flask to line with methylene chloride or acetone, stopper and mix. (If penetrant is not soluble in methylene chloride, use acetone.)

7.1.3 Pour 10 to 20 mL of mixture into a 50-mL beaker.

7.1.4 Using forceps, dip 4 papers (cut to size for sample holder in use), one at a time, into beaker, withdraw by drawing across the lip of the beaker to remove excess liquid, and clip into paper drying holder. Holder shall cover as small an area of paper as possible.

7.1.5 Hang papers in a vertical position inside desiccator until dry. This will require approximately 5 min at room temperature.

8. Procedure for Turner Fluorometer

NOTE 1—This instrument is no longer in production and can not be purchased from Turner.

NOTE 2—All available apparatus may not be suitable for these applications.

8.1 *Sample Holder*, designed for the fluorometer in use.

8.1.1 The sample holder for the Turner Fluorometers (see Fig. 1) is detailed in Fig. 2. It is designed for use in the standard

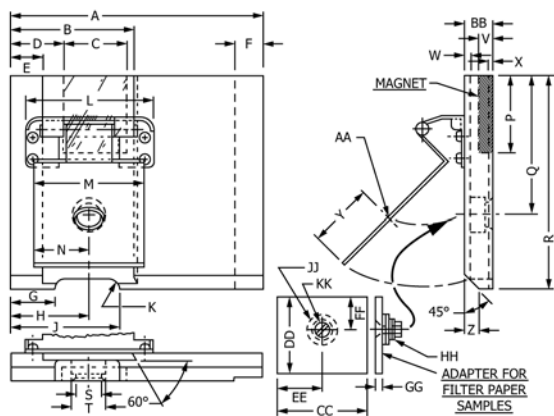

Dimensions

	in.	mm
A	4.5	114.3
B	2.186	55.52
C	1.125	28.575
D	0.875	22.225
E	0.563	14.30
F	0.50	12.70
G	0.813	20.65
H	1.375	34.925
J	1.938	49.225
K	0.188 radius (2)	4.775
L	2.25	57.15
M	2.00	50.80
N	1.00	25.40
P	1.375	34.925
Q	2.50	63.50
R	3.813	96.85
S	0.438 diameter drill thru	11.125
T	0.625 diameter counterbore 0.25 deep	15.875
V	0.25	6.35
W	0.125	3.175
X	0.063	1.60
Y	1.125	28.575
Z	0.25	6.35
AA	0.50 drill thru & chamfer	12.70
BB	0.50	12.70
CC	1.594	40.489
DD	1.375	34.925
EE	0.797	20.244
FF	0.625	15.875
GG	0.125	3.175
HH	(2) No. 6 flat washers	
JJ	(2) 3/16 in. (4.76 mm) flat washers	
KK	(1) No. 6 (0.138) flat head machine screw 1/2 in. (12.7 mm) long & hex nut	

FIG. 2 Sample Holder for the Turner Fluorometer

door from which the spring clip and the interior portion of the tube holder have been removed.

8.2 *Primary Light Filter*—The primary (light source) filter for the Turner fluorometers is a Corning-Kopp CS 7-37 2-in. square^{3,4} glass filter.

³ If you are aware of alternative suppliers, please provide this information to ASTM Headquarters. Your comments will receive careful consideration at a meeting of the responsible technical committee,¹ which you may attend.

⁴ The sole source of supply known to the committee at this time is Kopp Glass Inc., P.O. Box 8255, Pittsburgh, PA 15218.

8.3 *Secondary Light Filters*—The secondary (detector) filter system consists of a Corning-Kopp 3-77 and Kodak #2A, 86A and CC40Y.^{3,5} The Turner fluorometer requires 2 in. square filters.

8.4 *Neutral Density Intensity Reducing Filters*—An assortment of photographic type filters is required. These should be the same size as the secondary filters (8.3) and the filters chosen for any measurement should be mounted with the secondary filters.

8.5 Place the primary filter in the right filter holder and the secondary filters in the left filter holder.

8.6 Insert neutral density filters in secondary filter position and set sensitivity control (under primary filter) to “1”.

8.7 Turn on instrument and allow 15 min warm up before use.

8.8 Place a prepared sample of the brightest material to be measured in the sample holder.

8.9 Place holder in instrument door, close door, and note reading. Open door and insert proper neutral density filters to bring reading on scale, preferably in the 70 to 90 scale division range.

8.10 Open door, remove sample holder, remove sample, and replace with an untreated filter paper.

8.11 Place sample holder in door, close door, and set reading to zero with “blank” control.

8.12 Remove blank paper and insert prepared samples for measurement. Alternate samples of unknown and standard material to minimize affect of any instrument drift which might occur.

9. Procedure for Coleman Fluorometer

NOTE 3—This instrument is no longer in production and can not be purchased from Coleman.

9.1 *Sample Holder*—The sample holder for the Coleman Fluorometer (see Fig. 3) is detailed in Fig. 4. It is designed for insertion into the sample port in the top of the instrument. Stops to control its rotation may be installed on the instrument case and the sample holder.

9.2 *Primary Light Filter*—The primary (light source) filter for the Coleman 12C is the Coleman B-1 or B-1-S filter.

9.3 *Secondary Light Filter*—The secondary (Detector) filter system consists of a Corning-Kopp 3-77 and Kodak #2A, 86A, and CC40Y. The filter size 1 5/8 in. by 1 5/8 in. These must be mounted in an empty filter frame to be inserted in the fluorometer.

9.4 *Neutral Density Intensity Reducing Filters*—An assortment of photographic type filters are required and should be mounted with the secondary filters.

9.5 Insert a Coleman B-1 or B-1-S filter (in Coleman filter frame) into primary filter position (horizontal position behind sensitivity control lever) and a package of filters consisting of

⁵ The sole source of supply of the Kodak 2A, 86A, and CC40Y known to the committee at this time is Eastman Kodak, Inc., Rochester, NY 14650.