**Tools for pressing — Gas springs —
Part 4:
Gas springs with increased spring
force and same built height**

Outillage de presse — Ressorts à gaz —

*Partie 4: Ressorts à gaz à force accrue à même encombrement en
hauteur*

<https://standards.iteh.ai>
Document Preview

[ISO 11901-4:2021](https://standards.iteh.ai/catalog/standards/iso/f0b67f8f-0c73-4cb0-ac2c-fafe5fa7fd7e/iso-11901-4-2021)

<https://standards.iteh.ai/catalog/standards/iso/f0b67f8f-0c73-4cb0-ac2c-fafe5fa7fd7e/iso-11901-4-2021>



iTeh Standards
(<https://standards.iteh.ai>)
Document Preview

[ISO 11901-4:2021](https://standards.iteh.ai/catalog/standards/iso/f0b67f8f-0c73-4cb0-ac2c-fafe5fa7fd7e/iso-11901-4-2021)

<https://standards.iteh.ai/catalog/standards/iso/f0b67f8f-0c73-4cb0-ac2c-fafe5fa7fd7e/iso-11901-4-2021>



COPYRIGHT PROTECTED DOCUMENT

© ISO 2021

All rights reserved. Unless otherwise specified, or required in the context of its implementation, no part of this publication may be reproduced or utilized otherwise in any form or by any means, electronic or mechanical, including photocopying, or posting on the internet or an intranet, without prior written permission. Permission can be requested from either ISO at the address below or ISO's member body in the country of the requester.

ISO copyright office
CP 401 • Ch. de Blandonnet 8
CH-1214 Vernier, Geneva
Phone: +41 22 749 01 11
Email: copyright@iso.org
Website: www.iso.org

Published in Switzerland

Contents

	Page
Foreword	iv
1 Scope	1
2 Normative references	1
3 Terms and definitions	1
4 Description and terminology	1
5 Interchangeability dimensions and characteristics	2
5.1 General nominal specifications	2
5.2 Gas springs of type 7 500 to 15 000	3
5.3 Gas springs of type 24 000 to 200 000	3
6 Marking	7
7 Technical delivery conditions	8
8 Designation	8
Bibliography	9

iTeh Standards
(<https://standards.iteh.ai>)
Document Preview

[ISO 11901-4:2021](https://standards.iteh.ai/catalog/standards/iso/f0b67f8f-0c73-4cb0-ac2c-fafe5fa7fd7e/iso-11901-4-2021)

<https://standards.iteh.ai/catalog/standards/iso/f0b67f8f-0c73-4cb0-ac2c-fafe5fa7fd7e/iso-11901-4-2021>

Foreword

ISO (the International Organization for Standardization) is a worldwide federation of national standards bodies (ISO member bodies). The work of preparing International Standards is normally carried out through ISO technical committees. Each member body interested in a subject for which a technical committee has been established has the right to be represented on that committee. International organizations, governmental and non-governmental, in liaison with ISO, also take part in the work. ISO collaborates closely with the International Electrotechnical Commission (IEC) on all matters of electrotechnical standardization.

The procedures used to develop this document and those intended for its further maintenance are described in the ISO/IEC Directives, Part 1. In particular, the different approval criteria needed for the different types of ISO documents should be noted. This document was drafted in accordance with the editorial rules of the ISO/IEC Directives, Part 2 (see www.iso.org/directives).

Attention is drawn to the possibility that some of the elements of this document may be the subject of patent rights. ISO shall not be held responsible for identifying any or all such patent rights. Details of any patent rights identified during the development of the document will be in the Introduction and/or on the ISO list of patent declarations received (see www.iso.org/patents).

Any trade name used in this document is information given for the convenience of users and does not constitute an endorsement.

For an explanation of the voluntary nature of standards, the meaning of ISO specific terms and expressions related to conformity assessment, as well as information about ISO's adherence to the World Trade Organization (WTO) principles in the Technical Barriers to Trade (TBT), see www.iso.org/iso/foreword.html.

This document was prepared by Technical Committee ISO/TC 29, *Small tools*, Subcommittee SC 8, *Tools for pressing and moulding*.

This second edition cancels and replaces the first edition (ISO 11901-4:2014), which has been technically revised.

The main changes compared to the previous edition are as follows:

- addition of gas spring type 7 500, 15 000 and 200 000;
- modification of the nominal initial force of gas springs type 10 000, from 10 000 to 9 200;
- modification of the end of stroke nominal force increase coefficient to have a range from 1,5 to 1,8 for all gas springs;
- replacement of length l_6 with diameter D_3 in [Table 2](#) and in [Figure 2](#) et [Figure 3](#);
- modification of the symbol of nominal stroke.

A list of all parts in the ISO 11901 series can be found on the ISO website.

Any feedback or questions on this document should be directed to the user's national standards body. A complete listing of these bodies can be found at www.iso.org/members.html.

Tools for pressing — Gas springs —

Part 4: Gas springs with increased spring force and same built height

1 Scope

This document specifies the dimensions (in millimetres), nominal initial forces and types of gas springs.

It is applicable to gas springs with increased spring force and same built height of type 7 500 to 200 000, pressurized with nitrogen with a nominal initial force of between 7 400 N (with a tolerance of $\pm 5\%$) and 200 000 N (with a tolerance of $\pm 5\%$), for use in press tools.

It also specifies marking, technical delivery conditions and designation.

NOTE Specifications of mounting accessories for gas springs are given in ISO 11901-2.

2 Normative references

The following documents are referred to in the text in such a way that some or all of their content constitutes requirements of this document. For dated references, only the edition cited applies. For undated references, the latest edition of the referenced document (including any amendments) applies.

ISO 7-1, *Pipe threads where pressure-tight joints are made on the threads — Part 1: Dimensions, tolerances and designation*

ISO 2768-1, *General tolerances — Part 1: Tolerances for linear and angular dimensions without individual tolerance indications*

3 Terms and definitions

No terms and definitions are listed in this document.

ISO and IEC maintain terminology databases for use in standardization at the following addresses:

- ISO Online browsing platform: available at <https://www.iso.org/obp>
- IEC Electropedia: available at <http://www.electropedia.org/>

4 Description and terminology

See [Figure 1](#).

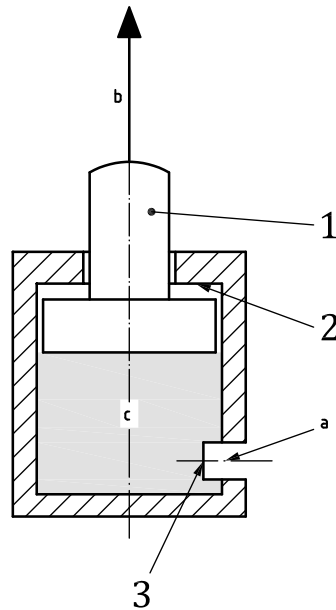

Key

- 1 rod
- 2 positive stop
- 3 valve
- a Pressure filling inlet.
- b Force.
- c Nitrogen.

iTeh Standards
 (https://standards.itih.ai)
 Document Preview

Figure 1 — Terminology

The gas spring is an autonomous spring pressurized with nitrogen.

At rest position, the rod is pushed out.

This gas spring feature has a gas inlet for pressurization or depressurization. The inlet is located on the casing and is capped.

The pressure filling inlet of the gas springs shall include a pipe thread ISO 7 - Rp 1/8 in accordance with ISO 7-1.

5 Interchangeability dimensions and characteristics

5.1 General nominal specifications

See [Table 1](#).