

FINAL
DRAFT

INTERNATIONAL
STANDARD

ISO/FDIS
10297

ISO/TC 58/SC 2

Secretariat: AFNOR

Voting begins on:
2023-12-19

Voting terminates on:
2024-02-13

Gas cylinders — Cylinder valves — Specification and type testing

*Bouteilles à gaz — Robinets de bouteilles — Spécifications et essais de
type*

iTeh Standards
(<https://standards.iteh.ai>)
Document Preview

[ISO/FDIS 10297](#)

<https://standards.iteh.ai/catalog/standards/sist/63f2ec4a-76ca-4df9-947d-56cbbd2d2729/iso-fdis-10297>

ISO/CEN PARALLEL PROCESSING

RECIPIENTS OF THIS DRAFT ARE INVITED TO SUBMIT, WITH THEIR COMMENTS, NOTIFICATION OF ANY RELEVANT PATENT RIGHTS OF WHICH THEY ARE AWARE AND TO PROVIDE SUPPORTING DOCUMENTATION.

IN ADDITION TO THEIR EVALUATION AS BEING ACCEPTABLE FOR INDUSTRIAL, TECHNOLOGICAL, COMMERCIAL AND USER PURPOSES, DRAFT INTERNATIONAL STANDARDS MAY ON OCCASION HAVE TO BE CONSIDERED IN THE LIGHT OF THEIR POTENTIAL TO BECOME STANDARDS TO WHICH REFERENCE MAY BE MADE IN NATIONAL REGULATIONS.



Reference number
ISO/FDIS 10297:2023(E)

© ISO 2023

iTeh Standards
(<https://standards.iteh.ai>)
Document Preview

ISO/FDIS 10297

<https://standards.iteh.ai/catalog/standards/sist/63f2ec4a-76ca-4df9-947d-56cbbd2d2729/iso-fdis-10297>



COPYRIGHT PROTECTED DOCUMENT

© ISO 2023

All rights reserved. Unless otherwise specified, or required in the context of its implementation, no part of this publication may be reproduced or utilized otherwise in any form or by any means, electronic or mechanical, including photocopying, or posting on the internet or an intranet, without prior written permission. Permission can be requested from either ISO at the address below or ISO's member body in the country of the requester.

ISO copyright office
CP 401 • Ch. de Blandonnet 8
CH-1214 Vernier, Geneva
Phone: +41 22 749 01 11
Email: copyright@iso.org
Website: www.iso.org

Published in Switzerland

Contents

	Page
Foreword.....	v
Introduction.....	vii
1 Scope.....	1
2 Normative references.....	2
3 Terms and definitions.....	2
4 Valve description.....	9
5 Valve design requirements.....	16
5.1 General.....	16
5.2 Materials.....	16
5.3 Valve connections.....	17
5.4 Mechanical strength.....	18
5.4.1 Resistance to hydraulic pressure.....	18
5.4.2 Resistance to mechanical impact.....	19
5.4.3 Resistance to valve spindle impact for pin-index valves.....	19
5.5 Valve operating mechanism.....	19
5.5.1 Opening and closing of the valve.....	19
5.5.2 Endurance.....	19
5.5.3 Resistance to excessive torques.....	20
5.5.4 Acetylene specific requirements.....	22
5.6 Valve operating device.....	23
5.6.1 Closing direction.....	23
5.6.2 Handwheel diameter.....	23
5.6.3 Exposure to flame.....	23
5.7 Leakage.....	23
5.8 Resistance to ignition.....	24
5.9 Flow capacity.....	25
6 Type testing.....	25
6.1 General.....	25
6.2 Test schedule.....	25
6.3 Documentation.....	28
6.4 Test samples.....	28
6.5 Test report.....	29
6.6 Test temperatures.....	29
6.7 Test pressures.....	29
6.7.1 Valve hydraulic test pressure.....	29
6.7.2 Valve test pressure.....	30
6.8 Test gases.....	30
6.8.1 Gas quality.....	30
6.8.2 Leak tightness tests.....	31
6.8.3 Endurance tests.....	31
6.8.4 Acetylene decomposition test.....	31
6.8.5 Oxygen pressure surge test.....	31
6.9 Hydraulic pressure test.....	31
6.10 Flame impingement test.....	32
6.11 Excessive torque tests.....	32
6.11.1 Handwheel operated valves.....	32
6.11.2 Key and toggle operated valves.....	32
6.11.3 VIPR type C with the flow selector acting as the primary valve operating mechanism and VIPR type B.....	33
6.12 Leak tightness tests.....	33
6.12.1 General.....	33
6.12.2 Internal leak tightness test.....	33

6.12.3	External leak tightness test.....	34
6.13	Endurance test.....	35
6.14	Endurance test of VIPR types B and C.....	36
6.15	Endurance test of the filling connection non-return valve.....	37
6.15.1	Filling connection non-return valve downstream of the valve operating mechanism.....	37
6.15.2	Filling connection non-return valve upstream of the valve operating mechanism.....	37
6.15.3	Test apparatus.....	38
6.16	Visual examination.....	39
6.17	Valve spindle impact test for pin-index valves.....	39
6.18	Pressure relief valve tightness test.....	39
7	Marking.....	40
Annex A	(normative) Impact test.....	41
Annex B	(normative) Tests for acetylene valves.....	43
Annex C	(normative) Oxygen pressure surge test.....	45
Annex D	(informative) Example of a vacuum test.....	53
Annex E	(normative) Endurance test machine.....	54
Annex F	(normative) Required tests for validation of changes and/or material variants within a valve design.....	56
Bibliography	59

iTeh Standards
 (https://standards.itih.ai)
 Document Preview

ISO/FDIS 10297

<https://standards.itih.ai/catalog/standards/sist/63f2ec4a-76ca-4df9-947d-56cbbd2d2729/iso-fdis-10297>

Foreword

ISO (the International Organization for Standardization) is a worldwide federation of national standards bodies (ISO member bodies). The work of preparing International Standards is normally carried out through ISO technical committees. Each member body interested in a subject for which a technical committee has been established has the right to be represented on that committee. International organizations, governmental and non-governmental, in liaison with ISO, also take part in the work. ISO collaborates closely with the International Electrotechnical Commission (IEC) on all matters of electrotechnical standardization.

The procedures used to develop this document and those intended for its further maintenance are described in the ISO/IEC Directives, Part 1. In particular, the different approval criteria needed for the different types of ISO document should be noted. This document was drafted in accordance with the editorial rules of the ISO/IEC Directives, Part 2 (see www.iso.org/directives).

ISO draws attention to the possibility that the implementation of this document may involve the use of (a) patent(s). ISO takes no position concerning the evidence, validity or applicability of any claimed patent rights in respect thereof. As of the date of publication of this document, ISO had not received notice of (a) patent(s) which may be required to implement this document. However, implementers are cautioned that this may not represent the latest information, which may be obtained from the patent database available at www.iso.org/patents. ISO shall not be held responsible for identifying any or all such patent rights.

Any trade name used in this document is information given for the convenience of users and does not constitute an endorsement.

For an explanation of the voluntary nature of standards, the meaning of ISO specific terms and expressions related to conformity assessment, as well as information about ISO's adherence to the World Trade Organization (WTO) principles in the Technical Barriers to Trade (TBT), see www.iso.org/iso/foreword.html.

This document was prepared by Technical Committee ISO/TC 58, *Gas cylinders*, Subcommittee SC 2, *Cylinder fittings*, in collaboration with the European Committee for Standardization (CEN) Technical Committee CEN/TC 23, *Transportable gas cylinders*, in accordance with the Agreement on technical cooperation between ISO and CEN (Vienna Agreement).

This fourth edition cancels and replaces the third edition (ISO 10297:2014), which has been technically revised. It also incorporates the Amendment ISO 10297:2014/Amd. 1:2017.

The main changes are as follows:

- clarification of the scope concerning different VIPR designs;
- addition of several new terms and definitions, e.g. VIPR types A, B and C for easy referencing of different design types;
- oxygen pressure surge test:
 - for VIPR's transferred from ISO 22435 and amended,
 - for RPV's transferred from ISO 15996 and amended,
 - reference for test equipment and procedure to ISO 11114-6,
- endurance test for specific VIPR designs transferred from ISO 22435 and amended;
- endurance test of the filling connection non-return valve transferred from ISO 22435 with clarification of the test procedure without changes to the acceptance criteria;
- acetylene decomposition test of VIPR designs transferred from ISO 22435 and amended;

ISO/FDIS 10297:2023(E)

- subclause 5.3 "Dimensions" removed;
- introduction of [Table 2](#) for giving the different leakage rates depending on the valve design;
- [Table 4](#) (former [Table 3](#)) amended;
- introduction of recommendations for flow capacity values and reference to CGA V-9 for the respective determination as an example;
- introduction of a valve spindle impact test for pin-index valves not permanently protected during transport and use;
- introduction of the hydraulic pressure test also in the closed position for manually operated valves;
- introduction of an additional tightness test for pressure relief valves located upstream of the valve operating mechanism;
- Annex D "Example of test schedule" removed;
- information on changes and/or material variants within a valve design moved to new [Annex F](#) and amended.

Any feedback or questions on this document should be directed to the user's national standards body. A complete listing of these bodies can be found at www.iso.org/members.html.

iTeh Standards (<https://standards.iteh.ai>) Document Preview

[ISO/FDIS 10297](#)

<https://standards.iteh.ai/catalog/standards/sist/63f2ec4a-76ca-4df9-947d-56cbbd2d2729/iso-fdis-10297>

Introduction

This document has been written so that it is suitable to be referenced in the UN Model Regulations.

The term “pressure receptacle” is used within this document to cover instances where no differentiation is necessary between gas cylinders, bundles of cylinders, pressure drums and tubes.

In this document, the unit bar is used, due to its universal use in the field of technical gases. It should, however, be noted that bar is not an SI unit, and that the corresponding SI unit for pressure is Pa (1 bar = 10^5 Pa = 10^5 N/m²).

Pressure values given in this document are given as gauge pressure (pressure exceeding atmospheric pressure) unless noted otherwise.

Any tolerances given in this document include measurement uncertainties.

iTeh Standards (<https://standards.iteh.ai>) Document Preview

[ISO/FDIS 10297](https://standards.iteh.ai/catalog/standards/sist/63f2ec4a-76ca-4df9-947d-56cbbd2d2729/iso-fdis-10297)

<https://standards.iteh.ai/catalog/standards/sist/63f2ec4a-76ca-4df9-947d-56cbbd2d2729/iso-fdis-10297>

Gas cylinders — Cylinder valves — Specification and type testing

1 Scope

This document specifies design, type testing and marking requirements for:

- a) cylinder valves intended to be fitted to refillable transportable gas cylinders;
- b) main valves (excluding ball valves) for bundles of cylinders;
- c) cylinder valves or main valves with integrated pressure regulator (VIPR);

NOTE 1 This includes the following specific VIPR designs where:

- 1) The pressure regulating system is acting as the primary valve operating mechanism (VIPR type B). This also includes designs where closure of the primary valve operating mechanism is obtained by closing the seat of the pressure regulating mechanism.
- 2) The primary valve operating mechanism is located at the low-pressure side of the pressure regulating system (VIPR type C).

- d) valves for pressure drums and tubes;

which convey compressed, liquefied or dissolved gases.

NOTE 2 Where there is no risk of ambiguity, cylinder valves, main valves, VIPR's and valves for pressure drums and tubes are addressed with the collective term "valves" within this document.

This document does not apply to

- valves for cryogenic equipment, portable fire extinguishers and liquefied petroleum gas (LPG);
- quick-release cylinder valves (e.g. for fire-extinguishing, explosion protection and rescue applications) - requirements for quick-release cylinder valves are specified in ISO 17871 which contains normative references to this document;
- self-closing cylinder valves or ball valves.

NOTE 3 Requirements for valves for cryogenic vessels are specified in ISO 21011 and at a regional level, e.g. in EN 1626. Requirements for LPG valves are specified in ISO 14245 or ISO 15995. Requirements for self-closing cylinder valves are specified in ISO 17879. Requirements for ball valves are specified in ISO 23826. Requirements for valves for portable fire extinguishers at a regional level are specified, for example, in the EN 3 series.

This document only covers the function of a valve as a closure. Other functions that are possibly integrated in the valve can be covered by other standards. Such standards do however not constitute requirements according to this document.

NOTE 4 Definition of and specific requirements for VIPR's in addition to those that are given in this document are specified in ISO 22435 for industrial applications or ISO 10524-3 for medical applications. Similarly, certain specific requirements for residual pressure valves (RPV) with or without a non-return function in addition to those that are given in this document are given in ISO 15996.

NOTE 5 Certain specific requirements for valves for breathing apparatus in addition to those that are given in this document are specified at a regional level, for example, in the EN 144 series. Certain specific requirements for quick-release valves for fixed fire-fighting systems in addition to those that are given in this document are specified in ISO 16003 and at a regional level, for example, in EN 12094-4.

NOTE 6 Requirements for manufacturing tests and examinations of valves covered by this document are given in ISO 14246.

2 Normative references

The following documents are referred to in the text in such a way that some or all of their content constitutes requirements of this document. For dated references, only the edition cited applies. For undated references, the latest edition of the referenced document (including any amendments) applies.

ISO 148-1, *Metallic materials — Charpy pendulum impact test — Part 1: Test method*

ISO 10286, *Gas cylinders — Vocabulary*

ISO 11114-1, *Gas cylinders — Compatibility of cylinder and valve materials with gas contents — Part 1: Metallic materials*

ISO 11114-2, *Gas cylinders — Compatibility of cylinder and valve materials with gas contents — Part 2: Non-metallic materials*

ISO 11114-6, *Gas cylinders — Compatibility of cylinder and valve materials with gas contents — Part 6: Oxygen pressure surge testing*

ISO 11117, *Gas cylinders — Valve protection caps and guards — Design, construction and tests*

ISO/TR 11364, *Gas cylinders — Compilation of national and international valve stem/gas cylinder neck threads and their identification and marking system*

ISO 13341, *Gas cylinders — Fitting of valves to gas cylinders*

ISO 15615:2022, *Gas welding equipment — Acetylene manifold systems for welding, cutting and allied processes — Safety requirements in high-pressure devices*

3 Terms and definitions

For the purposes of this document, the terms and definitions given in ISO 10286 and the following apply.

ISO and IEC maintain terminology databases for use in standardization at the following addresses:

- ISO Online browsing platform: available at <https://www.iso.org/obp>
- IEC Electropedia: available at <https://www.electropedia.org/>

3.1 valve design

classification of valves with regard to the *valve operating mechanism* (3.10)

3.2 main valve

valve which is fitted to the manifold of a bundle of cylinders, battery vehicle, battery wagon or multiple-element gas containers (MEGC) isolating it from the main connection(s)

3.3 residual pressure valve

RPV
valve which incorporates a *residual pressure device* (3.4)

**3.4 residual pressure device
RPD**

device that is designed to prevent ingress of contaminants by maintaining a positive pressure within the pressure receptacle relative to atmosphere by closing off its internal gas passages in the discharging direction

Note 1 to entry: This definition can be different to definitions given in applicable transport regulations.

**3.5 valve with integrated pressure regulator
VIPR**

device intended to be permanently fitted to a pressure receptacle which comprises of at least a shut-off function and pressure regulating system

Note 1 to entry: A VIPR used as a *main valve* (3.2) is covered by this definition.

3.6 VIPR type A

VIPR design where the primary *valve operating mechanism* (3.10) is located upstream of the *pressure regulating system* (3.9)

Note 1 to entry: For typical designs, see [Figure 1](#).

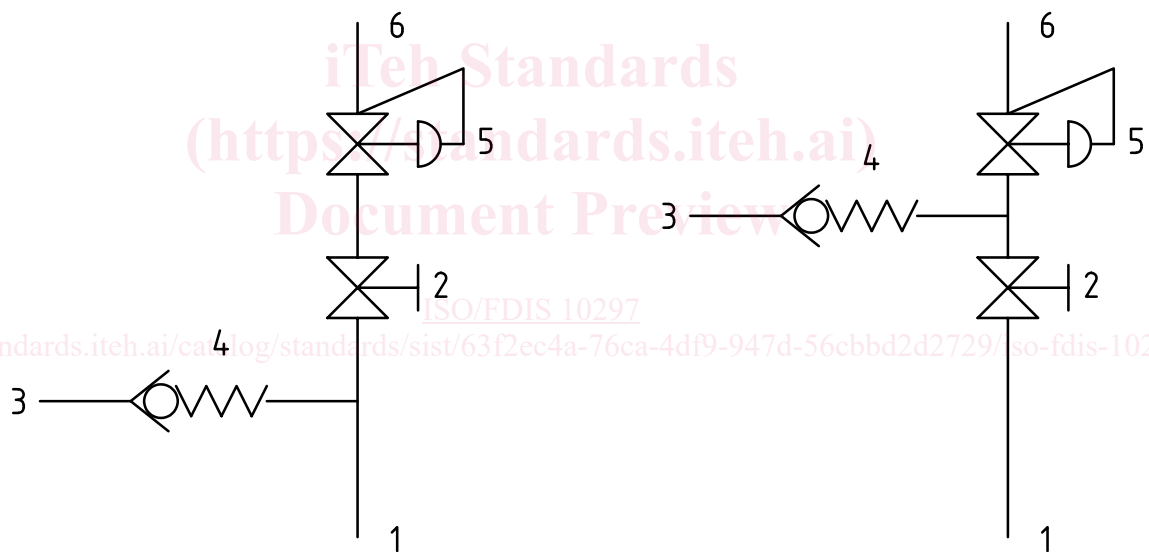

a) Valve filling connection upstream of the primary valve operating mechanism

b) Valve filling connection between the primary valve operating mechanism and the pressure regulating system

Key

- | | |
|-------------------------------------|-------------------------------------|
| 1 valve inlet connection | 4 filling connection closing device |
| 2 primary valve operating mechanism | 5 pressure regulating system |
| 3 valve filling connection | 6 valve outlet connection |

Figure 1 — General structure of VIPR type A designs

3.7

VIPR type B

VIPR design where the *pressure regulating system* (3.9) is also acting as the *primary valve operating mechanism* (3.10)

Note 1 to entry: See [Figure 2](#).

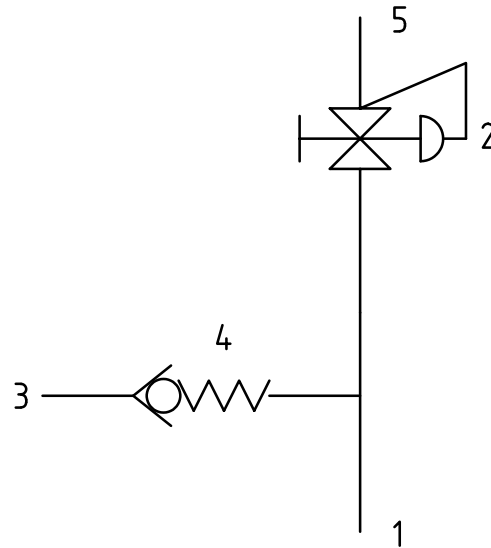

Key

- | | | | |
|---|--|---|-----------------------------------|
| 1 | valve inlet connection | 4 | filling connection closing device |
| 2 | pressure regulating system including primary valve operating mechanism | 5 | valve outlet connection |
| 3 | valve filling connection | | |

Figure 2 — General structure of a VIPR type B design

[ISO/FDIS 10297](#)

3.8

VIPR type C

VIPR design where the *primary valve operating mechanism* (3.10) is located downstream of the *pressure regulating system* (3.9)

Note 1 to entry: The primary valve operating mechanism can be a flow selector.

Note 2 to entry: See [Figure 3](#).

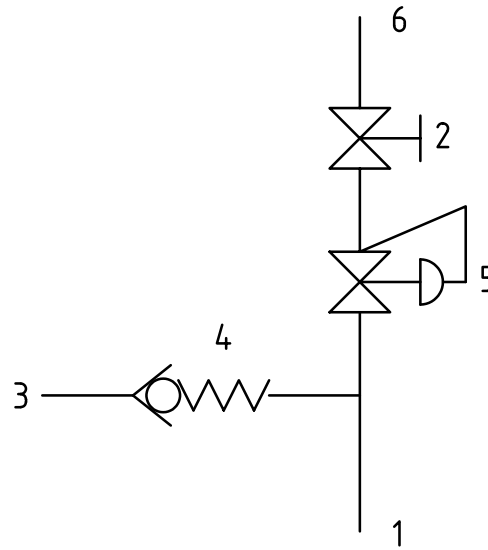
**Key**

- | | | | |
|---|-----------------------------------|---|-----------------------------------|
| 1 | valve inlet connection | 4 | filling connection closing device |
| 2 | primary valve operating mechanism | 5 | pressure regulating system |
| 3 | valve filling connection | 6 | valve outlet connection |

Figure 3 — General structure of a VIPR type C design

3.9 pressure regulating system device(s) that reduce(s) the inlet pressure to a controlled outlet pressure

Note 1 to entry: A pressure regulating system can comprise of one or more stages of pressure regulation.

Note 2 to entry: The pressure regulating system can be either adjustable (adjustable pressure setting) or pre-set (fixed pressure setting).

3.10 valve operating mechanism

mechanism which closes and opens the valve orifice, and which includes the internal and external sealing systems

EXAMPLE A threaded valve spindle which, when rotated, raises and lowers a seal/seat.

Note 1 to entry: For a VIPR, the valve operating mechanism is called the primary valve operating mechanism.

Note 2 to entry: For a VIPR type B, the pressure regulating system is also acting as the primary valve operating mechanism.

3.11 valve operating device

component which actuates the *valve operating mechanism* (3.10)

EXAMPLE Handwheel (including knob), key, toggle, lever or actuator.

3.12 external leak tightness

leak tightness to atmosphere (leakage in and/or leakage out) when the valve is open

Note 1 to entry: The total external leakage typically comprises that from the valve external sealing system plus, for example, pressure relief device, RPD, pressure indicating devices and pressure regulating system.

Note 2 to entry: See [Figure 4](#).

Note 3 to entry: Leakage in describes a leak resulting in a flow direction into the valve during vacuum testing. Leakage out describes a leak resulting in a flow direction out of the valve.

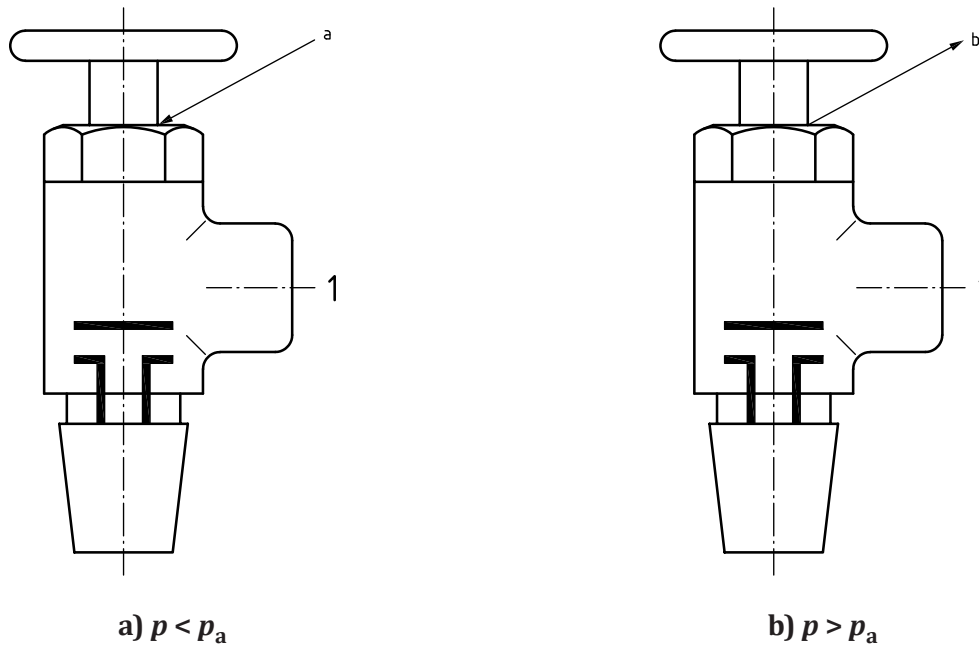

Key

- 1 valve outlet connection (sealed)
- p internal pressure
- p_a atmospheric pressure
- ^a Leakage in (vacuum test).
- ^b Leakage out.

iTeh Standards
 (https://standards.itih.ai)
 Document Preview

Figure 4 — External leak tightness

<https://standards.itih.ai/catalog/standards/sist/63f2ec4a-76ca-4d19-947d-56cbbd2d2729/iso-fdis-10297>

3.13 internal leak tightness

leak tightness across the valve seat (leakage in and/or leakage out) when the valve is closed

Note 1 to entry: See [Figure 5](#).

Note 2 to entry: Leakage in describes a leak resulting in a flow direction into the valve during vacuum testing. Leakage out describes a leak resulting in a flow direction out of the valve.