

FINAL
DRAFT

INTERNATIONAL
STANDARD

ISO/FDIS
22435

ISO/TC 58/SC 2

Secretariat: AFNOR

Voting begins on:
2023-12-13

Voting terminates on:
2024-02-07

Gas cylinders — Cylinder valves with integrated pressure regulators — Specification and type testing

*Bouteilles à gaz — Robinets de bouteilles avec détendeur intégré —
Spécifications et essais de type*

iTeh Standards
(<https://standards.iteh.ai>)
Document Preview

[ISO/FDIS 22435](https://standards.iteh.ai/catalog/standards/sist/cad7be8c-c4fc-4adf-8632-49e85ae41640/iso-fdis-22435)

<https://standards.iteh.ai/catalog/standards/sist/cad7be8c-c4fc-4adf-8632-49e85ae41640/iso-fdis-22435>

ISO/CEN PARALLEL PROCESSING

RECIPIENTS OF THIS DRAFT ARE INVITED TO SUBMIT, WITH THEIR COMMENTS, NOTIFICATION OF ANY RELEVANT PATENT RIGHTS OF WHICH THEY ARE AWARE AND TO PROVIDE SUPPORTING DOCUMENTATION.

IN ADDITION TO THEIR EVALUATION AS BEING ACCEPTABLE FOR INDUSTRIAL, TECHNOLOGICAL, COMMERCIAL AND USER PURPOSES, DRAFT INTERNATIONAL STANDARDS MAY ON OCCASION HAVE TO BE CONSIDERED IN THE LIGHT OF THEIR POTENTIAL TO BECOME STANDARDS TO WHICH REFERENCE MAY BE MADE IN NATIONAL REGULATIONS.



Reference number
ISO/FDIS 22435:2023(E)

© ISO 2023

iTeh Standards
(<https://standards.iteh.ai>)
Document Preview

[ISO/FDIS 22435](https://standards.iteh.ai/catalog/standards/sist/cad7be8c-c4fc-4adf-8632-49e85ae41640/iso-fdis-22435)

<https://standards.iteh.ai/catalog/standards/sist/cad7be8c-c4fc-4adf-8632-49e85ae41640/iso-fdis-22435>



COPYRIGHT PROTECTED DOCUMENT

© ISO 2023

All rights reserved. Unless otherwise specified, or required in the context of its implementation, no part of this publication may be reproduced or utilized otherwise in any form or by any means, electronic or mechanical, including photocopying, or posting on the internet or an intranet, without prior written permission. Permission can be requested from either ISO at the address below or ISO's member body in the country of the requester.

ISO copyright office
CP 401 • Ch. de Blandonnet 8
CH-1214 Vernier, Geneva
Phone: +41 22 749 01 11
Email: copyright@iso.org
Website: www.iso.org

Published in Switzerland

Contents

	Page
Foreword.....	v
Introduction.....	vii
1 Scope.....	1
2 Normative references.....	1
3 Terms and definitions.....	2
4 Symbols and descriptions.....	6
5 Design requirements and considerations.....	7
5.1 General.....	7
5.2 Description.....	7
5.3 Materials.....	8
5.4 Pressure and flow indicating devices.....	8
5.4.1 General.....	8
5.4.2 Flowmeters.....	8
5.4.3 Pressure indicators and flow gauges.....	8
5.5 Outlet connection.....	9
5.6 Outlet pressure for acetylene.....	9
5.7 Flow control valve (flow controller).....	9
5.8 Pressure adjusting device.....	9
5.9 Filtration.....	9
5.10 Endurance of the VIPR pressure regulating system.....	9
5.11 Flow and pressure performance for a VIPR with a pressure outlet.....	10
5.11.1 Flow performance and characteristics.....	10
5.11.2 Coefficient of pressure increase upon closure R	10
5.11.3 Irregularity coefficient i	10
5.12 Flow performance for a VIPR with a flow metering device.....	10
5.13 Pressure relief valve.....	10
5.14 Leakage.....	11
5.15 Mechanical strength.....	11
5.16 Pressure resistance.....	11
5.17 Resilience to ignition.....	11
5.18 Design requirements for manufacture.....	12
5.19 Resistance to vibration.....	12
5.20 Resistance to shock.....	12
5.21 Over torque of the pressure adjusting device.....	12
6 Type testing.....	13
6.1 General.....	13
6.2 Documentation.....	13
6.3 Test samples.....	14
6.4 Test report.....	14
6.5 Test temperatures.....	14
6.6 Test gas.....	14
6.6.1 Gas quality.....	14
6.6.2 Reference conditions.....	14
6.6.3 Leak tightness tests.....	14
6.6.4 Endurance of a VIPR pressure regulating system.....	15
6.7 Test schedule.....	15
6.8 Mechanical strength test of the low-pressure chamber.....	16
6.9 Pressure resistance test of the low-pressure chamber.....	16
6.10 Mechanical strength test of flowmeters.....	16
6.11 Overpressure and leak tightness test for pressure indicators and flow gauges.....	17
6.12 Flow and pressure performance test for a VIPR with a pressure outlet.....	17
6.12.1 General.....	17

6.12.2	Standard discharge, Q_1 , nominal outlet pressure, p_2 , and maximum discharge Q_{\max} test.....	17
6.12.3	Flow characteristic test.....	18
6.12.4	Coefficient of pressure increase upon closure R test.....	20
6.12.5	Irregularity coefficient i test.....	20
6.13	Accuracy and flow stability of a VIPR with a flow metering device test.....	23
6.14	Pressure relief valve test.....	23
6.15	Operating and loosening torques test.....	23
6.16	Endurance of the VIPR pressure regulating system.....	24
6.17	Leak tightness test.....	24
6.17.1	Number of samples.....	24
6.17.2	Internal leakage across the regulating valve seat.....	25
6.17.3	External leakage.....	25
6.18	Visual examination.....	25
7	Marking	25
8	Instructions	26
Annex A	(informative) Vibration test	27
Annex B	(informative) Shock test	28
Annex C	(informative) Over torque test for the pressure adjusting device	29
Annex D	(informative) Promoted ignition test	30
Bibliography	31

ITeh Standards
(<https://standards.iteh.ai>)
Document Preview

[ISO/FDIS 22435](https://standards.iteh.ai/catalog/standards/sist/cad7be8c-c4fc-4adf-8632-49e85ae41640/iso-fdis-22435)

<https://standards.iteh.ai/catalog/standards/sist/cad7be8c-c4fc-4adf-8632-49e85ae41640/iso-fdis-22435>

Foreword

ISO (the International Organization for Standardization) is a worldwide federation of national standards bodies (ISO member bodies). The work of preparing International Standards is normally carried out through ISO technical committees. Each member body interested in a subject for which a technical committee has been established has the right to be represented on that committee. International organizations, governmental and non-governmental, in liaison with ISO, also take part in the work. ISO collaborates closely with the International Electrotechnical Commission (IEC) on all matters of electrotechnical standardization.

The procedures used to develop this document and those intended for its further maintenance are described in the ISO/IEC Directives, Part 1. In particular, the different approval criteria needed for the different types of ISO document should be noted. This document was drafted in accordance with the editorial rules of the ISO/IEC Directives, Part 2 (see www.iso.org/directives).

ISO draws attention to the possibility that the implementation of this document may involve the use of (a) patent(s). ISO takes no position concerning the evidence, validity or applicability of any claimed patent rights in respect thereof. As of the date of publication of this document, ISO had not received notice of (a) patent(s) which may be required to implement this document. However, implementers are cautioned that this may not represent the latest information, which may be obtained from the patent database available at www.iso.org/patents. ISO shall not be held responsible for identifying any or all such patent rights.

Any trade name used in this document is information given for the convenience of users and does not constitute an endorsement.

For an explanation of the voluntary nature of standards, the meaning of ISO specific terms and expressions related to conformity assessment, as well as information about ISO's adherence to the World Trade Organization (WTO) principles in the Technical Barriers to Trade (TBT), see www.iso.org/iso/foreword.html.

This document was prepared by Technical Committee ISO/TC 58, *Gas cylinders*, Subcommittee SC 2, *Cylinder fittings*, in collaboration with the European Committee for Standardization (CEN) Technical Committee CEN/TC 23, *Transportable gas cylinders*, in accordance with the Agreement on technical cooperation between ISO and CEN (Vienna Agreement).

This second edition cancels and replaces the first edition (ISO 22435:2007), which has been technically revised. It also incorporates the Amendment ISO 22435:2007/Amd. 1:2012.

The main changes are as follows:

- Introduction: clarification that this document gives additional requirements to those specified in ISO 10297, ISO 17871, ISO 17879 and ISO 23826, unless specifically mentioned.
- Scope:
 - requirements in this document are in addition to those specified in ISO 10297, ISO 17871, ISO 17879 and ISO 23826, unless specifically mentioned;
 - clarification of different VIPR types with different positions of primary operating mechanism within the valve;
 - exclusion of VIPRs for liquefied petroleum gas (LPG) and cryogenic applications.
- Terms and definitions: definition of a primary valve operating mechanism.
- Introduction of VIPR types A, B and C for easy referencing of different design types.

ISO/FDIS 22435:2023(E)

- Symbols and descriptions:
 - clarification of inlet pressure to the regulating function p_1 and valve test pressure for different gas types;
 - additional characteristic column in table with link to test method, if relevant.
- Design requirements and considerations:
 - general: VIPRs to comply with the relevant closure standards;
 - materials: lubricant requirements given in relevant closure standard;
 - pressure and flow indicating devices: relevant pressure indicator requirements in this document;
 - cylinder connection: clause removed;
 - main shut-off valve: clause removed because requirements already given in relevant closure standard;
 - pressure adjusting device: addition of a new clause;
 - leakage: total external and internal leakage shall not exceed 12 cm³/h;
 - mechanical strength: mechanical strength of inlet side moved to relevant closure standard;
 - resistance to ignition: moved to ISO 10297;
 - resilience to ignition: addition of a new clause;
 - resistance to vibration and shock: addition of a new clause.
- Type testing:
 - general: clarification of changes to the VIPR design that require repetition of type tests;
 - test schedule: table reformatted for relevant tests;
 - test method for accuracy of VIPR with flowmeter: reference standard changed to ISO 2503;
 - test methods for leakage: test for regulating device only;
 - test method for the endurance test of the VIPR with the pressure regulator valve acting as primary valve operating mechanism: moved to ISO 10297;
 - test method for endurance of the filling connection closing device: moved to ISO 10297;
 - test method for VIPR pressure regulator endurance test: addition of new test.
- Removal of previous Annex A "Valve impact test" and Annex B "Endurance test", because both are already given in relevant closure standards.
- Addition of new [Annexes A, B, C and D](#).

Any feedback or questions on this document should be directed to the user's national standards body. A complete listing of these bodies can be found at www.iso.org/members.html.

Introduction

Valves with integrated pressure regulators (VIPRs) are used to reduce the pressure receptacle pressure to a lower pressure suitable for end use processes.

VIPRs incorporate the basic functionality of a primary valve operating mechanism, with the additional ability to regulate the pressure and/or flow at the valve outlet. They remove the need for end users to make and break a high-pressure gas connection.

These valves operate over a wide range of inlet and outlet pressures and flows which require specific design characteristics. It is important that the operating characteristics of these valves be specified and tested in a defined manner.

Such valves are more complicated than conventional cylinder valves yet subject to the same environmental and transport conditions. These conditions should be kept in mind at the design and development stage.

This document gives additional requirements for VIPRs to those given for cylinder valves in general in ISO 10297, for quick-release cylinder valves in ISO 17871, for self-closing cylinder valves in ISO 17879 or for ball valves in ISO 23826.

This document focusses on:

- a) suitability of materials;
- b) safety (mechanical strength, safe relief of excess pressure, etc.);
- c) gas-specificity;
- d) cleanliness;
- e) testing;
- f) identification;
- g) information supplied.

When a VIPR has been tested according to the previous version of this document, the organisation responsible for testing the same VIPR to this document should consider which tests need to be performed.

In this document, the unit bar is used, due to its universal use in the field of technical gases. Bar is not an SI unit and the corresponding SI unit for pressure is Pa (1 bar = 10^5 Pa = 10^5 N/m²).

Pressure values given in this document are given as gauge pressure (pressure exceeding atmospheric pressure) unless noted otherwise.

Tests and examinations performed to demonstrate compliance with this document are conducted using instruments calibrated before being put into service and thereafter according to an established programme.

Any tolerances given in this document include measurement uncertainties.

Gas cylinders — Cylinder valves with integrated pressure regulators — Specification and type testing

1 Scope

This document specifies design, type test methods, marking and instruction requirements for cylinder valves with integrated pressure regulators (VIPRs) intended to be fitted to gas cylinders, pressure drums or tubes or used as a main valve for bundles of cylinders that convey compressed, liquefied or dissolved gases.

These are requirements for VIPRs that are in addition to those given in the relevant closure standard, for example, in ISO 10297 for cylinder valves, in ISO 17871 for quick-release cylinder valves, in ISO 17879 for self-closing cylinder valves or in ISO 23826 for ball valves. For ISO 17871, these requirements are only applicable to quick-release cylinder valves types B, C, D and E.

NOTE 1 If the pressure regulating system of a VIPR is acting as the primary valve operating mechanism, it is covered by the relevant closure standard, e.g. ISO 10297, ISO 17871, ISO 17879 and ISO 23826. This also includes designs where closure of the primary valve operating mechanism of a VIPR is obtained by closing the seat of the pressure regulating system.

NOTE 2 If the primary valve operating mechanism of a VIPR is located at the low-pressure side of the pressure regulating system, it is covered by the relevant closure standard, e.g. ISO 10297, ISO 17871, ISO 17879 and ISO 23826.

NOTE 3 The term “pressure receptacle” is used within this document to cover instances where no differentiation is necessary between gas cylinders, bundles of cylinders, pressure drums and tubes.

This document does not apply to VIPRs for

a) medical applications (see ISO 10524-3); <https://standards.iteh.ai/catalog/standards/sist/cad7be8c-c4fc-4adf-8632-49e85ae41640/iso-fdis-22435>

b) liquefied petroleum gas (LPG);

c) cryogenic applications.

NOTE 4 Additional requirements for a VIPR with a residual pressure device (RPD) are specified in ISO 15996.

NOTE 5 Additional requirements for pressure relief valves can exist in international/regional regulations/standards.

2 Normative references

The following documents are referred to in the text in such a way that some or all of their content constitutes requirements of this document. For dated references, only the edition cited applies. For undated references, the latest edition of the referenced document (including any amendments) applies.

ISO 5171:2019, *Gas welding equipment — Pressure gauges used in welding, cutting and allied processes*

ISO 2503:2009, *Gas welding equipment — Pressure regulators and pressure regulators with flow-metering devices for gas cylinders used in welding, cutting and allied processes up to 300 bar (30 MPa)*

ISO 7289, *Gas welding equipment — Quick-action couplings with shut-off valves for welding, cutting and allied processes*

ISO 9090, *Gas tightness of equipment for gas welding and allied processes*

ISO 10156, *Gas cylinders — Gases and gas mixtures — Determination of fire potential and oxidizing ability for the selection of cylinder valve outlets*

ISO 10225, *Gas welding equipment — Marking for equipment used for gas welding, cutting and allied processes*

ISO 10286, *Gas cylinders — Vocabulary*

ISO 10297, *Gas cylinders — Cylinder valves — Specification and type testing*

ISO 17871, *Gas cylinders — Quick-release cylinder valves — Specification and type testing*

ISO 17879, *Gas cylinders — Self-closing cylinder valves — Specification and type testing*

ISO 23826, *Gas cylinders — Ball valves — Specification and testing*

ISO/TR 28821, *Gas welding equipment — Hose connections for equipment for welding, cutting and allied processes — Listing of connections which are either standardised or in common use*

3 Terms and definitions

For the purposes of this document, the terms and definitions given in ISO 10286, ISO 10297, ISO 2503 and the following apply.

ISO and IEC maintain terminology databases for use in standardization at the following addresses:

— ISO Online browsing platform: available at <https://www.iso.org/obp>

— IEC Electropedia: available at <https://www.electropedia.org/>

3.1 valve with integrated pressure regulator VIPR

device intended to be permanently fitted to a pressure receptacle which comprises of at least a shut-off function and pressure regulating system

3.2 VIPR type A

VIPR (3.1) design where the *primary valve operating mechanism* (3.5) is located upstream of the *pressure regulating system* (3.7)

Note 1 to entry: For typical designs, see [Figure 1](#). The filling connection can also be located between the primary valve operating mechanism and the pressure regulating system.

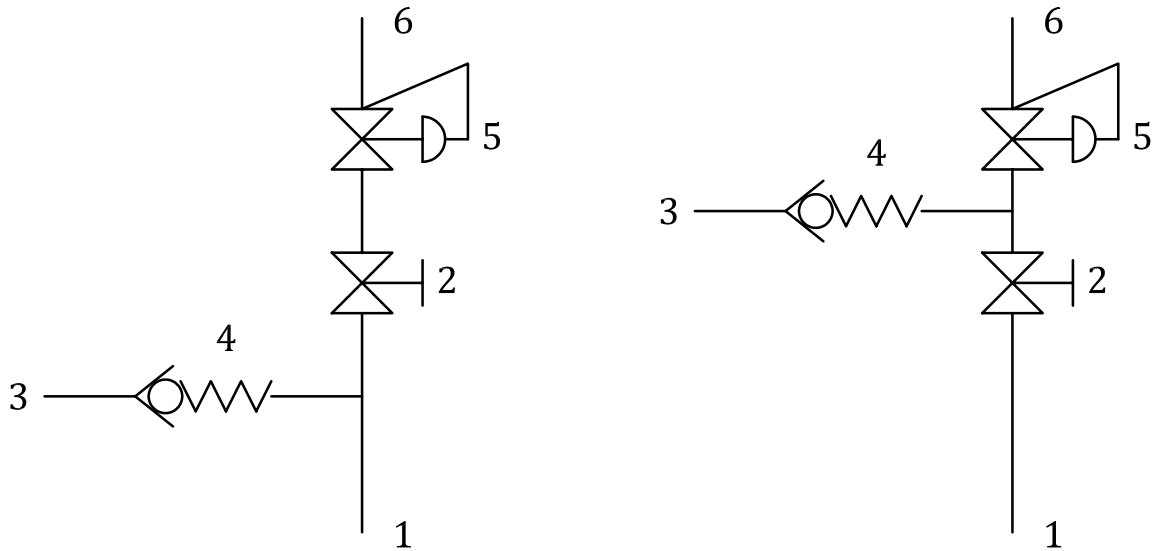

a) Filling connection upstream of the primary valve operating mechanism

b) Filling connection between the primary valve operating mechanism and the pressure regulating system

Key

- | | |
|-------------------------------------|-------------------------------------|
| 1 valve inlet connection | 4 filling connection closing device |
| 2 primary valve operating mechanism | 5 pressure regulating system |
| 3 valve filling connection | 6 valve outlet connection |

Figure 1 — General structure of a VIPR type A design

3.3

VIPR type B

VIPR design where the *pressure regulating system* (3.5) is also acting as the *primary valve operating mechanism* (3.7)

Note 1 to entry: See [Figure 2](#).

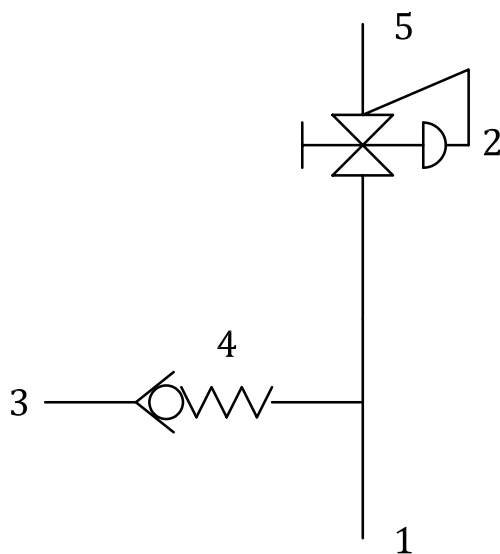

Key

- | | | | |
|---|--|---|-----------------------------------|
| 1 | valve inlet connection | 4 | filling connection closing device |
| 2 | pressure regulating system including primary valve operating mechanism | 5 | valve outlet connection |
| 3 | valve filling connection | | |

Figure 2 — General structure of a VIPR type B design

**3.4
VIPR type C**

VIPR design where the *primary valve operating mechanism* (3.5) is located downstream of the *pressure regulating system* (3.7)

ISO/FDIS 22435

Note 1 to entry: The primary valve operating mechanism can be a flow selector.

Note 2 to entry: See [Figure 3](#).