

---

---

**Soft soldering fluxes — Test  
methods —**

**Part 9:  
Determination of ammonia content**

*Flux de brasage tendre — Méthodes d'essai —*

*Partie 9: Dosage de l'ammoniac*  
**iTeh STANDARD PREVIEW  
(standards.iteh.ai)**

ISO 9455-9:2020

<https://standards.iteh.ai/catalog/standards/sist/eb9d3108-22c8-482f-80d8-8c69e461f623/iso-9455-9-2020>



## iTeh STANDARD PREVIEW (standards.iteh.ai)

ISO 9455-9:2020

<https://standards.iteh.ai/catalog/standards/sist/eb9d3108-22c8-482f-80d8-8c69e461f623/iso-9455-9-2020>



### **COPYRIGHT PROTECTED DOCUMENT**

© ISO 2020

All rights reserved. Unless otherwise specified, or required in the context of its implementation, no part of this publication may be reproduced or utilized otherwise in any form or by any means, electronic or mechanical, including photocopying, or posting on the internet or an intranet, without prior written permission. Permission can be requested from either ISO at the address below or ISO's member body in the country of the requester.

ISO copyright office  
CP 401 • Ch. de Blandonnet 8  
CH-1214 Vernier, Geneva  
Phone: +41 22 749 01 11  
Email: [copyright@iso.org](mailto:copyright@iso.org)  
Website: [www.iso.org](http://www.iso.org)

Published in Switzerland

# Contents

	Page
Foreword .....	iv
<b>1 Scope</b> .....	<b>1</b>
<b>2 Normative reference</b> .....	<b>1</b>
<b>3 Terms and definitions</b> .....	<b>1</b>
<b>4 Principle</b> .....	<b>1</b>
<b>5 Reagents</b> .....	<b>1</b>
<b>6 Apparatus</b> .....	<b>2</b>
<b>7 Procedure</b> .....	<b>2</b>
7.1 General .....	2
7.2 Preparation of flux test solution .....	2
7.2.1 Solid fluxes .....	2
7.2.2 Paste fluxes .....	2
7.2.3 Liquid fluxes .....	2
7.3 Determinations .....	3
<b>8 Calculation of results</b> .....	<b>4</b>
8.1 Solid or paste flux samples .....	4
8.2 Liquid flux samples .....	4
<b>9 Precision</b> .....	<b>4</b>
9.1 General .....	4
9.2 Precision data .....	4
<b>10 Test report</b> .....	<b>5</b>
<b>Bibliography</b> .....	<b>6</b>

iTech STANDARD PREVIEW

(standards.iteh.ai)

[ISO 9455-9:2020](https://standards.iteh.ai/catalog/standards/sist/eb9d3108-22c8-482f-80d8-8c69e461f623/iso-9455-9-2020)

<https://standards.iteh.ai/catalog/standards/sist/eb9d3108-22c8-482f-80d8-8c69e461f623/iso-9455-9-2020>

## Foreword

ISO (the International Organization for Standardization) is a worldwide federation of national standards bodies (ISO member bodies). The work of preparing International Standards is normally carried out through ISO technical committees. Each member body interested in a subject for which a technical committee has been established has the right to be represented on that committee. International organizations, governmental and non-governmental, in liaison with ISO, also take part in the work. ISO collaborates closely with the International Electrotechnical Commission (IEC) on all matters of electrotechnical standardization.

The procedures used to develop this document and those intended for its further maintenance are described in the ISO/IEC Directives, Part 1. In particular, the different approval criteria needed for the different types of ISO documents should be noted. This document was drafted in accordance with the editorial rules of the ISO/IEC Directives, Part 2 (see [www.iso.org/directives](http://www.iso.org/directives)).

Attention is drawn to the possibility that some of the elements of this document may be the subject of patent rights. ISO shall not be held responsible for identifying any or all such patent rights. Details of any patent rights identified during the development of the document will be in the Introduction and/or on the ISO list of patent declarations received (see [www.iso.org/patents](http://www.iso.org/patents)).

Any trade name used in this document is information given for the convenience of users and does not constitute an endorsement.

For an explanation of the voluntary nature of standards, the meaning of ISO specific terms and expressions related to conformity assessment, as well as information about ISO's adherence to the World Trade Organization (WTO) principles in the Technical Barriers to Trade (TBT), see [www.iso.org/iso/foreword.html](http://www.iso.org/iso/foreword.html).

This document was prepared by Technical Committee ISO TC 44, *Welding and allied processes*, Sub-Committee SC 12, *Soldering materials*, in collaboration with the European Committee for Standardization (CEN) Technical Committee CEN/TC 121, *Welding and allied processes*, in accordance with the Agreement on technical cooperation between ISO and CEN (Vienna Agreement).

This second edition cancels and replaces the first edition (ISO 9455-9:1993), of which it constitutes a minor revision.

The main changes compared to the previous edition are as follows:

- [Clause 2](#) has been updated;
- new [Clause 3](#), Terms and definitions, has been inserted;
- the coding of the fluxes has been updated in accordance with ISO 9454-1:2016.

A list of all parts in the ISO 9455 series can be found on the ISO website.

Any feedback or questions on this document should be directed to the user's national standards body. A complete listing of these bodies can be found at [www.iso.org/members.html](http://www.iso.org/members.html).

Official interpretations of ISO/TC 44 documents, where they exist, are available from this page: <https://committee.iso.org/sites/tc44/home/interpretation.html>.

# Soft soldering fluxes — Test methods —

## Part 9: Determination of ammonia content

### 1 Scope

This document specifies a distillation method for the determination of the ammonia content of solid, paste or liquid fluxes. The method is applicable to fluxes of class 311 and 321 only, as defined in ISO 9454-1.

### 2 Normative reference

There are no normative references in this document.

### 3 Terms and definitions

No terms and definitions are listed in this document.

ISO and IEC maintain terminological databases for use in standardization at the following addresses:

- ISO Online browsing platform: available at <https://www.iso.org/obp>
- IEC Electropedia: available at <http://www.electropedia.org/>

### 4 Principle

The prepared flux solution is distilled with sodium hydroxide to expel the ammonia present in the flux. The resulting distillate is passed into a standard sulfuric acid solution. The excess acid is then titrated with sodium hydroxide solution and the ammonia content of the flux is calculated.

### 5 Reagents

Use only reagents of recognized analytical quality, and only distilled or deionized water.

#### 5.1 Sodium hydroxide solution, 1,0 mol/l standard solution, commercially available.

Alternatively, use an approximately 1,0 mol/l solution of sodium hydroxide, prepared by the following method. Dissolve 40 g of sodium hydroxide in water and cool. Transfer the solution to a 1-litre volumetric flask, dilute to the mark and mix well. Standardize this solution with 0,5 mol/l sulfuric acid solution (5.3).

#### 5.2 Sulfuric acid, 0,5 mol/l, standard solution, commercially available.

Alternatively, use an approximately 0,5 mol/l solution of sulfuric acid prepared by the following method. Cautiously add 30 ml of sulfuric acid ( $\rho = 1,84$  g/ml) to 400 ml of water and mix. Cool and transfer to a 1-litre volumetric flask, dilute to the mark and mix well. Standardize this solution with a standard solution prepared from anhydrous sodium carbonate.

NOTE 1 ml of 0,5 mol/l sulfuric acid is equivalent to 0,053 5 g of ammonium chloride.

**5.3 Sulfuric acid**, 50 % (V/V) solution.

Adopting appropriate safety precautions, carefully add 500 ml of sulfuric acid ( $\rho = 1,84$  g/ml) to 500 ml of water. Mix well.

**WARNING — This is a potentially dangerous procedure and should be carried out by a trained person.**

**5.4 Sodium hydroxide solution**, 10 mol/l.

Dissolve 400 g of sodium hydroxide in water. Dilute to 1 l and mix well. This solution should be prepared in a water-cooled polyethylene beaker and stored in a polyethylene bottle.

**5.5 Methyl orange indicator solution**, 0,1 g/100 ml.

Dissolve 0,1 g of methyl orange in 100 ml water. Mix well.

## 6 Apparatus

In addition to ordinary laboratory apparatus, the apparatus shown in [Figure 1](#) is required.

## 7 Procedure

### 7.1 General

Carry out the following procedure in triplicate on the flux sample.

iTeh STANDARD PREVIEW  
(standards.iteh.ai)

### 7.2 Preparation of flux test solution

ISO 9455-9:2020

<https://standards.iteh.ai/catalog/standards/sist/eb9d3108-22c8-482f-80d8-8c69e461f623/iso-9455-9-2020>

#### 7.2.1 Solid fluxes

Weigh 10 g of the solid flux sample into a 400 ml beaker. Add water and sufficient sulfuric acid solution ([5.3](#)) to clear the solution. Transfer to a 500 ml volumetric flask, dilute to the mark and mix.

#### 7.2.2 Paste fluxes

For water-soluble paste fluxes, weigh 10 g of the paste flux sample into a 400 ml beaker. Add water and sufficient sulfuric acid solution ([5.3](#)) to clear the solution. Transfer to a 500 ml volumetric flask, dilute to the mark and mix.

NOTE For non-water-soluble paste fluxes, the method of preparation of the flux test solution can require modification. In such cases, advice can be obtained from the manufacturer.

#### 7.2.3 Liquid fluxes

By means of a pipette, transfer 25 ml of the liquid flux sample to a 500 ml volumetric flask. Dilute to the mark and mix.

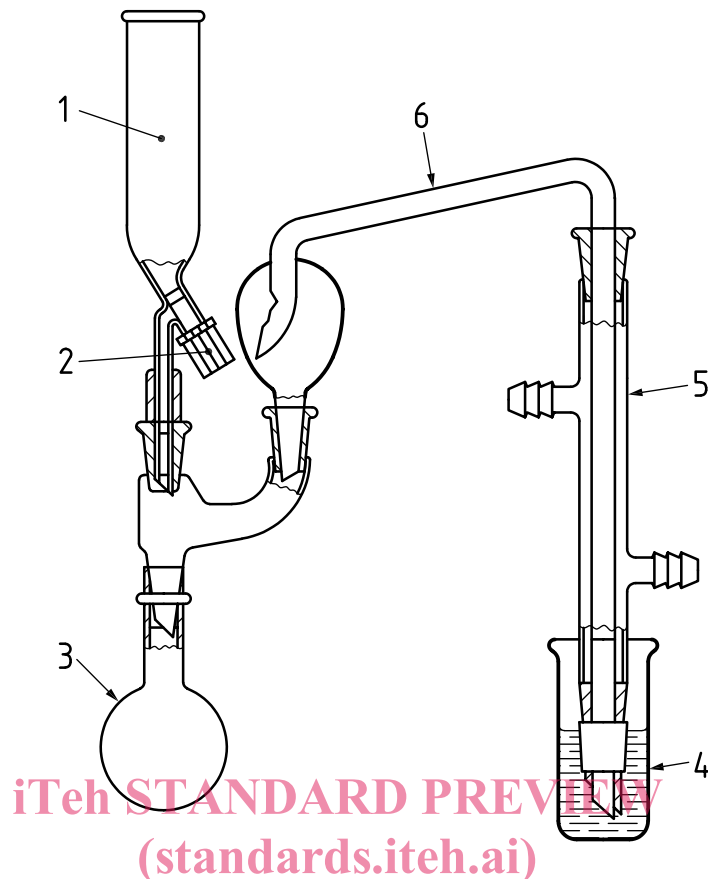
**Key**

- |   |                    |   |                        |
|---|--------------------|---|------------------------|
| 1 | dropping funnel    | 4 | receiver               |
| 2 | tap                | 5 | water-cooled condenser |
| 3 | distillation flask | 6 | splash head            |

**Figure 1 — Apparatus for determination of ammonia content**

### 7.3 Determinations

Set up the apparatus as shown in [Figure 1](#). Ensure that the open end of the water-cooled condenser is well below the level of the solution contained in the receiver.

By means of a pipette or burette, transfer 15,0 ml of the sulfuric acid solution ([5.2](#)) and 100 ml of water to the receiver.

Transfer 100 ml of the flux test solution ([7.1](#)) to the distillation flask. Introduce 30 ml of the 10 mol/l sodium hydroxide solution ([5.4](#)) to the dropping funnel, with the tap closed.

Open the tap of the dropping funnel and run all but approximately 2 ml of the sodium hydroxide solution contained in the funnel into the flask. Heat the contents of the flask to boiling and boil briskly for 10 min, so that the ammonia present in the flux test solution is driven off and collected in the receiver.

**NOTE** This ammonia reacts quantitatively with a proportion of the sulfuric acid contained in the receiver.

Wash the inside of the water-cooled condenser twice with water and add the washings to the receiver.

Titrate the solution in the receiver with 1 mol/l sodium hydroxide solution ([5.1](#)), using methyl orange ([5.5](#)) as indicator.

## 8 Calculation of results

### 8.1 Solid or paste flux samples

The content of ammonia,  $w$ , expressed as a percentage by mass of ammonium chloride, is calculated for solid or paste flux samples, from [Formula \(1\)](#):

$$w = \left[ \frac{(15-V) \times 0,053\ 5 \times 5}{m} \right] \times 100 \quad (1)$$

which can be simplified as [Formula \(2\)](#)

$$w = \frac{26,75(15-V)}{m} \quad (2)$$

where

$V$  is the volume, in millilitres, of sodium hydroxide solution ([5.2](#)) used in the titration;

$m$  is the mass, in grams, of the solid or paste flux sample taken.

### 8.2 Liquid flux samples

The content of ammonia,  $w$ , expressed as a percentage by mass of ammonium chloride, is calculated for liquid flux samples from [Formula \(3\)](#):

$$w = \frac{26,75(15-V)}{25\rho} \quad (3)$$

where  $\rho$  is the density, in g/ml, of the liquid flux sample, at 20 °C, determined with a hydrometer.

## 9 Precision

### 9.1 General

This method was subjected to a limited interlaboratory test programme. The repeatability and reproducibility of the method were calculated in accordance with ISO 5725-1. The results are given in [Table 1](#).

### 9.2 Precision data

Tests were carried out on two zinc chloride fluxes, containing nominal ammonia contents of 2,3 % and 7,0 % respectively. Five laboratories took part in the tests with the following results.

**Table 1 — Results of laboratory tests**

Parameter		Nominal ammonia content of test flux	
		2,3 %	7,0 %
Within laboratory:			
standard deviation	$s_W$	0,04	0,13
repeatability	$r$	0,13	0,36
Between laboratories			
standard deviation	$s_L$	0,11	0,93
reproducibility	$R$	0,30	2,62



## 10 Test report

The test report shall include the following information:

- a) the identification of the test sample;
- b) a reference to this document (i.e. ISO 9455-9:2020);
- c) the results obtained;
- d) any unusual features noted during the determination;
- e) details of any operation not included in this document, or regarded as optional.

**iTeh STANDARD PREVIEW**  
**(standards.iteh.ai)**

ISO 9455-9:2020

<https://standards.iteh.ai/catalog/standards/sist/eb9d3108-22c8-482f-80d8-8c69e461f623/iso-9455-9-2020>