

FINAL  
DRAFT

AMENDMENT

ISO  
3691-3:2016  
FDAM 1

ISO/TC 110/SC 2

Secretariat: SIS

Voting begins on:  
2022-10-13

Voting terminates on:  
2022-12-08

---

---

## Industrial trucks — Safety requirements and verification —

### Part 3: Additional requirements for trucks with elevating operator position and trucks specifically designed to travel with elevated loads

#### AMENDMENT 1

*Chariots de manutention — Exigences de sécurité et vérification —*

*Partie 3: Exigences complémentaires pour chariots avec poste de conduite élevable et pour chariots spécialement conçus pour une conduite avec des charges en élévation*

AMENDEMENT 1

ISO/CEN PARALLEL PROCESSING

RECIPIENTS OF THIS DRAFT ARE INVITED TO SUBMIT, WITH THEIR COMMENTS, NOTIFICATION OF ANY RELEVANT PATENT RIGHTS OF WHICH THEY ARE AWARE AND TO PROVIDE SUPPORTING DOCUMENTATION.

IN ADDITION TO THEIR EVALUATION AS BEING ACCEPTABLE FOR INDUSTRIAL, TECHNOLOGICAL, COMMERCIAL AND USER PURPOSES, DRAFT INTERNATIONAL STANDARDS MAY ON OCCASION HAVE TO BE CONSIDERED IN THE LIGHT OF THEIR POTENTIAL TO BECOME STANDARDS TO WHICH REFERENCE MAY BE MADE IN NATIONAL REGULATIONS.



Reference number  
ISO 3691-3:2016/FDAM 1:2022(E)

© ISO 2022

iTeh STANDARD PREVIEW  
(standards.iteh.ai)

ISO 3691-3:2016/Amd 1

<https://standards.iteh.ai/catalog/standards/sist/27e978d8-f87a-4303-b786-8e899fb6ab2d/iso-3691-3-2016-amd-1>



**COPYRIGHT PROTECTED DOCUMENT**

© ISO 2022

All rights reserved. Unless otherwise specified, or required in the context of its implementation, no part of this publication may be reproduced or utilized otherwise in any form or by any means, electronic or mechanical, including photocopying, or posting on the internet or an intranet, without prior written permission. Permission can be requested from either ISO at the address below or ISO's member body in the country of the requester.

ISO copyright office  
CP 401 • Ch. de Blandonnet 8  
CH-1214 Vernier, Geneva  
Phone: +41 22 749 01 11  
Email: [copyright@iso.org](mailto:copyright@iso.org)  
Website: [www.iso.org](http://www.iso.org)

Published in Switzerland

## Foreword

ISO (the International Organization for Standardization) is a worldwide federation of national standards bodies (ISO member bodies). The work of preparing International Standards is normally carried out through ISO technical committees. Each member body interested in a subject for which a technical committee has been established has the right to be represented on that committee. International organizations, governmental and non-governmental, in liaison with ISO, also take part in the work. ISO collaborates closely with the International Electrotechnical Commission (IEC) on all matters of electrotechnical standardization.

The procedures used to develop this document and those intended for its further maintenance are described in the ISO/IEC Directives, Part 1. In particular, the different approval criteria needed for the different types of ISO documents should be noted. This document was drafted in accordance with the editorial rules of the ISO/IEC Directives, Part 2 (see [www.iso.org/directives](http://www.iso.org/directives)).

Attention is drawn to the possibility that some of the elements of this document may be the subject of patent rights. ISO shall not be held responsible for identifying any or all such patent rights. Details of any patent rights identified during the development of the document will be in the Introduction and/or on the ISO list of patent declarations received (see [www.iso.org/patents](http://www.iso.org/patents)).

Any trade name used in this document is information given for the convenience of users and does not constitute an endorsement.

For an explanation of the voluntary nature of standards, the meaning of ISO specific terms and expressions related to conformity assessment, as well as information about ISO's adherence to the World Trade Organization (WTO) principles in the Technical Barriers to Trade (TBT), see [www.iso.org/iso/foreword.html](http://www.iso.org/iso/foreword.html).

This document was prepared by Technical Committee ISO/TC 110, *Industrial trucks*, Subcommittee SC 2, *Safety of powered industrial trucks*, in collaboration with the European Committee for Standardization (CEN) Technical Committee CEN/TC 150, *Industrial Trucks - Safety*, in accordance with the Agreement on technical cooperation between ISO and CEN (Vienna Agreement).

A list of all parts in the ISO 3691 series can be found on the ISO website.

Any feedback or questions on this document should be directed to the user's national standards body. A complete listing of these bodies can be found at [www.iso.org/members.html](http://www.iso.org/members.html).



# Industrial trucks — Safety requirements and verification —

Part 3:

## Additional requirements for trucks with elevating operator position and trucks specifically designed to travel with elevated loads

### AMENDMENT 1

#### *Scope*

Replace reference to “ISO/TS 3691-7” with reference to “EN 16307-3”.

#### *Normative references*

Replace “ISO 6292:2008” with “ISO 6292:2020” and “ISO 5053-1:2015” with “ISO 5053-1:2020”.

#### *Clause 3*

Replace term entry 3.2 with the following:

#### **3.2**

##### **elevating operator position**

normal operating position on the operator’s platform as defined by the manufacturer which can be elevated more than 1 200 mm from the ground to the floor of the platform measured with the truck unladen

Note 1 to entry Area where the operator is positioned (standing or sitting) for operating the truck, e.g. travel, lift/lower.

Replace the preferred term in term entry 3.8 with the following:

##### **fall protection system**

Add the following new term entry at the end of Clause 3:

#### **3.11**

##### **defined walking surface**

load-carrying surface for the operator to temporarily step on (e.g. pallet) to facilitate efficient handling of load

4.3.1

Replace the whole subclause with the following:

For operations without guidance systems, the braking performance shall conform to ISO 6292:2020, Table 2 or 3, group C.

Braking when travelling at more than 9 km/h can be subject to regional requirements, additional to the requirements of this document. See EN 16307-3.

4.4.5.1

Replace the first paragraph with the following:

Elevated operator's platforms with a lift height of more than 1 200 mm from the ground and fixed operator's stand-on platforms located at heights of more than 1 200 mm shall be equipped with mechanical guards on all sides (e.g. guard rails, access gates).

Replace the second sentence in the second paragraph with the following:

The means shall be capable of withstanding without permanent deformation a force of 900 N applied in a vertical downwards direction and a force of 900 N applied in a horizontal direction from the inside to the outside, at their location(s) of least strength, and shall not be capable of being opened outwards.

Replace reference "ISO/TS 3691-7" with reference "EN 16307-3".

Replace Figure 3 with the following Figure 3 a) and 3 b):

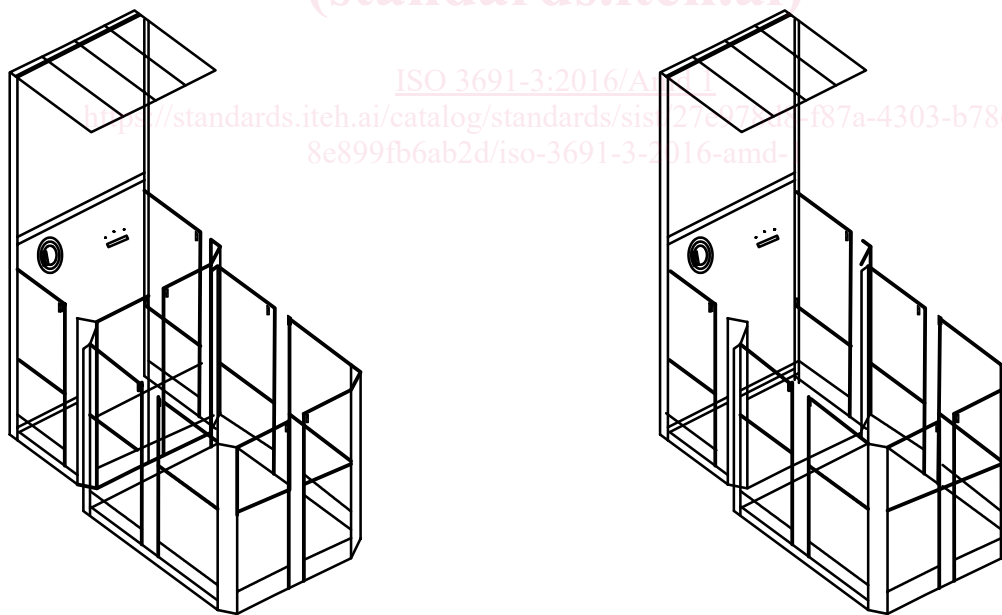

**a) Without supplementary platform interlock      b) With supplementary platform interlock**

**Figure 3 — Supplementary platform (schematic only)**

Replace Figure 4 with the following Figure 4 a) and 4 b):

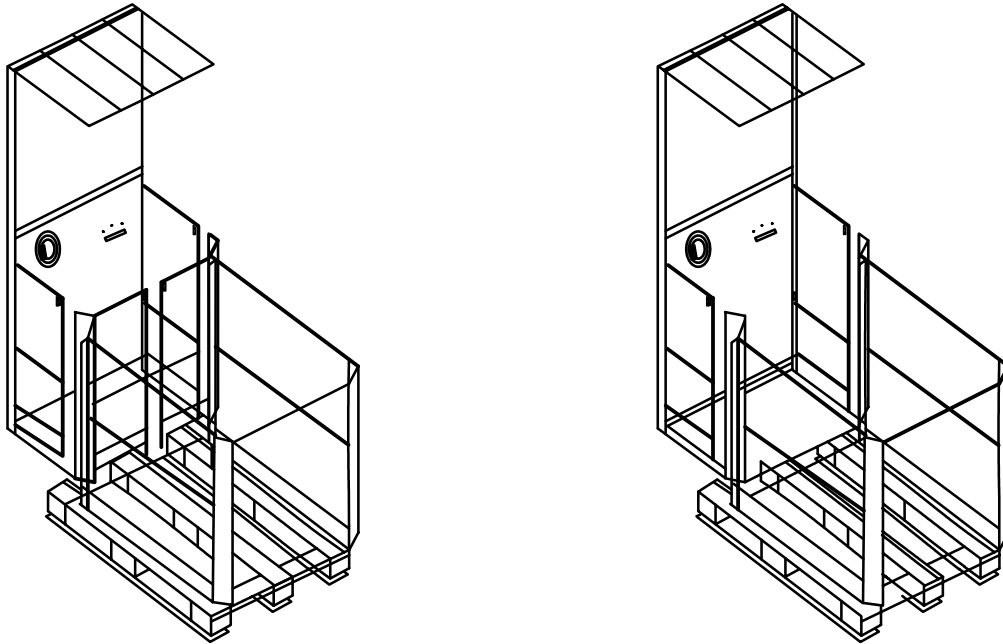

a) Without supplementary platform interlock

b) With pallet interlock

**Figure 4 — Supplementary platform with defined walking surface (pallet) (schematic only)**

#### 4.4.5.2

Replace the second paragraph with:

Interlocking gates are not required if a personal fall protection system according to 4.4.5.5 is used.

#### 4.4.5.3

Replace the first paragraph with:

The whole surface accessible to personnel shall be protected against falling according to 4.4.5.1. If an extended or an interlocked supplementary platform as shown in Figures 2 and 3 b) is provided, it shall fulfil the requirements of 4.4.5.1 and 4.4.5.2 and shall be extended to encompass the whole area accessible to the operator and assistant if an assistant is permitted by design. Where a supplementary platform interlock is fitted, and the platform [see Figure 3 b)] is not detected, elevating shall be disabled above 1 200 mm.

If no supplementary platform is in place, a mechanical guard as specified in 4.4.5.1 and 4.4.5.2 shall be in place between the operator's platform and the load-handling device (see Figure 1).

If the supplementary platform is in place but not interlocked, a fall protection as specified in 4.4.5.1 and 4.4.5.2 shall be in place between the operator's platform and the supplementary platform [see Figure 3 a)].

Supplementary platforms shall have elevating, lowering and travel disabled when any gate is opened and the height reaches, or is greater than, 1 200 mm.

In the last paragraph, replace "fall protection device" with "personal fall protection system".

In the last paragraph, replace "ISO/TS 3691-7" with "EN 16307-3".

#### 4.4.5.4

Replace the whole subclause with the following:

For trucks intended by the manufacturer to be used with an interlocked defined walking surface, as shown in Figure 4 b), means, which are part of the truck, shall be provided to join the walking surface by a positive engagement device to prevent overturning and shifting of that walking surface [see 6.2 f)]. Disposable pallets are not allowed. Where a defined walking surface interlock is fitted, and the defined walking surface [see Figure 4 b)] is not detected, elevating shall be disabled above 1 200 mm.

If no defined walking surface is in place, a mechanical guard as specified in 4.4.5.1 and 4.4.5.2 shall be in place between the operator platform and the load-handling device (Figure 1)

If the defined walking surface is in place but not interlocked, a mechanical guard as specified in 4.4.5.1 and 4.4.5.2 shall be in place between the operator's platform and the defined walking surface [Figure 4 a)].

Defined walking surfaces shall have elevating, lowering and travel disabled when any gate is opened and the height reaches, or is greater than, 1 200 mm.

A top rail omitting the intermediate rail and the toe board at the opposite end of the supplementary platform from the operator's platform meets the guarding requirements. If the top rail is capable of being opened or removed, then it shall be interlocked in accordance with 4.4.5.2.

NOTE This enables the truck to pull away when the pallet is loaded or to engage a new pallet.

iTeh STANDARD PREVIEW  
(standards.iteh.ai)

#### 4.4.5.5

Replace the whole subclause with the following:

Platforms equipped with a personal fall protection system can be subject to regional requirements, additional to the requirements of this document. See EN16307-3 and ISO/TS 3691-8.

#### 4.6

Delete the sentence:

“The requirements for stability are subject to regional requirements; see ISO/TS 3691-7.”

#### Bibliography

Delete:

[1] ISO/TS 3691-7, *Industrial trucks — Safety requirements and verification — Part 7: Regional requirements for countries within the European Community*

Add:

[1] EN 16307-3<sup>1)</sup>, *Industrial trucks - Safety requirements and verification - Part 3 Supplementary requirements for trucks with elevating operator position and trucks specifically designed to travel with elevated loads (additional requirements to EN 16307-1)*

---

1) Under preparation.





iTeh STANDARD PREVIEW  
(standards.iteh.ai)

ISO 3691-3:2016/Amd 1

<https://standards.iteh.ai/catalog/standards/sist/27e978d8-f87a-4303-b786-8e899fb6ab2d/iso-3691-3-2016-amd-1>