



Designation: D4446 – 08(Reapproved 2012)

Standard Test Method for Anti-Swelling Effectiveness of Water-Repellent Formulations and Differential Swelling of Untreated Wood When Exposed to Liquid Water Environments¹

This standard is issued under the fixed designation D4446; the number immediately following the designation indicates the year of original adoption or, in the case of revision, the year of last revision. A number in parentheses indicates the year of last reapproval. A superscript epsilon (ϵ) indicates an editorial change since the last revision or reapproval.

1. Scope

1.1 This test method is designed to evaluate the effectiveness of water-repellent compositions for retarding dimensional changes in coated wood submerged in water. It can also be used to measure the differential swelling of untreated wood when exposed to liquid water environments. The compositions tested are designed to be mixed until uniform and applied by brush, roller, dip or spray to an exterior wood surface.

1.2 The values stated in SI units are to be regarded as the standard. The values given in parentheses are for information only.

1.3 *This standard does not purport to address all of the safety concerns, if any, associated with its use. It is the responsibility of the user of this standard to establish appropriate safety and health practices and determine the applicability of regulatory limitations prior to use.*

2. Summary of Method

2.1 Wood samples in the form of elongated slats that represent the timber species or product/treatment combination to be evaluated are exposed in soak containers. The elongated slats are immersed in the water-repellent formulation, conditioned with appropriate weighing, then subjected to immersion in distilled water for a prescribed period. The untreated slats omit the immersion in the water-repellent formulation. The swelling resulting from immersion for the selected time period is determined by reading a dial gage calibrated in increments of 0.025 mm (0.001 in.).

2.2 A water repellent efficiency of 60 % is required to pass this test.

3. Significance and Use

3.1 This test method is useful in determining the relative anti-swelling efficiency of various water-repellent formulations

when applied to wood. It is the initial means of estimating the ability of water-repellent treated wood to perform satisfactorily when exposed to liquid water environments.

3.2 The swelling differences of untreated wood species when subjected to water immersion can also be determined by this test method.

3.3 This method is a basic screening test and thus provides an initial determination of the anti-swelling efficiency of water repellents. It is a qualitative method designed to provide a reproducible means of establishing: (1) the anti-swelling efficiency of water-repellent formulations, and (2) the relative swelling of untreated wood species when both are exposed to liquid water environments.

4. Apparatus

4.1 *Conditioning Room or Chamber*, having a controlled temperature of $23 \pm 2^\circ\text{C}$ ($73.5 \pm 3.5^\circ\text{F}$), and a controlled relative humidity of $50 \pm 5\%$. This room is used to establish a uniform moisture content in the test specimens. *In all studies the temperature and relative humidity selected by the investigator must be stated and must remain constant throughout a given conditioning and test period.*

4.2 *Balance*, sensitive to at least 0.01 g.

4.3 *Treating Tank* (Fig. 1).

4.4 *Swellometer*, as illustrated in Fig. 2, Fig. 3, and Fig. 4.

5. Test Specimens

5.1 Wood used for these tests must be straight-grained, flat-sawn, clear, kiln-dried Ponderosa pine sapwood or other suitable species. Cut the parent boards in a manner to give specimens 6 mm ($\frac{1}{4}$ in.) in the longitudinal dimension, 1½ in. (38 mm) in the radial dimension, and 254 mm (10 in.) in the tangential dimension. Cut with a sharp, fine-toothed saw to obtain as smooth a surface as possible without sanding. Number each specimen for identification and reference.

5.1.1 Selection of Ponderosa pine sapwood can be assured by the following quick chemical test: (1) prepare a solution of 5 g of benzidine in 25 g of hydrochloric acid and 970 g of water, and (2) prepare a second solution consisting of a 10 % concentration of sodium nitrite in water. When the test is to be

¹ This test method is under the jurisdiction of ASTM Committee D01 on Paint and Related Coatings, Materials, and Applications and is the direct responsibility of Subcommittee D01.42 on Architectural Coatings.

Current edition approved July 1, 2012. Published August 2012. Originally approved in 1995. Last previous edition approved in 2008 as D4446 – 08. DOI: 10.1520/D4446-08R12.

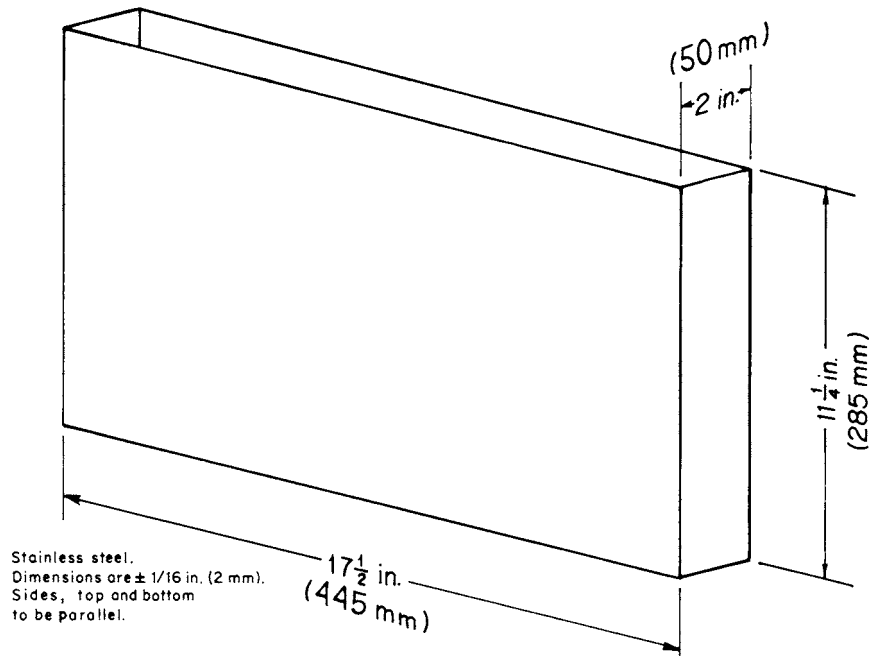

FIG. 1 Treating Tank—Five Samples Tested Simultaneously

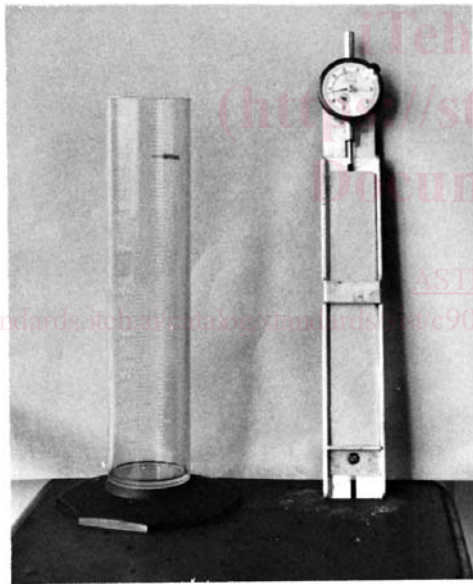

FIG. 2 Single Test Swellometer Tank and One Sample



FIG. 3 Single Test Swellometer Tank—With One Sample In Place

made, pour equal amounts of the two solutions together and then apply to the wood surface by means of brushing or dipping. The sapwood immediately shows a yellowish color, while the heartwood turns dark red-brown. The colors remain distinct after drying.

5.2 Determine the swelling of an untreated specimen from each parent board before testing begins. Do this by equilibrating the specimen in accordance with 7.1 and then testing in accordance with 7.5.1. The swelling shall not be less than 8.25 mm (0.325 in.). See Table 1.

6. Formulations

6.1 Treat the test specimens with the ready-to-use formulation as advocated by the manufacturer of the formulation.

6.2 Test, experimental or control formulations may be added to the test as desired.

6.3 Establish adequate records, reference samples and identification to permit independent review and analysis.

7. Test Procedure

7.1 Cut two adjacent specimens, both either tangentially or longitudinally, from each board. Specimen pairs from ten