



# Standard Test Method for Water Resistance of Footwear Using a Walking Step Simulator<sup>1</sup>

This standard is issued under the fixed designation F1900; the number immediately following the designation indicates the year of original adoption or, in the case of revision, the year of last revision. A number in parentheses indicates the year of last reapproval. A superscript epsilon ( $\epsilon$ ) indicates an editorial change since the last revision or reapproval.

## 1. Scope

1.1 This test method covers a method of measuring the water resistance of footwear.

1.2 *This standard does not purport to address all of the safety concerns, if any, associated with its use. It is the responsibility of the user of this standard to establish appropriate safety and health practices and determine the applicability of regulatory limitations prior to use.*

## 2. Referenced Documents

### 2.1 ASTM Standards:<sup>2</sup>

D2098 Test Method for Dynamic Water Resistance of Shoe Upper Leather by the Dow Corning Leather Tester

D2099 Test Method for Dynamic Water Resistance of Shoe Upper Leather by the Maeser Water Penetration Tester

### 2.2 SATRA Test Method:<sup>3</sup>

Physical Test Method PM81 Trough-Water Penetration Test

### 2.3 FIA Test Methods:<sup>4</sup>

No. 1209, Appendix B—Whole Shoe Flex in Water

## 3. Significance and Use

3.1 Water resistance is a desirable characteristic for many different types of footwear. This test method provides a guide for measuring water resistance under dynamic conditions that closely duplicate normal human walking. The degree of correlation between this test and footwear performance in the field or footwear performance in the SATRA Trough-Water Penetration Test has not been fully determined.

<sup>1</sup> This test method is under the jurisdiction of ASTM Committee F08 on Sports Equipment and Facilities and is the direct responsibility of Subcommittee F08.54 on Athletic Footwear.

Current edition approved May 15, 2012. Published August 2012. Originally approved in 1998. Last previous edition approved in 2004 as F1900 – 98 (2004). DOI: 10.1520/F1900-98R12.

<sup>2</sup> For referenced ASTM standards, visit the ASTM website, www.astm.org, or contact ASTM Customer Service at service@astm.org. For *Annual Book of ASTM Standards* volume information, refer to the standard's Document Summary page on the ASTM website.

<sup>3</sup> Available from SATRA Footwear Technology Centre, Rockingham Road, Kettering, Northamptonshire, NN16 9JH, United Kingdom.

<sup>4</sup> Available from Footwear Industries of America, 1420 K St. NW, Suite 600, Washington, DC.

## 4. Apparatus

4.1 *Mechanism*, such as the one shown in Fig. 1, that approximates the movements and forces involved in human walking motion. The important features of the walking motion produced by the mechanism are defined as follows:

4.1.1 At the beginning of a step (the point where the heel of the footwear touches the walking surface) the leg pylon attached to the prosthetic foot shall form an angle of  $16 \pm 5^\circ$  (relative to a line perpendicular to the walking surface) as shown in Fig. 2.

4.1.2 At the end of a step (the point where the toe of the footwear departs from the walking surface) the leg pylon shall form an angle  $31 \pm 5^\circ$  (see Fig. 2).

4.1.3 Each step shall begin with no force being exerted on the footwear and with the footwear not in contact with the walking surface. When the footwear contacts the walking surface, it shall remain in contact during the entire support phase of the step and then depart from the walking surface at the end of the step.

4.1.4 During the support phase of each step, a downward force shall be applied to the footwear to simulate the weight of the user. The force shall equal one bodyweight of the typical prospective user, with a tolerance of  $\pm 10\%$ , unless a different force is specified. Table 1 lists the body masses of 50th percentile adults and children, and the equivalent one bodyweight downward force levels. If no other downward force is specified, the values in Table 1 shall be used.

NOTE 1—The force under the prosthetic foot can be measured with a load cell or force plate.

4.2 *Men's 26-cm (U.S. Size 9) or Women's 24-cm (U.S. Size 7) Right or Left Prosthetic Foot*, shall be used unless a different size is specified. The foot shall closely approximate the shape, texture, and flexibility of a human foot.

4.2.1 A minimum of six moisture sensors shall be placed at the following locations on the prosthetic foot: instep, big toe, inner and outer ball, and inner and outer heel, as illustrated in Fig. 3.

4.2.2 The moisture sensors shall determine the presence of water. A circuit diagram for a sensor that has proven to be suitable for this application is shown in Fig. 4.

4.3 *Water Tank*, made of stainless steel (or other corrosion-resistant material). The tank shall be large enough so that the

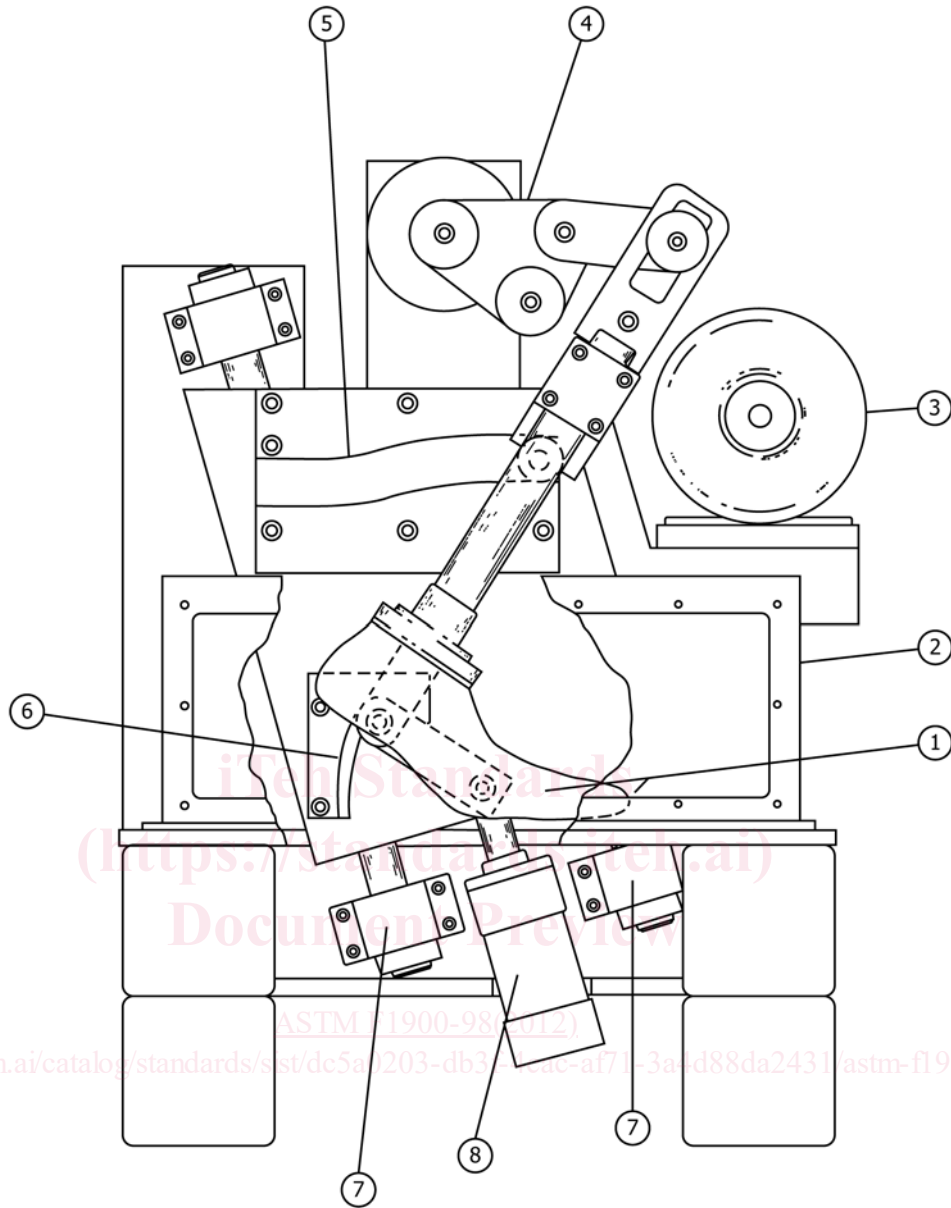

- (1) Prosthetic foot with moisture sensors
- (2) Water tank
- (3) Motor with speed control
- (4) Mechanism for producing back and forth motion
- (5) Cam to control location of knee
- (6) Cam to control location of ankle
- (7) Slide mechanism
- (8) Air cylinder to lower the foot at the beginning of each step and raise it again at the completion of each step

**FIG. 1 Footwear Tester**

upper portion of a shoe or boot does not come in contact with the tank at any time during the test. The tank should have an opening in the front, that is covered by transparent material, to permit observation of the footwear during the test.

4.4 *Recording Device*, that counts the number of steps (cycles) that the footwear is subjected to, monitors the moisture

sensors, and records the number of steps that have been accomplished when the sensors become “wet.”

## 5. Reagents

5.1 *Tap Water*, 20 to 25°C.