**Textiles — Evaluation of the wrinkle
recovery of fabrics — Appearance
method**

*Textiles — Évaluation de la défroissabilité des étoffes — Méthode
d'évaluation de l'aspect*

iTeh STANDARD PREVIEW
(standards.iteh.ai)

ISO 9867:2022

<https://standards.iteh.ai/catalog/standards/sist/366bd0ff-cdfb-491e-b985-13b0e5bde115/iso-9867-2022>



iTeh STANDARD PREVIEW
(standards.iteh.ai)

ISO 9867:2022

<https://standards.iteh.ai/catalog/standards/sist/366bd0ff-cdfb-491e-b985-13b0e5bde115/iso-9867-2022>



COPYRIGHT PROTECTED DOCUMENT

© ISO 2022

All rights reserved. Unless otherwise specified, or required in the context of its implementation, no part of this publication may be reproduced or utilized otherwise in any form or by any means, electronic or mechanical, including photocopying, or posting on the internet or an intranet, without prior written permission. Permission can be requested from either ISO at the address below or ISO's member body in the country of the requester.

ISO copyright office
CP 401 • Ch. de Blandonnet 8
CH-1214 Vernier, Geneva
Phone: +41 22 749 01 11
Email: copyright@iso.org
Website: www.iso.org

Published in Switzerland

Contents

	Page
Foreword.....	iv
1 Scope.....	1
2 Normative references.....	1
3 Terms and definitions.....	1
4 Principle.....	1
5 Apparatus and materials.....	1
6 Atmospheres for conditioning, testing and evaluation.....	4
7 Test specimens.....	4
7.1 Preparation.....	4
7.2 Conditioning.....	4
8 Procedure.....	4
9 Evaluation.....	5
10 Expression of results.....	6
11 Test report.....	6
Annex A (informative) Digital description of the ISO wrinkle replicas.....	7
Bibliography.....	21

iTeh STANDARD PREVIEW
(standards.iteh.ai)

ISO 9867:2022

<https://standards.iteh.ai/catalog/standards/sist/366bd0ff-cdfb-491e-b985-13b0e5bde115/iso-9867-2022>

Foreword

ISO (the International Organization for Standardization) is a worldwide federation of national standards bodies (ISO member bodies). The work of preparing International Standards is normally carried out through ISO technical committees. Each member body interested in a subject for which a technical committee has been established has the right to be represented on that committee. International organizations, governmental and non-governmental, in liaison with ISO, also take part in the work. ISO collaborates closely with the International Electrotechnical Commission (IEC) on all matters of electrotechnical standardization.

The procedures used to develop this document and those intended for its further maintenance are described in the ISO/IEC Directives, Part 1. In particular, the different approval criteria needed for the different types of ISO documents should be noted. This document was drafted in accordance with the editorial rules of the ISO/IEC Directives, Part 2 (see www.iso.org/directives).

Attention is drawn to the possibility that some of the elements of this document may be the subject of patent rights. ISO shall not be held responsible for identifying any or all such patent rights. Details of any patent rights identified during the development of the document will be in the Introduction and/or on the ISO list of patent declarations received (see www.iso.org/patents).

Any trade name used in this document is information given for the convenience of users and does not constitute an endorsement.

For an explanation of the voluntary nature of standards, the meaning of ISO specific terms and expressions related to conformity assessment, as well as information about ISO's adherence to the World Trade Organization (WTO) principles in the Technical Barriers to Trade (TBT), see www.iso.org/iso/foreword.html.

This document was prepared by Technical Committee ISO/TC 38, *Textiles*, Subcommittee SC 2, *Cleansing, finishing and water resistance tests*.

This third edition cancels and replaces the second edition (ISO 9867:2009), which has been technically revised.

The main changes are as follows:

- [Clause 3](#), Terms and definitions, has been added and subsequent clauses have been renumbered;
- requirements for “Wrinkle tester” has been added in [5.1](#) (former 4.1);
- [Figure 1](#) has been improved;
- a “timer” has been added in the list of apparatus in [Clause 5](#) (former Clause 4);
- the requirements of atmospheres for preconditioning, conditioning and testing have been revised;
- addition of “If the rating appears between two ratings, intermediate rating can be used in increments of a half for a rating (for example, No. 3,5).” in [9.4](#) (Former [8.4](#));
- the description of wrinkle rating has been added in [Table 1](#);
- the annex on the “Summary of an international interlaboratory study on wrinkle recovery of fabrics” has been deleted and the former Annex B has been relabelled as Annex A.

Any feedback or questions on this document should be directed to the user's national standards body. A complete listing of these bodies can be found at www.iso.org/members.html.

Textiles — Evaluation of the wrinkle recovery of fabrics — Appearance method

1 Scope

This document specifies a method for evaluating the appearance of textile fabrics after induced wrinkling.

This document is applicable to all kinds of textile fabrics.

NOTE A digital description of the ISO wrinkle replicas is given in [Annex A](#).

2 Normative references

The following documents are referred to in the text in such a way that some or all of their content constitutes requirements of this document. For dated references, only the edition cited applies. For undated references, the latest edition of the referenced document (including any amendments) applies.

ISO 105-A03, *Textiles — Tests for colour fastness — Part A03: Grey scale for assessing staining*

ISO 139, *Textiles — Standard atmospheres for conditioning and testing*

3 Terms and definitions

For the purposes of this document, the following terms and definitions apply.

ISO and IEC maintain terminological databases for use in standardization at the following addresses:

- ISO Online browsing platform: available at <https://www.iso.org/obp>
- IEC Electropedia: available at <https://www.electropedia.org/>

3.1

wrinkle recovery

property of a fabric which enables it to recover from wrinkling deformations

4 Principle

A test specimen is wrinkled under a specified atmospheric condition in a wrinkling device under a pre-determined load for a prescribed period of time. After reconditioned, the test specimen is evaluated for appearance by comparison with three-dimensional wrinkle recovery replicas or wrinkle rating description.

5 Apparatus and materials

5.1 **Wrinkle tester** (see [Figure 1](#)), consisting of the following parts:

- a) a circular top flange and a circular bottom flange, with the diameter of $(89,0 \pm 0,5)$ mm, and the distance of (110 ± 1) mm between the initial position of the top flange and the bottom flange to ensure that the top flange can rotate $(180 \pm 1)^\circ$ while moving down to the bottom. The mass of the top flange is approximately 500 g;
- b) a weight-piece, with a mass of 3 500 g;

- c) specimen clamps, for holding the test specimen;
- d) locking pin, for fixing the top flange in the initial position.

NOTE Equivalent devices can be used if they can be shown to lead to the same results.

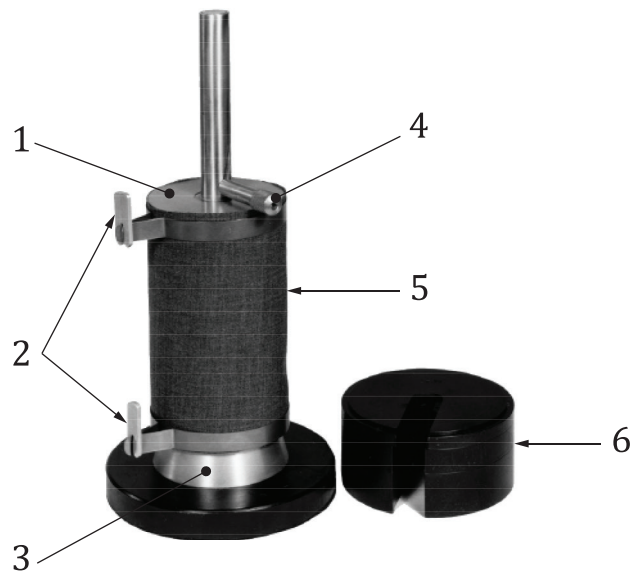

Key

- 1 top flange
- 2 specimen clamps
- 3 bottom flange
- 4 locking pin
- 5 test specimen
- 6 weight-piece

iTeh STANDARD PREVIEW
(standards.iteh.ai)

ISO 9867:2022

<https://standards.iteh.ai/catalog/standards/sist/366bd0ff-cdfb-491e-b985-13b0e5bde115/iso-9867-2022>

Figure 1 — Wrinkle tester

5.2 Three-dimensional wrinkle recovery replicas (see [Figure 2](#)).

5.3 Lighting and evaluation area, in a darkened room, using the overhead lighting arrangement illustrated in [Figure 3](#) and comprising the items described in the following list. The lamp dimensions should be chosen to extend beyond the overall surface of the test specimen and replicas, when used for the assessment.

- a) **Two cool white (CW) fluorescent lamps**, without a baffle or glass, a minimum of 2 m in length each, placed side by side.
- b) **One white enamel reflector**, without a baffle or glass.
- c) **One thick plywood viewing board**, painted grey to match the Grade 2 on the grey scale for assessing staining in accordance with ISO 105-A03.

5.4 Clothes hangers with clips, to hang test specimens for conditioning and grading.

5.5 **Timer**, with an accuracy of 0,2 s.

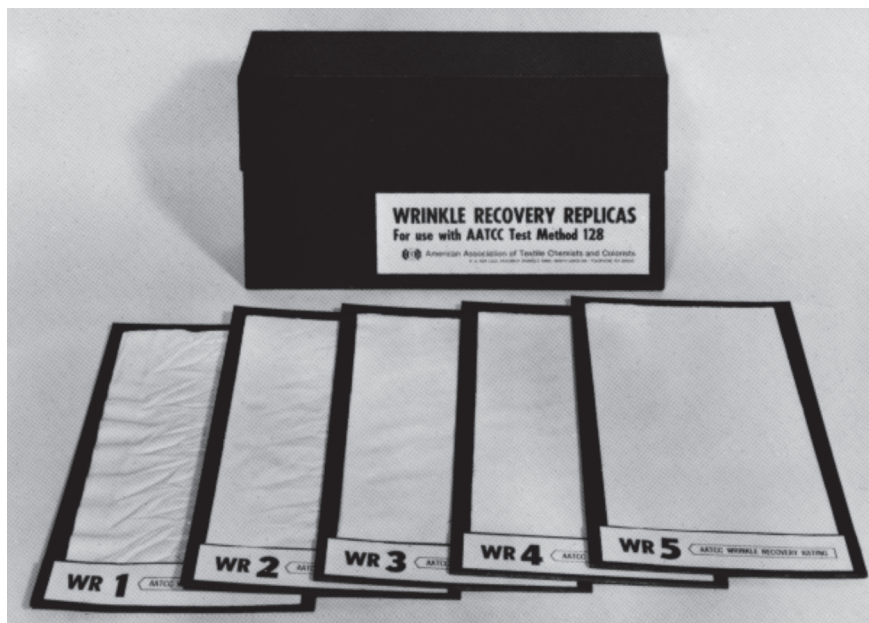
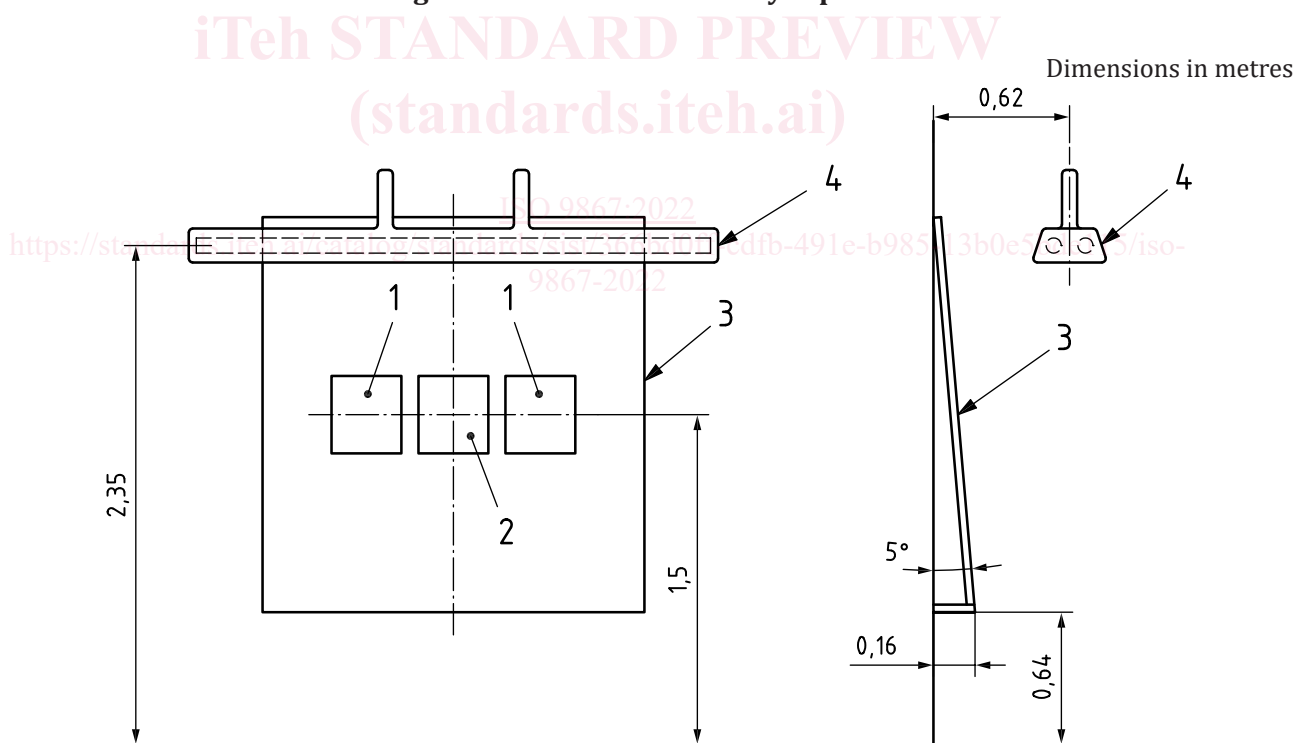

Figure 2 — Wrinkle recovery replicas



Key

- 1 replica
- 2 test specimen
- 3 board for viewing
- 4 example of fluorescent lamp placement

Figure 3 — Lighting equipment for viewing test specimens

6 Atmospheres for conditioning, testing and evaluation

The atmospheres for preconditioning, conditioning, testing and evaluation shall be as specified in ISO 139.

7 Test specimens

7.1 Preparation

The test specimens shall be taken not less than 150 mm from the fabric selvedge. No test specimens are taken from the same longitudinal or transverse direction.

Cut three test specimens from the fabric to be tested, each measuring 150 mm × 280 mm, and each with the long dimension parallel to the warp direction (woven fabric), or the wale direction (knitted fabric), or the direction marked “length” (nonwoven fabric). Identify each specimen along one edge of the face side.

Cut the test specimens from an area of the fabric that is free from wrinkles. If any wrinkles are unavoidably present in the test specimens, press each test specimen lightly with a steam iron before conditioning.

7.2 Conditioning

Precondition and then condition the test specimens in accordance with ISO 139.

8 Procedure

8.1 Raise the top flange of the wrinkle tester (5.1) and hold it in the top position with the locking pin.

8.2 Wrap one long edge (i.e. the 280 mm side) of a preconditioned and conditioned test specimen (see 7.2) around the top flange of the wrinkle tester, with the face side of the test specimen on the outside, and clamp it in position using the steel spring and clamp provided. Arrange the ends of the test specimen so that they are opposite the opening in the spring clamp.

8.3 Wrap the opposite long edge of the test specimen around the bottom flange and clamp it as described in 8.2.

8.4 Adjust the test specimen by pulling on its bottom edge so that it lies smooth without sagging between the top and bottom flanges.

8.5 Withdraw the locking pin. The top flange is lowered gently to the bottom flange while horizontally rotating $(180 \pm 1)^\circ$.

8.6 Immediately place a weight-piece with the mass of 3 500 g on the top flange and record the time.

There can be differences in the weights supplied with different wrinkle testers. If necessary, add additional weights to the top flange to achieve a total mass of 3 500 g on the top flange.

8.7 After $(20,0 \pm 0,1)$ min, remove the weight-piece, the springs and the clamps. Raise the top flange and gently remove the test specimen from the wrinkle tester so as not to distort any induced wrinkles.

8.8 With a minimum of handling, place the shorter edge (i.e. the 150 mm side) under the clips on the clothes hanger (5.4) and allow the test specimen to hang vertically in the long direction.

8.9 After 24 h in the standard atmosphere (see [Clause 6](#)), gently remove the hanger with the specimen and transfer it to the evaluation area ([5.3](#)).

9 Evaluation

9.1 Three trained observers shall rate each test specimen independently.

Since previous tests have proven that specimens change in appearance during the first few hours, it is important that accurate times be observed and that a minimum time elapse while the three observers are evaluating the specimens. Because of these changing conditions, the duration of recovery before rating for this method has been standardized at 24 h.

9.2 Mount the test specimen on the viewing board [[5.3 c](#)] as illustrated in [Figure 3](#), with the warp, wale or marked “length” direction vertical. Place three-dimensional wrinkle recovery replicas ([5.2](#)), one on each side of the test specimen, to facilitate comparative rating. Mount replicas 1, 3 or 5 on the left side and 2 or 4 on the right side.

The overhead fluorescent light shall be the only light source for the viewing board, and all other lights in the room shall be turned off.

It has been the experience of many observers that light reflected from the side walls near the viewing board can interfere with the rating results. It is recommended that the side walls be painted black, or that blackout curtains be mounted on either side of the viewing board, to eliminate reflective interference.

9.3 The observer shall stand directly in front of the specimen, 1,20 m away from the bottom front of the board.

NOTE It has been found that normal variations in the height of the observer above and below the arbitrary 1,50 m eye level have no significant effect on the rating given.

9.4 Assign the number of the replica which most closely matches the appearance of the test specimen (see [Table 1](#)). If the rating appears between two ratings, intermediate rating can be used in increments of a half for a rating (for example, No. 3,5).

NOTE A No. 5 rating is equivalent to the WR-5 replica and represents the smoothest appearance and best retention of the original appearance. A No. 1 rating is equivalent to the WR-1 replica and represents the poorest appearance and poorest retention of the original appearance.

9.5 Similarly, the observer independently rates the other two test specimens. The other two observers proceed in the same manner, assigning ratings independently.

Table 1 — Fabric smoothness ratings

Rating No.	Fabric appearance
5	no change, equivalent to the WR-5 replica
4	slight wrinkles, equivalent to the WR-4 replica
3	clear wrinkles with no distinct wave, equivalent to the WR-3 replica
2	obvious wrinkles with distinct wave covering a large proportion of specimen surface, equivalent to the WR-2 replica
1	severe wrinkles with distinct wave covering the whole specimen surface, equivalent to or worse than the WR-1 replica

10 Expression of results

Calculate the average of the nine observations for each sample and express the results to the nearest half-rating.

11 Test report

The test report shall include the following information:

- a) a reference to this document, i.e. ISO 9867:2022;
- b) all details necessary for the identification of the sample tested;
- c) the average of the nine observations made for each sample, to the nearest half-rating;
- d) the conditioning atmosphere used for testing;
- e) details of any deviation from the specified procedure;
- f) date of the test.

iTeh STANDARD PREVIEW
(standards.iteh.ai)

ISO 9867:2022

<https://standards.iteh.ai/catalog/standards/sist/366bd0ff-cdfb-491e-b985-13b0e5bde115/iso-9867-2022>

Annex A (informative)

Digital description of the ISO wrinkle replicas

A.1 General

This annex provides the digital description of 3-dimensional (3D) replicas. The data are not intended to be used to assess specimens. When assessing specimens, the 3D replicas are to be used.

A.2 Processes of measurement and analysis

A.2.1 A 3-dimensional scanning system was used to measure digital images of ISO wrinkle replicas as shown in [Figure A.1](#). Specifications for the scanning system are given in [Table A.1](#).



Figure A.1 — 3-Dimensional scanning system

Table A.1 — Specification of the 3-dimensional scanning system

Camera	1 024 × 768 pixels, black and white (B/W)
Special pattern	Structural beam by halogen lamp
Adjustment of focus	Using the laser-point light source
Measurement time	Approximately 70 s to 80 s
Resolution	±0,05 mm

A.2.2 The measuring area is shown in [Figure A.2](#).