



Designation: F1373 – 93 (Reapproved 2012)

Standard Test Method for Determination of Cycle Life of Automatic Valves for Gas Distribution System Components¹

This standard is issued under the fixed designation F1373; the number immediately following the designation indicates the year of original adoption or, in the case of revision, the year of last revision. A number in parentheses indicates the year of last reapproval. A superscript epsilon (ϵ) indicates an editorial change since the last revision or reapproval.

INTRODUCTION

Semiconductor clean rooms are serviced by high-purity gas distribution systems. This test method presents a procedure that may be applied for the evaluation of one or more components considered for use in such systems.

1. Scope

1.1 This test method covers the testing of automatic valves for cycle life utilizing static, no-flow conditions. This no-flow condition is felt to be a realistic test to determine the valve's cycle life.

1.2 This test method applies to automatically operated valves. It is intended to measure the cycle life of the valve itself including the seat and body sealing. It does not include cycle testing of the actuator. Testing must include both pressure testing and helium leak testing and must include vacuum test conditions when appropriate. This test method may be applied to a broad range of valve sizes.

1.3 Limitations:

1.3.1 This test is not designed to evaluate the performance of the actuator. This test method addresses the gas system contamination aspects of the valve performance, that is, seat and body leakage and diaphragm or bellows failure. If the actuator fails during the evaluation, the valve is deemed as a failure.

1.3.2 While the requirements of a valve's performance might include items such as particulate generation levels, this test method only attempts to evaluate cycle life and performance degradation as they relate to the ability of the valve to operate and shut off flow.

1.3.3 This test method is written with the assumption that the operator understands the use of the apparatus at a level equivalent to six months of experience.

1.4 The values stated in SI units are to be regarded as the standard. The inch-pound units given in parentheses are for information only.

¹ This test method is under the jurisdiction of ASTM Committee F01 on Electronics and is the direct responsibility of Subcommittee F01.10 on Contamination Control.

Current edition approved July 1, 2012. Published August 2012. Originally approved in 1992. Last previous edition approved in 2005 as F1373 – 93(2005). DOI: 10.1520/F1373-93R12.

1.5 This standard does not purport to address all of the safety concerns, if any, associated with its use. It is the responsibility of the user of this standard to establish appropriate safety and health practices and determine the applicability of regulatory limitations prior to use. Specific hazard statements are given in Section 7.

2. Referenced Document

2.1 SEMATECH Standard:

2.1.1 Test Method for Determination of Helium Leak Rate for Gas Distribution Systems Components, Provisional SEMASPEC #90120391 B-STD. Feb. 22, 1993.²

3. Terminology

3.1 Definitions of Terms Specific to This Standard:

3.1.1 *actuation cycle*—operation of valve from fully opened to fully closed and back to fully opened.

3.1.2 *actuator*— a gas (compressed air nitrogen)-operated device connected to the valve stem to open and close the valve.

3.1.3 *actuator pressure*—range of actuator gas line pressure required to fully open and close the valve.

3.1.4 *automatic valve*—a valve with an actuation device that can be operated remotely, such as a pneumatically or electrically controlled valve.

3.1.5 *cycle life*—the cycle life of a valve involves two characteristics: catastrophic valve failure, that is a single value; and a degraded performance, that is, a plot of helium leak rate versus cycles.

3.1.6 *failure*—the termination of the ability of the valve to perform its required function.

3.1.7 *failure mode*—the mode by which a failure is observed to occur.

² Available from SEMATECH, 2706 Montopolis Dr., Austin, TX 78741-6499.

3.1.7.1 *Discussion*—Failure mode types include a *catastrophic failure* that is both sudden and complete and *degraded failure* that is gradual, partial, or both.

3.1.8 *standard conditions*—101.3 kPa, 0.0°C (14.73 psia, 32.0°F).

3.1.9 *valve*—any component designed to provide positive shutoff of fluid media with the capability of being externally operated.

4. Significance and Use

4.1 The purpose of this test method is to define a procedure for testing components being considered for installation into a high-purity gas distribution system. Application of this test method is expected to yield comparable data among components tested for the purposes of qualification for this installation.

5. Apparatus

5.1 *Helium Mass Spectrometer Leak Detector*.

5.2 *Cycle Counter*.

5.3 *Upstream and Downstream Pressure Indicators or Transducers*, capable of handling the test pressure ranges; a vacuum pump for vacuum service valves, an isolation valve and test valve, some pressure transducers or gages, and a cycle controller to provide consistent cycling are required.

5.4 *Instrument to Detect Failure of the Valve to Hold Pressure*, for example, a data logger tied to the outlet pressure transducer. A data logging instrument is preferred but any instrument such as a dual strip chart recorder capable of detecting the failure is acceptable.

6. Reagents and Materials

6.1 *Air*—a high pressure supply of clean dry air (CDA) or nitrogen filtered to $< 0.02 \mu\text{m}$.

6.2 *Actuation Gas Supply*, is required.

6.3 *Helium Supply*, is required, though for helium leak tests only.

7. Hazards

7.1 The test must be performed in an environment and manner that prevents injury, or external laboratory damage.

NOTE 1—**Precaution:** During this test the valve may be tested until it fails and may release high pressure gas.

7.2 Do not use helium as the test gas for cycling. This is because helium leak rate test method is used to measure leaks in the test component.

8. Preparation of Apparatus

8.1 Construct a test stand for the determination of the cycle life of automatic valves according to the schematic drawing shown in Fig. 1. A recommended test apparatus which can be used to conduct both the cycle life and all three helium leak tests is shown in Fig. 2 (see 5.2). Dimensions between the components are also shown in Fig. 2 and a list of parts that can be used to assemble the recommended test apparatus is presented in Fig. 3 (see 5.3).

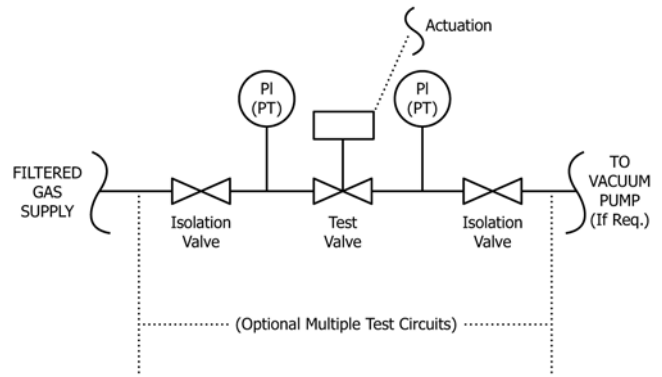

FIG. 1 Cycle Life Test Schematic

8.2 Nitrogen gas supply is filtered by an electronics grade high purity gas filter before it is delivered to the test valve through the isolation valve. The test valve is isolated between two isolation valves to allow for pressurization of the test component during cycling and leak testing. Helium gas needed for leak testing is provided from an ultra high purity helium gas cylinder.

8.3 The test component is installed inside a borosilicate bell jar placed above a stainless steel base plate to provide a leak-tight enclosure required for both the inboard and outboard helium leak tests. Ports are provided in the base plate for the inlet and outlet lines of the test component, for the actuator line, and for a port for the actuator exhaust to release the exhaust outside the bell jar. The base plate is sealed to the bell jar by a rubber gasket during outboard leak testing of the test component.

8.4 Both the inlet and outlet pressures are measured immediately upstream and downstream of the test valve by two electronic pressure transducers. These pressure transducers are connected to two digital readouts to display inlet and outlet pressures. Electronic readouts are connected to a dual channel strip chart recorder to continuously monitor the inlet and outlet pressures.

8.5 A thermocouple is connected to a digital readout unit to directly display and read the ambient temperature.

8.6 As shown in Fig. 2, the nitrogen gas supply is shut off before helium is delivered to either pressurize the test component for outboard leak testing or for spraying helium around the test specimen for inboard leak testing. A helium leak detector that can measure helium leak rates down to $2 \times 10^{-11} \text{ atm-cm}^3/\text{s}$ (He) is to be used for the leak measurements.

9. Calibration

9.1 Calibrate instruments regularly in accordance with manufacturer's instructions.

10. Test Conditions

10.1 Maintain test temperature between 18 and 26°C (64 and 78°F). Environmental temperature within this range is not expected to have any measurable effect on valve performance.