



**International
Standard**

ISO 17294-1

**Water quality — Application of
inductively coupled plasma mass
spectrometry (ICP-MS) —**

**Part 1:
General requirements**

*Qualité de l'eau — Application de la spectrométrie de masse avec
plasma à couplage inductif (ICP-MS) —*

Partie 1: Exigences générales

[ISO 17294-1:2024](https://standards.iteh.ai/standards/iso/2f448873-88ff-49d8-8b93-a31a8b5b39a5/iso-17294-1-2024)

<https://standards.iteh.ai/catalog/standards/iso/2f448873-88ff-49d8-8b93-a31a8b5b39a5/iso-17294-1-2024>

**Second edition
2024-03**

iTeh Standards
(<https://standards.iteh.ai>)
Document Preview

[ISO 17294-1:2024](https://standards.iteh.ai/catalog/standards/iso/2f448873-88ff-49d8-8b93-a31a8b5b39a5/iso-17294-1-2024)

<https://standards.iteh.ai/catalog/standards/iso/2f448873-88ff-49d8-8b93-a31a8b5b39a5/iso-17294-1-2024>



COPYRIGHT PROTECTED DOCUMENT

© ISO 2024

All rights reserved. Unless otherwise specified, or required in the context of its implementation, no part of this publication may be reproduced or utilized otherwise in any form or by any means, electronic or mechanical, including photocopying, or posting on the internet or an intranet, without prior written permission. Permission can be requested from either ISO at the address below or ISO's member body in the country of the requester.

ISO copyright office
CP 401 • Ch. de Blandonnet 8
CH-1214 Vernier, Geneva
Phone: +41 22 749 01 11
Email: copyright@iso.org
Website: www.iso.org

Published in Switzerland

Contents

	Page
Foreword	v
Introduction	vi
1 Scope	1
2 Normative references	1
3 Terms and definitions	1
4 Principle	3
5 Apparatus	4
5.1 General.....	4
5.2 Sample introduction.....	4
5.2.1 General.....	4
5.2.2 Pump.....	5
5.2.3 Nebulizer.....	5
5.2.4 Spray chamber.....	6
5.2.5 Other systems.....	6
5.3 Torch and plasma.....	6
5.4 Gas and gas control.....	7
5.5 Generator.....	7
5.6 Transfer of the ions to the mass spectrometer.....	7
5.7 Mass spectrometer.....	8
5.7.1 General.....	8
5.7.2 Lens system.....	8
5.7.3 Collision or reaction cell.....	8
5.7.4 Analyser.....	8
5.7.5 Detector.....	9
5.7.6 Alternative mass spectrometers and types of instruments.....	10
5.8 Signal processing and instrument control.....	11
6 Interferences by concomitant elements	11
6.1 General.....	11
6.2 Spectral interferences.....	11
6.2.1 General.....	11
6.2.2 Possible elimination strategies for polyatomic ion interferences.....	12
6.3 Non-spectral interferences.....	13
6.3.1 General.....	13
6.3.2 Interferences in the nebulization process.....	13
6.3.3 Interferences in the plasma.....	13
6.3.4 Interferences in the interface or lens area.....	14
6.3.5 Possible elimination strategies for non-spectral interferences (matrix effects).....	14
7 Adjustment of the apparatus	17
7.1 General.....	17
7.2 Tuning the apparatus.....	17
7.2.1 General.....	17
7.2.2 Alignment of the plasma.....	18
7.2.3 Mass calibration.....	18
7.2.4 Resolution.....	18
7.2.5 Detector.....	18
7.3 Verification of instrument performance criteria.....	19
8 Preparatory steps	19
8.1 General.....	19
8.2 Choice of isotopes.....	20
8.3 Choice of instrumental settings.....	20
8.4 Choice of integration time.....	21
8.5 Choice of reference elements — Internal standards.....	22

ISO 17294-1:2024(en)

8.6	Linearity and working range.....	22
8.7	Composition of calibration solutions.....	23
8.8	Method development for cool plasma conditions.....	23
8.9	Determination of the method performance.....	23
8.9.1	General.....	23
8.9.2	Instrument detection limit.....	24
8.9.3	Method detection limit.....	24
8.9.4	Precision of the method.....	24
9	Procedure.....	24
9.1	General.....	24
9.2	Calibration.....	24
9.3	Necessary solutions.....	25
9.4	Measurement.....	25
Annex A (informative)	Spectral interferences, choice of isotopes and instrument detection limits for quadrupole ICP-MS instruments.....	27
Bibliography.....		32

iTeh Standards (<https://standards.iteh.ai>) Document Preview

[ISO 17294-1:2024](https://standards.iteh.ai/catalog/standards/iso/2f448873-88ff-49d8-8b93-a31a8b5b39a5/iso-17294-1-2024)

<https://standards.iteh.ai/catalog/standards/iso/2f448873-88ff-49d8-8b93-a31a8b5b39a5/iso-17294-1-2024>

Foreword

ISO (the International Organization for Standardization) is a worldwide federation of national standards bodies (ISO member bodies). The work of preparing International Standards is normally carried out through ISO technical committees. Each member body interested in a subject for which a technical committee has been established has the right to be represented on that committee. International organizations, governmental and non-governmental, in liaison with ISO, also take part in the work. ISO collaborates closely with the International Electrotechnical Commission (IEC) on all matters of electrotechnical standardization.

The procedures used to develop this document and those intended for its further maintenance are described in the ISO/IEC Directives, Part 1. In particular, the different approval criteria needed for the different types of ISO document should be noted. This document was drafted in accordance with the editorial rules of the ISO/IEC Directives, Part 2 (see www.iso.org/directives).

ISO draws attention to the possibility that the implementation of this document may involve the use of (a) patent(s). ISO takes no position concerning the evidence, validity or applicability of any claimed patent rights in respect thereof. As of the date of publication of this document, ISO had not received notice of (a) patent(s) which may be required to implement this document. However, implementers are cautioned that this may not represent the latest information, which may be obtained from the patent database available at www.iso.org/patents. ISO shall not be held responsible for identifying any or all such patent rights.

Any trade name used in this document is information given for the convenience of users and does not constitute an endorsement.

For an explanation of the voluntary nature of standards, the meaning of ISO specific terms and expressions related to conformity assessment, as well as information about ISO's adherence to the World Trade Organization (WTO) principles in the Technical Barriers to Trade (TBT), see www.iso.org/iso/foreword.html.

This document was prepared by Technical Committee ISO/TC 147, *Water quality*, Subcommittee SC 2, *Physical, chemical and biochemical methods*, in collaboration with the European Committee for Standardization (CEN) Technical Committee CEN/TC 230, *Water analysis*, in accordance with the Agreement on technical cooperation between ISO and CEN (Vienna Agreement).

This second edition cancels and replaces the first edition (ISO 17294-1:2004), which has been technically revised.

<https://standards.iteh.ai/catalog/standards/iso/2f448873-88ff-49d8-8b93-a31a8b5b39a5/iso-17294-1-2024>

The main changes are as follows:

- scope has been revised to align with ISO 17294-2;
- text has been revised to reflect currently available instruments used in routine daily practice in many laboratories;
- [Clauses 5](#) and [6](#) have been revised to reflect the state-of-the-art equipment used to measure elements according to ISO 17294-2;
- abbreviated terms in [Clause 9](#) have been revised to align with common terms used in other standards;
- [Table A.1](#) has been updated.

A list of all parts in the ISO 17294 series can be found on the ISO website.

Any feedback or questions on this document should be directed to the user's national standards body. A complete listing of these bodies can be found at www.iso.org/members.html.

Introduction

Since the last edition of this document, new developments in metal analysis with inductively coupled plasma mass spectrometry (ICP-MS) have taken place. The use of the collision or reaction cell (CRC) technology in quadrupole ICP-MS and triple quadrupole ICP-MS has increased in laboratories. For this reason, this document has been revised and new items have been added.

The intention for the revision of this document was to focus on the instrumentation currently available and in use for determining elements according to ISO 17294-2 in daily practice in laboratories. The consequence of this starting point is that the use of correction formulae has been moved to [Annex A](#) because of its reduced importance in modern instrumentation. Many principles also apply for high-resolution or accurate mass instrumentation, although they are not described in detail in this document.

iTeh Standards (<https://standards.iteh.ai>) Document Preview

[ISO 17294-1:2024](#)

<https://standards.iteh.ai/catalog/standards/iso/2f448873-88ff-49d8-8b93-a31a8b5b39a5/iso-17294-1-2024>

Water quality — Application of inductively coupled plasma mass spectrometry (ICP-MS) —

Part 1: General requirements

1 Scope

This document specifies the principles of inductively coupled plasma mass spectrometry (ICP-MS) and provides general requirements for the use of this technique to determine elements in water, digests of sludges and sediments (e.g. digests of water as described in ISO 15587-1 or ISO 15587-2). Generally, the measurement is carried out in water, but gases, vapours or fine particulate matter can be introduced too. This document applies to the use of ICP-MS for aqueous solution analysis.

The ultimate determination of the elements is described in a separate International Standard for each series of elements and matrix. The individual clauses of this document refer the user to these guidelines for the basic principles of the method and the configuration of the instrument.

2 Normative references

The following documents are referred to in the text in such a way that some or all of their content constitutes requirements of this document. For dated references, only the edition cited applies. For undated references, the latest edition of the referenced document (including any amendments) applies.

ISO Guide 33, *Reference materials — Good practice in using reference materials*

ISO 5725-1, *Accuracy (trueness and precision) of measurement methods and results — Part 1: General principles and definitions*

ISO 6206, *Chemical products for industrial use — Sampling — Vocabulary*

3 Terms and definitions

For the purposes of this document, the terms and definitions given in ISO Guide 33, ISO 5725-1, ISO 6206 and the following apply.

ISO and IEC maintain terminology databases for use in standardization at the following addresses:

- ISO Online browsing platform: available at <https://www.iso.org/obp>
- IEC Electropedia: available at <https://www.electropedia.org/>

3.1

analyte

element(s) to be determined

3.2

blank calibration solution

solution prepared in the same way as the *calibration solution* (3.3) but leaving out the *analyte* (3.1)

3.3

calibration solution

solution used to calibrate the instrument, prepared from a *stock solution(s)* (3.16) or from a certified standard

3.4

calibration check solution

solution of known composition within the range of the *calibration solution* (3.3) but prepared independently

3.5

determination

entire process from preparing the *test sample solution* (3.18) up to and including the measurement and calculation of the final *result* (3.14)

3.6

instrument detection limit

L_{DI}
smallest concentration that can be detected with a defined statistical probability using a contaminant-free instrument and a *blank calibration solution* (3.2)

3.7

linearity

functional relationship between the indicated values and the contents

3.8

calibration verification solution

solution with a known concentration of the matrix components compared to the *calibration solutions* (3.4), but having an *analyte* (3.1) concentration half that of the (highest) calibration solution

3.9

method detection limit

L_{DM}
smallest *analyte* (3.1) concentration that can be detected with a specified analytical method with a defined statistical probability

3.10

net intensity

I
signal obtained after background correction

3.11

optimization solution

solution serving for mass calibration and for the optimization of the apparatus conditions

EXAMPLE Adjustment of maximal *sensitivity* (3.15) with respect to minimal oxide formation rate and minimal formation of doubly charged ions.

3.12

precision

closeness of agreement between independent test *results* (3.14) obtained under prescribed conditions

Note 1 to entry: Precision depends only on the distribution of random errors and does not relate to true value or the specified value.

[SOURCE: ISO 5725-1:2023, 3.12, modified — the definition has been revised and Notes 2 and 3 to entry have been removed.]

3.13

reagent blank solution

solution prepared by adding to the solvent the same amounts of reagents as those added to the *test sample solution* (3.18) and with the same final volume

3.14**result**

outcome of a measurement

Note 1 to entry: The result is typically calculated as mass concentration (U), expressed in milligrams per litre.

3.15**sensitivity**

S

ratio of the variation of the magnitude of the signal (ΔI) to the corresponding variation in the concentration of the *analyte* (3.1) (ΔC)

Note 1 to entry: Sensitivity is calculated as shown in [Formula \(1\)](#):

$$S = \frac{\Delta I}{\Delta C} \quad (1)$$

3.16**stock solution**

solution with accurately known *analyte* (3.1) concentration(s), prepared from pure chemicals

Note 1 to entry: Stock solutions are reference materials within the meaning of ISO Guide 30.

Note 2 to entry: Pure chemicals are those which have the highest available purity and known stoichiometry and for which the content of analyte and contaminants should be known with an established degree of certainty.

3.17**test sample**

sample prepared from the laboratory sample

Note 1 to entry: The sample can be prepared, for example, by grinding or homogenizing.

3.18**test sample solution**

solution prepared with the fraction (test portion) of the *test sample* (3.17) according to the appropriate specifications, such that it can be used for the envisaged measurement

<https://standards.iteh.ai/catalog/standards/iso/2f448873-88ff-49d8-8b93-a31a8b5b39a5/iso-17294-1-2024>

4 Principle

In the present context, a plasma is a small cloud of hot (6 000 K to 10 000 K) and partly ionized (approximately 1 %) argon gas. Cool plasmas have temperatures of only about 2 500 K. The plasma is sustained by a radio-frequency field. The sample is brought into the plasma as an aerosol. Liquid samples are converted into an aerosol using a nebulizer. In the plasma, the solvent of the sample evaporates, and the compounds present decompose into the constituent atoms (dissociation, atomization). The analyte atoms are in most cases almost completely ionized.

In the mass spectrometer, typically equipped with a collision or reaction cell (CRC) and quadrupole, the ions are separated and the elements identified according to their mass-to-charge ratio, m/z , while the concentration of the element is proportional to the number of ions.

ICP-MS is a relative technique. The proportionality factor between response and analyte concentration relates to the fact that only a fraction of the analyte atoms that are aspirated reach the detector as an ion. The proportionality factor is determined by measuring calibration solutions (calibration).

With instruments equipped with a magnetic sector field, higher mass resolution spectra can be obtained. This can help to separate isotopes of interest from interfering species.

5 Apparatus

5.1 General

The principal components of the equipment used for ICP-MS is shown in [Figure 1](#) in the form of a schematic block diagram.

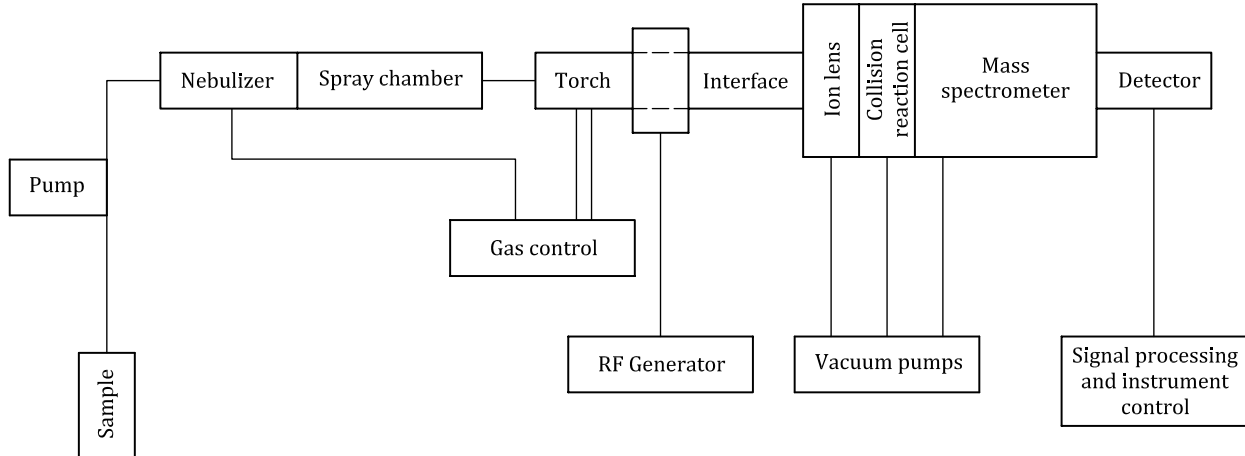

Figure 1 — Schematic block diagram of an ICP-MS instrument

5.2 Sample introduction

5.2.1 General

To introduce solutions to be measured into the plasma, a peristaltic pump, a nebulizer and a spray chamber are generally used. The pump supplies the solution to the nebulizer. In the nebulizer, the solution is converted into an aerosol by an (argon) gas flow, except when an ultrasonic nebulizer is used; see [5.2.3](#). Large drops are removed from the aerosol in the spray chamber by means of collisions with the walls or other parts of the chamber and they are drained off as liquid. The resulting aerosol is then transferred into the plasma via the injector tube of the torch (see [5.3](#)) with the help of the nebulizer gas (sample-introduction gas).

The sample introduction system is designed in such a way that:

- the average mass per aerosol droplet is as low as possible;
- the mass of the aerosol transported to the plasma in each period of time is as constant as possible;
- the droplet size distribution and the added mass of the aerosol in each period of time is, as far as possible, independent of the solution to be measured (matrix effect, see [6.3](#));
- the time the aerosol takes to stabilize after introduction in the spray chamber of a solution is as short as possible;
- the parts of the system in contact with the sample or the aerosol are not corroded, degraded or contaminated by the solution;
- carry-over from one sample to subsequent samples is minimized.

The components of the sample introduction system shall be able to withstand any corrosive substances in the solutions, such as strong acids. The material used for pump tubing should be resistant to dissolution and chemical attack by the solution to be nebulized. Components that come into contact with the solution are often made of special plastics. The use of glass and quartz shall be avoided if hydrofluoric acid is present in the test solution. In those cases, the nebulizer, spray chamber and torch injector tube shall be made of suitable inert materials.

The various components of the sample introduction system are discussed hereafter in relation to these requirements and some examples are compared.

5.2.2 Pump

The use of a peristaltic pump to feed the solutions [e.g. sample, reference elements solutions (8.5)] to the nebulizer is not necessary with some nebulizers (see 5.2.3) but is desirable in almost all cases in order to render the supply of the solution less dependent on the composition of the solution. A sampling pump is used on all modern instruments.

It is advisable to use a peristaltic pump having the largest possible number of rollers and a velocity as high as possible to avoid major surges in the supply of the solution. The quantity of solution that is pumped is mostly between 0,1 ml/min and 1,0 ml/min and typically around 0,4 ml/min to 0,5 ml/min.

5.2.3 Nebulizer

The most common nebulizers are the concentric nebulizer (e.g. Meinhard¹⁾), the crossflow nebulizer, the V-groove nebulizer and the ultrasonic nebulizer (USN). The first one can be used in self-aspiration mode and the crossflow nebulizer can be used without a pump (but seldom are). Nebulizers (except for the USN) can be made of glass or of hard, inert plastic such as PFA.

The concentric nebulizer consists of two concentric tubes, the outer one being narrowed at the end. The solution flows through the central tube and the nebulizer gas (see 5.4) through the tube around it, creating a region of lower pressure around the tip of the central tube and disrupting the solution flow into small droplets (the aerosol). This nebulizer performs best with solutions with a low content of dissolved matter, although there are also models that are less sensitive to significant amounts of dissolved matter in the solution to be nebulized.

The crossflow nebulizer consists of two capillary tubes mounted at a right angle, one being used for the supply of the solution and the other for the supply of the nebulizer gas. Depending on the distance between the openings of the capillary tubes and their diameters, the nebulizer can be self-aspirating. With larger diameters, the chance of blockages occurring is of course smaller, but a pump shall be used to supply the solution.

In the V-groove nebulizer, the solution flows through a vertical V-groove to the outflow opening of the nebulizer gas. The solution is nebulized by the high linear speed of this gas at the very small diameter outflow opening. The V-groove nebulizer was developed for solutions with a high concentration of dissolved matter and/or with suspended particles, although it is also used successfully with diluted and/or homogenous solutions. Similar nebulizers are the Burgener²⁾ nebulizer and the cone-spray nebulizer, with similar outer shapes as the concentric nebulizer. With these nebulizers, the solution flows out into a cone-shaped area at the tip of the nebulizer instead of a V-groove and flows over the outflow opening of the nebulizer gas.

In the ultrasonic nebulizer, the solution is pumped through a tube that ends near the transducer plate that vibrates at an ultrasonic frequency. The amount of aerosol produced (the efficiency) is typically 10 % to 20 % of the quantity of the pumped solution. This is so high that the aerosol shall be dried (desolvated) before being introduced into the plasma, which would otherwise be extinguished. The aerosol is transported to the plasma by the nebulizer gas. Disadvantages of the ultrasonic nebulizer include its greater susceptibility to matrix effects, diminished tolerance to high dissolved solid contents and a longer rinsing time (i.e. Ag, B, Hg, Mo).

For the other nebulizers previously described, the efficiency is typically only a few per cent. The efficiency increases when the solution introduction rate is decreased. Specially designed concentric micro-nebulizers made of special types of hard plastic operate at solution flow rates of 10 µl/min to 100 µl/min and efficiencies

1) The Meinhard nebulizer is an example of a suitable product available commercially. This information is given for the convenience of users of this document and does not constitute an endorsement by ISO of this product. Equivalent products may be used if they can be shown to lead to the same results.

2) The Burgener nebulizer is an example of a suitable product available commercially. This information is given for the convenience of users of this document and does not constitute an endorsement by ISO of this product. Equivalent products may be used if they can be shown to lead to the same results.

approaching 100 %. These concentric micro-nebulizers often show a very good precision (low coefficient of variation of the signal) and can also be combined with a membrane desolvator [see 6.2.1, a)].

Several other types of nebulizers may be used for specific applications.

5.2.4 Spray chamber

In the spray chamber [e.g. Scott (double concentric tubes), cyclonic or impact bead], the larger drops of the aerosol are drained off in liquid form. To create and keep over-pressure in the chamber, the liquid shall be removed via a sealed drain tube utilizing hydrostatic pressure or by pumping. The internal diameter of the drain tubing should be higher than that of the sample uptake tubing to ensure that no liquid remains in the spray chamber. The liquid shall be removed evenly to avoid pressure variations in the chamber, which can result in variations in the signal.

By cooling the spray chamber to 2 °C to 5 °C, the water vapour formed in the nebulization process condenses, thereby reducing the water load of the plasma. This results in a reduction in the formation of interfering polyatomic ions (oxides); see 6.2.2.

5.2.5 Other systems

There are other types of introduction systems for particular applications. These include laser or spark ablation of a solid sample, evaporation of the solution by means of a graphite furnace or a metal filament, introduction of a gas or a gas form of the analyte (as in the hydride generation technique), systems for the direct introduction of solid matter into the plasma (e.g. in the form of a slurry of a finely dispersed powder in a solvent) and the introduction with a graphite rod directly into the plasma.

With the direct injection nebulizer (DIN), a pneumatic concentric micro-nebulizer, instead of the inner tube (injector; see 5.3), is placed in the torch. It has a sample introduction efficiency of almost 100 %, with a sample uptake rate of typically 10 µl/min. A DIN can be used for techniques giving transient signals (e.g. coupling to chromatographic or flow injection devices) and for minimizing the memory effects of, for instance, silver, boron, molybdenum and mercury. These systems are not discussed in this document.

5.3 Torch and plasma

The torch consists of three concentric tubes and can be designed as a monoblock or demountable unit. Quartz is the material generally used, but also high purity ceramic torches are available. Sometimes the innermost tube (the sample introduction tube or injector tube) is made of inert material, for example aluminium oxide or sapphire. It usually ends at 4 mm to 5 mm before the first winding of the coil. The aerosol produced in the sample introduction system flows through the sample introduction tube, transported by an (argon) gas flow (the nebulizer gas) with a flow rate of approximately 0,5 l/min to 1,5 l/min.

The auxiliary gas flows between the sample introduction tube and the middle tube with a flow rate of up to 3 l/min. Whether or not an auxiliary gas or humidification of the argon flow is used depends on, for example, the type of device concerned, the solvent used and the salt concentration. The function of the auxiliary gas is to increase the separation of the plasma and the torch and thus reduce the temperature at the end of the injector (and intermediate) tube. This avoids deposits of dissolved material or the build-up of carbon (when organic solvents are nebulized) on the injector tube.

The plasma gas flows between the middle and outermost tubes with a flow rate of 12 l/min to 20 l/min. The function of the plasma gas is to maintain the plasma and to cool the outer tube of the torch.

Around the top of the torch, there is a cooled coil with two to five windings. A high-frequency current flows through the coil and excites the plasma (see 5.5).

The torch is generally placed in a separate metal compartment. This compartment shall be connected to an exhaust system (extraction) because of the production of heat and harmful gases (including ozone). The metal of the compartment protects the users and the instrument (electronics) against the high-frequency radiation, which is released from the coil, and against the ultraviolet radiation emitted by the plasma. A camera, a lens or a special window, covered with a darkened glass to protect the observer's eyes from the