**Paints and varnishes — Determination
of the resistance of coatings to
pressure water-jetting**

*Peintures et vernis — Détermination de la résistance des revêtements
à un jet d'eau sous pression*

iTeh STANDARD PREVIEW
(standards.iteh.ai)

[ISO 16925:2021](https://standards.iteh.ai/catalog/standards/sist/5fd01a2c-aa3c-447b-92fa-7252801e0fca/iso-16925-2021)

<https://standards.iteh.ai/catalog/standards/sist/5fd01a2c-aa3c-447b-92fa-7252801e0fca/iso-16925-2021>



iTeh STANDARD PREVIEW
(standards.iteh.ai)

ISO 16925:2021

<https://standards.iteh.ai/catalog/standards/sist/5fd01a2c-aa3c-447b-92fa-7252801e0fca/iso-16925-2021>



COPYRIGHT PROTECTED DOCUMENT

© ISO 2021

All rights reserved. Unless otherwise specified, or required in the context of its implementation, no part of this publication may be reproduced or utilized otherwise in any form or by any means, electronic or mechanical, including photocopying, or posting on the internet or an intranet, without prior written permission. Permission can be requested from either ISO at the address below or ISO's member body in the country of the requester.

ISO copyright office
CP 401 • Ch. de Blandonnet 8
CH-1214 Vernier, Geneva
Phone: +41 22 749 01 11
Email: copyright@iso.org
Website: www.iso.org

Published in Switzerland

Contents

	Page
Foreword.....	iv
1 Scope.....	1
2 Normative references.....	1
3 Terms and definitions.....	1
4 Principle.....	1
5 Apparatus and materials.....	2
6 Sampling.....	3
7 Preparation of test specimens.....	4
7.1 Test specimens.....	4
7.2 Preparation and coating.....	4
7.3 Thickness of coating.....	4
8 Procedure.....	4
8.1 Introducing the cut or the scribe.....	4
8.2 Testing.....	5
9 Evaluation.....	6
9.1 General.....	6
9.2 Evaluation with illustrations to compare.....	6
10 Precision.....	13
10.1 General.....	13
10.2 Repeatability limit (r).....	13
10.3 Reproducibility limit (R).....	13
11 Designation.....	13
12 Test report.....	14
Annex A (normative) Calibration of the test apparatus.....	15

Foreword

ISO (the International Organization for Standardization) is a worldwide federation of national standards bodies (ISO member bodies). The work of preparing International Standards is normally carried out through ISO technical committees. Each member body interested in a subject for which a technical committee has been established has the right to be represented on that committee. International organizations, governmental and non-governmental, in liaison with ISO, also take part in the work. ISO collaborates closely with the International Electrotechnical Commission (IEC) on all matters of electrotechnical standardization.

The procedures used to develop this document and those intended for its further maintenance are described in the ISO/IEC Directives, Part 1. In particular, the different approval criteria needed for the different types of ISO documents should be noted. This document was drafted in accordance with the editorial rules of the ISO/IEC Directives, Part 2 (see www.iso.org/directives).

Attention is drawn to the possibility that some of the elements of this document may be the subject of patent rights. ISO shall not be held responsible for identifying any or all such patent rights. Details of any patent rights identified during the development of the document will be in the Introduction and/or on the ISO list of patent declarations received (see www.iso.org/patents).

Any trade name used in this document is information given for the convenience of users and does not constitute an endorsement.

For an explanation of the voluntary nature of standards, the meaning of ISO specific terms and expressions related to conformity assessment, as well as information about ISO's adherence to the World Trade Organization (WTO) principles in the Technical Barriers to Trade (TBT), see www.iso.org/iso/foreword.html.

This document was prepared by Technical Committee ISO/TC 35, *Paints and varnishes*, Subcommittee SC 9, *General test methods for paints and varnishes*, in collaboration with the European Committee for Standardization (CEN) Technical Committee CEN/TC 139 *Paints and varnishes*, in accordance with the Agreement on technical cooperation between ISO and CEN (Vienna Agreement).

This second edition cancels and replaces the first edition (ISO 16925:2014), which has been technically revised.

The main changes are as follows:

- the definitions “fracture strength”, “adhesion” and “cohesion” have been deleted from [Clause 3](#) because they are not used in this document;
- in [5.1](#) and in [A.2.4](#) the data for the adjustment of the mass flow rate have been updated;
- in [8.2](#) and in the test report the agreement of the mass flow rate has been deleted because it is given by the test method and need not to be agreed;
- the volumetric flow rate has been changed to mass flow rate in several places;
- the normative references have been updated and the text has been editorially revised.

Any feedback or questions on this document should be directed to the user's national standards body. A complete listing of these bodies can be found at www.iso.org/members.html.

Paints and varnishes — Determination of the resistance of coatings to pressure water-jetting

1 Scope

This document specifies a test method for the evaluation of the resistance of coatings to pressure water-jetting. The test method simulates the effects pressure water-jetting has on a coating.

2 Normative references

The following documents are referred to in the text in such a way that some or all of their content constitutes requirements of this document. For dated references, only the edition cited applies. For undated references, the latest edition of the referenced document (including any amendments) applies.

ISO 1513, *Paints and varnishes — Examination and preparation of test samples*

ISO 2808, *Paints and varnishes — Determination of film thickness*

ISO 4618, *Paints and varnishes — Terms and definitions*

ISO 15528, *Paints, varnishes and raw materials for paints and varnishes — Sampling*

ISO 17872, *Paints and varnishes — Guidelines for the introduction of scribe marks through coatings on metallic panels for corrosion testing*

ISO 16925:2021

3 Terms and definitions

<https://standards.iteh.ai/catalog/standards/sist/5fd01a2c-aa3c-447b-92fa-7252801e0fca/iso-16925-2021>

For the purposes of this document, the terms and definitions given in ISO 4618 apply.

ISO and IEC maintain terminology databases for use in standardization at the following addresses:

- ISO Online browsing platform: available at <https://www.iso.org/obp>
- IEC Electropedia: available at <https://www.electropedia.org/>

4 Principle

The resistance of a coated test specimen to the loss of adhesive strength is tested by means of defined pressure water-jetting.

The extent of the damage of the test specimen primarily depends on, besides the adhesive strength, the space between nozzle and test piece, the mass flow rate, the test time, the geometry of the nozzle, the impact area, the angle of impact, and the water temperature of the jet, as well as the cutting and scribing tool.

The evaluation is carried out by means of a visual comparison of pictures, in which characteristic values are related to the peeled-off areas.

The parting line (plane) of the peeling shall be indicated in the test report (e.g. substrate/priming coat).

5 Apparatus and materials

Ordinary laboratory apparatus, together with the following.

5.1 Pressure water-jet, consisting of a high-pressure pump and a nozzle.

A high-pressure pump conveys the water from a storage bin. To avoid influences from variations in pressure, it is necessary that the pressure and the mass flow rate be adjustable at the nozzle described below.

The water temperature shall be adjustable to ± 2 °C.

The temperature shall be adjusted in accordance with [Annex A](#). Necessary safety devices on the pressure side of the unit, e.g. pressure relief valve and by-pass valve, shall exist. If the jetting is unsteady, a flow calming section may be installed in front of the nozzle. A pulsation of the water jet at the opening of the pump is inadmissible. In order to reach a reproducible result, the nozzle shall be solidly mechanically fixed and the test specimen shall be secured against slipping. For the adjustment of the mass flow rate, a nozzle with a jet angle of 40° and a mass flow rate of 6 kg/min at 2 MPa (20 bar) is required (see [Annex A](#)).

The following technical data should be attainable:

- mass flow rate: 8 kg/min to 14 kg/min
- pressure: 4 MPa (40 bar) to 13 MPa (130 bar)
- temperature: 20 °C to 80 °C
- jetting time: 10 s to 300 s

[Figure 1](#) shows the schematic construction of a pressure water-jet apparatus which is specially built for these tests.

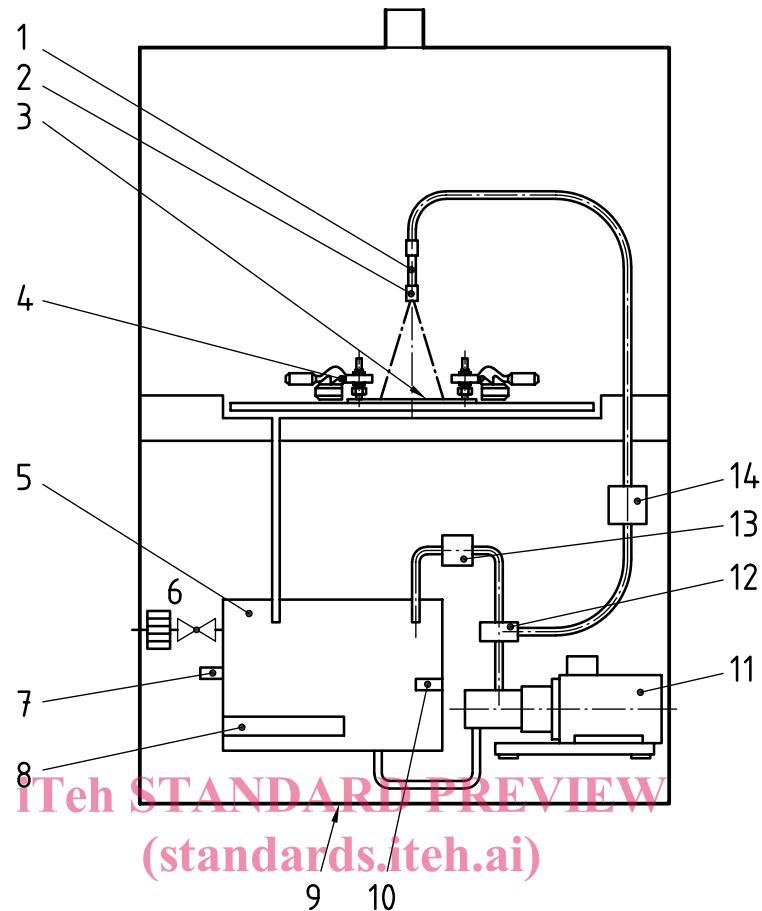
**Key**

- | | | | |
|---|--|----|-----------------------|
| 1 | flow calming section | 8 | heating |
| 2 | high-pressure valve, height adjustable | 9 | base frame, moveable |
| 3 | test specimen | 10 | temperature sensor |
| 4 | clamping element | 11 | high-pressure pump |
| 5 | feed tank | 12 | by-pass valve |
| 6 | floating valve with filter | 13 | pressure relief valve |
| 7 | water shortage safeguard | 14 | pressure transmitter |

Figure 1 — Schematic construction of a pressure water-jet apparatus

5.2 Cutting or scribing tool, to be agreed by the interested parties.

The following cutting and scribing tools are appropriate: cutter knife ("C"), scribing tool according to van Laar ("L") or scribing tool according to Sikkens ("S"), in accordance with ISO 17872.

The tool should be safely usable.

5.3 Time measuring device (stopwatch).

6 Sampling

Take a representative sample of the product being tested in accordance with ISO 15528.

Examine and prepare each sample for testing in accordance with ISO 1513.

7 Preparation of test specimens

7.1 Test specimens

The test specimens should preferably be plane. The size of the test specimens as well as the number of tests shall be agreed by the interested parties.

Test specimens (building components) can have different adhesive strengths. It is recommended that different parts of the test specimen (building components) be tested.

7.2 Preparation and coating

The conditions of coating, drying/hardening, as well as stoving, shall be agreed.

Before testing, the coated test specimens shall be conditioned either 48 h at 60 °C or 7 days at room temperature. In case of conditioning at 60 °C, the specimen shall be cooled down to room temperature before the cut or scribe (see 8.1) is introduced.

7.3 Thickness of coating

Determine the dry film thickness of the coating, in micrometres, in accordance with one of the procedures specified in ISO 2808.

8 Procedure

iTeh STANDARD PREVIEW

(standards.iteh.ai)

8.1 Introducing the cut or the scribe

Make sure that the test specimen is securely fastened when introducing the cut or the scribe.

Introduce both of the cuts or scribes vertically through the coating into the substrate using the cutting or scribing tool, as shown in Figure 2. The depth of the cut or scribe into the substrate should be as minimal as possible. The length of the first cut or scribe shall be at least 100 mm, if the geometry of the part allows that. At an angle, introduce a second cut or scribe with a minimum length of 20 mm. The cuts or scribes shall be introduced straight-line at an angle of approximately 30°. An automatic cutting or scribing device may be used. Residues of the coating shall be removed from the cut or scribe.

NOTE The depth of the cut or scribe into the substrate influences the result.

The cutting or scribing tools should be checked regularly and replaced if necessary.

Dimensions in millimetres

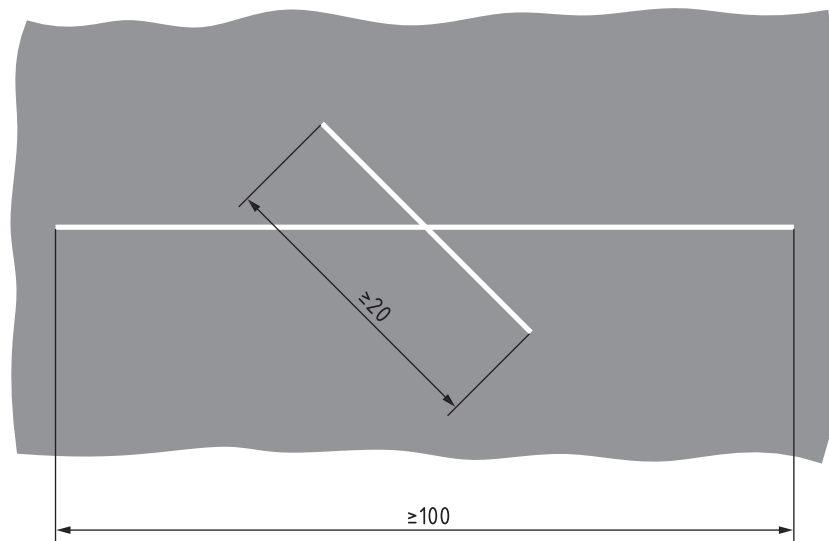

Figure 2 — Introducing the cuts or scribes (St Andrew's cross)

8.2 Testing

After inserting the test specimen into the apparatus (e.g. using a spacer block), calibrate the space between test specimen and nozzle.

Operate the pressure water-jetting apparatus at room temperature.

Three test methods (A, B, or C – see [Table 1](#)) are preferred as well as three possible tools (C, L, or S – see [5.2](#)). The test method to be applied and the scribing or cutting tool to be used shall be agreed.

Table 1 — Test methods

Test method	Water temperature °C	Impact angle	Space between nozzle and sample mm	Mass flow rate kg/min	Duration of jetting s
A	60 ± 2	$90^\circ \pm 2^\circ$	100 ± 1	$11,3 \pm 0,2$	30 ± 1
B	60 ± 2	$90^\circ \pm 2^\circ$	100 ± 1	$11,3 \pm 0,2$	60 ± 1
C	60 ± 2	$90^\circ \pm 2^\circ$	130 ± 1	$11,3 \pm 0,2$	60 ± 1

For jetting, deionized water should be used.

When using automatic and manual devices, fasten the test specimen so that the water jet impacts as shown in [Figure 3](#). The jet impacts in the middle above the point of intersection onto the longer one of both cuts/scribes.

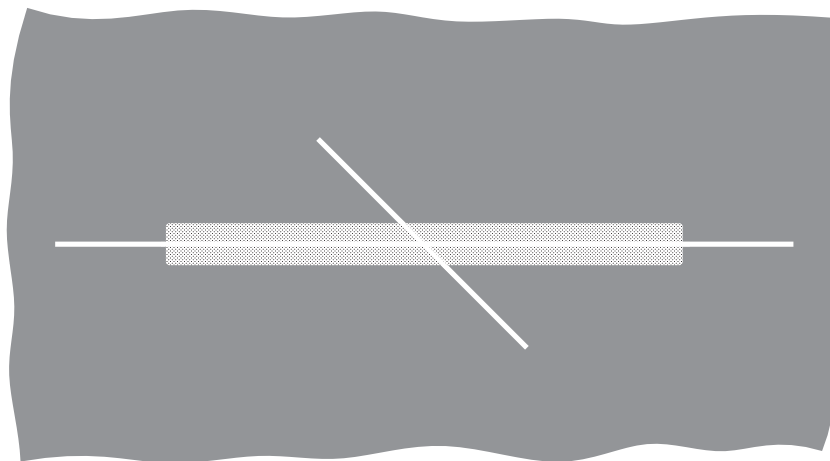

Figure 3 — Jetting area

9 Evaluation

9.1 General

Damage is recognizable when the coating loosens or flakes, regardless of which coat sustains the damage.

9.2 Evaluation with illustrations to compare

Carry out the evaluation visually, comparing the specimen with the illustrations in [Figure 4](#) to [Figure 9](#).
ISO 16925:2021
https://standards.iteh.ai/catalog/standards/sist/5fd01a2c-aa3c-447b-92fa-

In the course of the visual evaluation, a characteristic value is laid down by comparing with the illustrations in [Figure 4](#) to [Figure 9](#). A characteristic value between 1 and 5 results, depending on the degree of damage. No damage corresponds to the characteristic value 0. In addition to the evaluation, if applicable, the attribution of the separation from the main separation level or to the respective film shall be indicated.

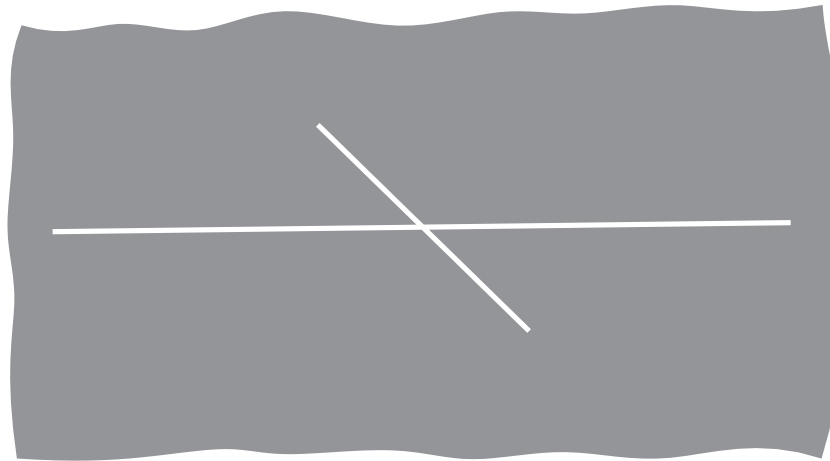

Characteristic value 0

Figure 4 — Characteristic value 0 for pressure water-jet damage

iTeh STANDARD PREVIEW
(standards.iteh.ai)

[ISO 16925:2021](https://standards.iteh.ai/catalog/standards/sist/5fd01a2c-aa3c-447b-92fa-7252801e0fca/iso-16925-2021)

<https://standards.iteh.ai/catalog/standards/sist/5fd01a2c-aa3c-447b-92fa-7252801e0fca/iso-16925-2021>