

FINAL
DRAFT

INTERNATIONAL
STANDARD

ISO/FDIS
20567-4

ISO/TC 35/SC 9

Secretariat: BSI

Voting begins on:
2022-12-12

Voting terminates on:
2023-02-06

Paints and varnishes — Determination of stone-chip resistance of coatings —

Part 4: Mobile multi-impact testing on a small testing area

iTeh STANDARD PREVIEW
(standards.iteh.ai)

[ISO/FDIS 20567-4](https://standards.iteh.ai/catalog/standards/sist/4e3ef438-a7e9-4b8c-871c-d3e44896ec90/iso-fdis-20567-4)

<https://standards.iteh.ai/catalog/standards/sist/4e3ef438-a7e9-4b8c-871c-d3e44896ec90/iso-fdis-20567-4>

RECIPIENTS OF THIS DRAFT ARE INVITED TO SUBMIT, WITH THEIR COMMENTS, NOTIFICATION OF ANY RELEVANT PATENT RIGHTS OF WHICH THEY ARE AWARE AND TO PROVIDE SUPPORTING DOCUMENTATION.

IN ADDITION TO THEIR EVALUATION AS BEING ACCEPTABLE FOR INDUSTRIAL, TECHNOLOGICAL, COMMERCIAL AND USER PURPOSES, DRAFT INTERNATIONAL STANDARDS MAY ON OCCASION HAVE TO BE CONSIDERED IN THE LIGHT OF THEIR POTENTIAL TO BECOME STANDARDS TO WHICH REFERENCE MAY BE MADE IN NATIONAL REGULATIONS.



Reference number
ISO/FDIS 20567-4:2022(E)

© ISO 2022

iTeh STANDARD PREVIEW
(standards.iteh.ai)

ISO/FDIS 20567-4

<https://standards.iteh.ai/catalog/standards/sist/4e3ef438-a7e9-4b8c-871c-d3e44896ec90/iso-fdis-20567-4>



COPYRIGHT PROTECTED DOCUMENT

© ISO 2022

All rights reserved. Unless otherwise specified, or required in the context of its implementation, no part of this publication may be reproduced or utilized otherwise in any form or by any means, electronic or mechanical, including photocopying, or posting on the internet or an intranet, without prior written permission. Permission can be requested from either ISO at the address below or ISO's member body in the country of the requester.

ISO copyright office
CP 401 • Ch. de Blandonnet 8
CH-1214 Vernier, Geneva
Phone: +41 22 749 01 11
Email: copyright@iso.org
Website: www.iso.org

Published in Switzerland

Contents

	Page
Foreword.....	iv
Introduction.....	v
1 Scope.....	1
2 Normative references.....	1
3 Terms and definitions.....	1
4 Principle.....	1
5 Apparatus and test equipment.....	2
5.1 Stone-chip resistance tester.....	2
5.2 Consumables.....	5
5.2.1 Chilled-iron grit.....	5
6 Apparatus functional test.....	6
7 Procedure.....	6
8 Evaluation.....	7
9 Test report.....	8
Annex A (normative) Pictorial reference standards for evaluating stone-chip resistance.....	9
Annex B (informative) Examples of suitable methods for removing loose coating.....	10
Bibliography.....	11

(standards.iteh.ai)

[ISO/FDIS 20567-4](https://standards.iteh.ai/catalog/standards/sist/4e3ef438-a7e9-4b8c-871c-d3e44896ec90/iso-fdis-20567-4)

<https://standards.iteh.ai/catalog/standards/sist/4e3ef438-a7e9-4b8c-871c-d3e44896ec90/iso-fdis-20567-4>

Foreword

ISO (the International Organization for Standardization) is a worldwide federation of national standards bodies (ISO member bodies). The work of preparing International Standards is normally carried out through ISO technical committees. Each member body interested in a subject for which a technical committee has been established has the right to be represented on that committee. International organizations, governmental and non-governmental, in liaison with ISO, also take part in the work. ISO collaborates closely with the International Electrotechnical Commission (IEC) on all matters of electrotechnical standardization.

The procedures used to develop this document and those intended for its further maintenance are described in the ISO/IEC Directives, Part 1. In particular, the different approval criteria needed for the different types of ISO documents should be noted. This document was drafted in accordance with the editorial rules of the ISO/IEC Directives, Part 2 (see www.iso.org/directives).

Attention is drawn to the possibility that some of the elements of this document may be the subject of patent rights. ISO shall not be held responsible for identifying any or all such patent rights. Details of any patent rights identified during the development of the document will be in the Introduction and/or on the ISO list of patent declarations received (see www.iso.org/patents).

Any trade name used in this document is information given for the convenience of users and does not constitute an endorsement.

For an explanation of the voluntary nature of standards, the meaning of ISO specific terms and expressions related to conformity assessment, as well as information about ISO's adherence to the World Trade Organization (WTO) principles in the Technical Barriers to Trade (TBT), see www.iso.org/iso/foreword.html.

This document was prepared by Technical Committee ISO/TC 35, *Paints and varnishes*, Subcommittee SC 9, *General test methods for paints and varnishes*.

A list of all parts in the ISO 20567 series can be found on the ISO website.

Any feedback or questions on this document should be directed to the user's national standards body. A complete listing of these bodies can be found at www.iso.org/members.html.

Introduction

The stone-chip resistance of the body finish is an important quality characteristic. A standard procedure for testing this characteristic is the method according to ISO 20567-1, which is performed with a stationary tester on a large test area. The method described here can be used in mobile form.

iTeh STANDARD PREVIEW
(standards.iteh.ai)

[ISO/FDIS 20567-4](https://standards.iteh.ai/catalog/standards/sist/4e3ef438-a7e9-4b8c-871c-d3e44896ec90/iso-fdis-20567-4)

<https://standards.iteh.ai/catalog/standards/sist/4e3ef438-a7e9-4b8c-871c-d3e44896ec90/iso-fdis-20567-4>

Paints and varnishes — Determination of stone-chip resistance of coatings —

Part 4: Mobile multi-impact testing on a small testing area

1 Scope

This document specifies a mobile method for evaluating the resistance of automotive finishes to chilled-iron grit projected onto the surface under test to simulate the effect of stone chipping.

Results from the test specified in this document are not comparable with results specified in ISO 20567-1.

2 Normative references

The following documents are referred to in the text in such a way that some or all of their content constitutes requirements of this document. For dated references, only the edition cited applies. For undated references, the latest edition of the referenced document (including any amendments) applies.

ISO 565, *Test sieves — Metal wire cloth, perforated metal plate and electroformed sheet — Nominal sizes of openings*

ISO 2808, *Paints and varnishes — Determination of film thickness*

ISO 4618, *Paints and varnishes — Terms and definitions*

ISO 11124-2, *Preparation of steel substrates before application of paints and related products — Specifications for metallic blast-cleaning abrasives — Part 2: Chilled-iron grit*

ISO 11125-2, *Preparation of steel substrates before application of paints and related products — Test methods for metallic blast-cleaning abrasives — Part 2: Determination of particle size distribution*

3 Terms and definitions

For the purposes of this document, the terms and definitions given in ISO 4618 apply.

ISO and IEC maintain terminology databases for use in standardization at the following addresses:

- ISO Online browsing platform: available at <https://www.iso.org/obp>
- IEC Electropedia: available at <https://www.electropedia.org/>

4 Principle

The stone-chip resistance of the coating is tested with many small, sharp-edged impact bodies, which impact in portions and are largely independent of one another. The material used in the test is chilled-iron grit, which is projected onto the coating at an angle of 90° using compressed air. The extent of the damage depends on the working pressure, the grit, the projection duration and the design of the tester. Loose fragments of coating material are removed. The degree of damage is evaluated by comparison with pictorial reference standards.

5 Apparatus and test equipment

Ordinary laboratory apparatus, together with the following shall be used.

5.1 Stone-chip resistance tester

5.1.1 Tester including pressure regulator, hoses, connections and connection adapters (see [Figures 1](#) and [2](#)).

The dosing device shall be designed such that chilled-iron grit for the test (see [7.2](#)) can be delivered in (10 ± 1) s.

The compressed air supply for the tester (compressed air line system or compressor) shall have an oil separator and water separator and shall meet the following requirements:

- output pressure min. 400 kPa;
- inner diameter of the connection hose min. 9,52 mm (3/8 inch);
- the connection hose between the compressed air supply and the tester shall be dimensioned (inside diameter, length) such that the correct working pressure can be set (see [6.1](#)).

iTeh STANDARD PREVIEW
(standards.iteh.ai)

[ISO/FDIS 20567-4](#)

<https://standards.iteh.ai/catalog/standards/sist/4e3ef438-a7e9-4b8c-871c-d3e44896ec90/iso-fdis-20567-4>

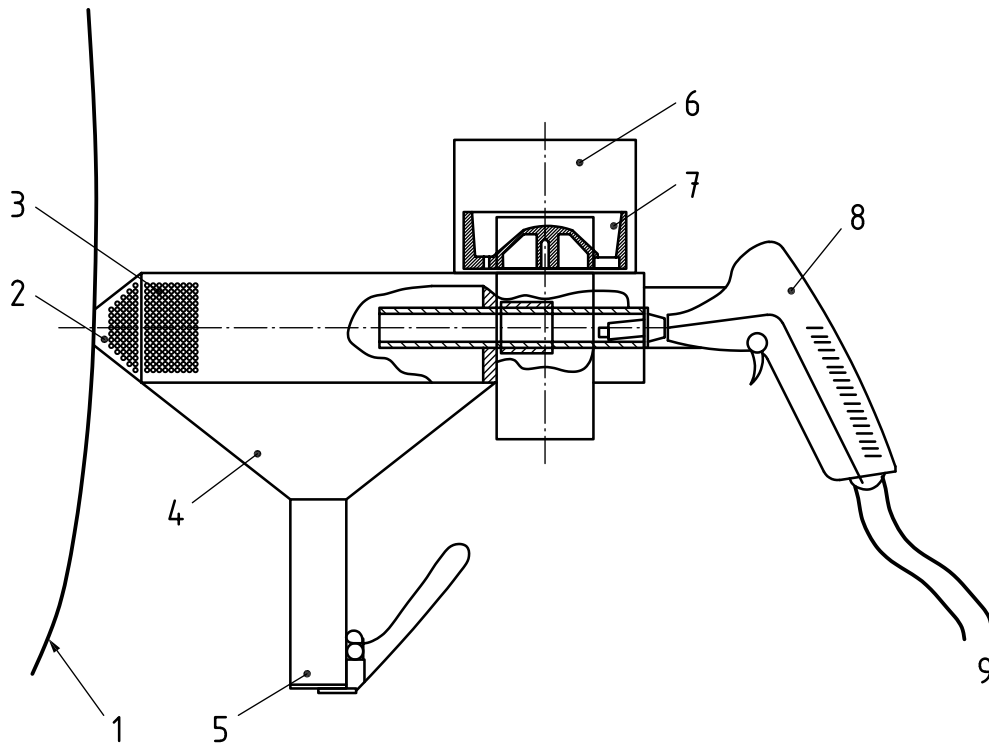

Key

- 1 sample
- 2 projection window
- 3 air outlet opening
- 4 chilled-iron grit-catching chamber
- 5 discharge flap
- 6 dosing device
- 7 drum magazine
- 8 blowing device
- 9 compressed air connection

iTeh STANDARD PREVIEW
(standards.iteh.ai)

ISO/FDIS 20567-4

<https://standards.iteh.ai/catalog/standards/sist/4e3ef438-a7e9-4b8c-871c-d3e44896cc90/iso-fdis-20567-4>

Figure 1 — Example of a mobile stone-chip tester

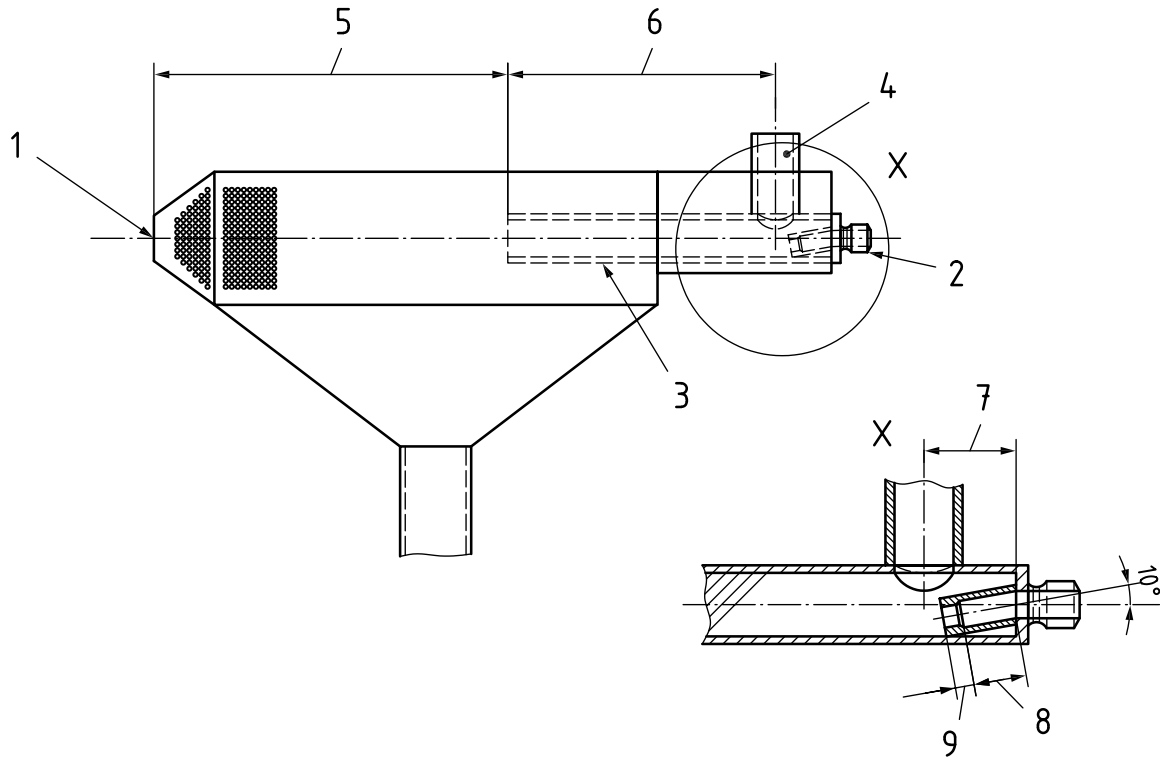

Key

- 1 projection opening (mask)
 - dimensions: 20 mm × 20 mm
- 2 compressed air connection with nozzle
- 3 grit-accelerating pipe
 - overall length: 143 mm
 - inside diameter: 16 mm
- 4 feed pipe (connected to the chilled-iron grit storage magazine)
 - length: 46 mm
 - inside diameter: 16 mm
- 5 free grit jet
 - distance between grit-accelerating pipe and mask: 155 mm
 - height and depth: 60 mm
- 6 grit acceleration section
 - distance between centre of feed pipe and the outlet opening of the grit-accelerating pipe: 118 mm
- 7 distance between nozzle inlet and centre of feed pipe: 25 mm
- 8 nozzle hole 1
 - length (centre): 15 mm
 - inside diameter: 7 mm
- 9 nozzle hole 2
 - length: 5 mm
 - inside diameter: 5 mm

Figure 2 — Grit-accelerating pipe details