



Designation: E1106–07 ~~Designation: E1106 – 12~~

## Standard Test Method for Primary Calibration of Acoustic Emission Sensors<sup>1</sup>

This standard is issued under the fixed designation E1106; the number immediately following the designation indicates the year of original adoption or, in the case of revision, the year of last revision. A number in parentheses indicates the year of last reapproval. A superscript epsilon ( $\epsilon$ ) indicates an editorial change since the last revision or reapproval.

### 1. Scope\*

1.1 This test method covers the requirements for the absolute calibration of acoustic emission (AE) sensors. The calibration yields the frequency response of a transducer to waves, at a surface, of the type normally encountered in acoustic emission work. The transducer voltage response is determined at discrete frequency intervals of approximately 10 kHz up to 1 MHz. The input is a given well-established dynamic displacement normal to the mounting surface. The units of the calibration are output voltage per unit mechanical input (displacement, velocity, or acceleration).

1-2

1.2 Units—The values stated in SI units are to be regarded as standard. No other units of measurement are included in this standard.

1.3 *This standard does not purport to address all of the safety concerns, if any, associated with its use. It is the responsibility of the user of this standard to establish appropriate safety and health practices and determine the applicability of regulatory limitations prior to use.*

### 2. Referenced Documents

2.1 *ASTM Standards:*<sup>2</sup>

E114 Practice for Ultrasonic Pulse-Echo Straight-Beam Contact Testing

E494 Practice for Measuring Ultrasonic Velocity in Materials

E650 Guide for Mounting Piezoelectric Acoustic Emission Sensors

E1316 Terminology for Nondestructive Examinations

### 3. Terminology

3.1 Refer to Terminology E1316 for terminology used in this test method.

### 4. Significance and Use

4.1 *Transfer Standards*—One purpose of this test method is for the direct calibration of displacement transducers for use as secondary standards for the calibration of AE sensors for use in nondestructive evaluation. For this purpose, the transfer standard should be high fidelity and very well behaved and understood. If this can be established, the stated accuracy should apply over the full frequency range up to 1 MHz.

NOTE 1—The stated accuracy applies only if the transfer standard returns to quiescence, following the transient input, before any wave reflected from the boundary of the calibration block returns to the transfer standard ( $\sim 100 \mu\text{s}$ ). For low frequencies with periods on the order of the time window, this condition is problematical to prove.

4.2 *Applications Sensors*—This test method may also be used for the calibration of AE sensors for use in nondestructive evaluation. Some of these sensors are less well behaved than devices suitable for a transfer standard. The stated accuracy for such devices applies in the range of 100 kHz to 1 MHz and with less accuracy below 100 kHz.

### 5. General Requirements

~~5.1A primary difficulty in any calibration of a mechanical/electrical transduction device is the determination of the mechanical motion input to the device. Using this calibration procedure, the motional input may be determined by two different~~

<sup>1</sup> This test method is under the jurisdiction of ASTM Committee E07 on Nondestructive Testing and is the direct responsibility of Subcommittee E07.04 on Acoustic Emission Method.

Current edition approved July 1, 2007. Published July 2007. Originally approved in 1986. Last previous edition approved in 2002 as E1106-86(2002)<sup>ε1</sup>. DOI: 10.1520/E1106-07.

Current edition approved June 15, 2012. Published September 2012. Originally approved in 1986. Last previous edition approved in 2007 as E1106-07. DOI: 10.1520/E1106-12.

<sup>2</sup> For referenced ASTM standards, visit the ASTM website, www.astm.org, or contact ASTM Customer Service at service@astm.org. For *Annual Book of ASTM Standards* volume information, refer to the standard's Document Summary page on the ASTM website.

\*A Summary of Changes section appears at the end of this standard.

means: theoretical calculation and measurement with an absolute displacement transducer.

**5.2 Theoretical Calculation**—Elasticity theory has been used to calculate the dynamic displacement of the surface of an infinite half-space due to a normal point-force step function in time. The solutions give the displacement of any point on the surface as a function of time, yielding a waveform for the displacement called the seismic surface pulse.

5.2.1 This calibration test method uses an approximation to this theoretical solution. See also Breckenridge

5.1 A primary difficulty in any calibration of a mechanical/electrical transduction device is the determination of the mechanical-motion input to the device. To address this difficulty, this calibration procedure uses (i) a standard transducer whose absolute sensitivity is known from its design and physical characteristics; and also (ii) a source that produces motion that approximates a waveform calculable from theory. The use of two independent sources of information confers a degree of redundancy that is employed to confirm the validity of the measurements and quantify the experimental errors. Briefly stated, the sensitivity of the transfer standard (or other sensor under test) is determined by comparison with the standard transducer, while knowledge of a part of the theoretical waveform is used as a check.

**5.2 Test Block and Mechanical Input**—The mechanical input to the sensors is obtained by pressing a glass capillary down onto the surface of a large test block until it breaks. The reasons for selecting this approach are: (a) capillary breaks are localized and short in duration, like natural acoustic emission events; and (b) use of a large block simplifies wave propagation and makes sensor output less dependent on arbitrary features of block geometry.

5.2.1 Prior to the fracture of the glass capillary, the force it exerts on the surface is distributed over an area on the order of  $2 \text{ mm} \times 0.3 \text{ mm}$ ,<sup>3</sup> and Hsu and Breckenridge. The half-space is approximated by a large metal block in the form of a circular cylinder and the point-force step function is closely approximated by the breaking of a glass capillary against the plane surface of the block. The displacement as a function of time should be calculated for the location of the device under test (on the same surface of the block as the input). This calculation should be performed using a measured value of the step function force and the elastic constants that are determined by speed of sound measurements on the block.

**5.3 Absolute Displacement Measurement**—An absolute measurement of the dynamic normal surface displacement of the block is required for this calibration test method. The transducer used for this measurement is a standard transducer against which the device under test is compared. The standard transducer should meet or exceed the performance of the capacitive transducer described by Breckenridge and Greenspan. When the glass capillary breaks, the force it was applying to the surface is abruptly relieved, within a time on the order of 0.2 to 0.3  $\mu\text{s}$ . Within the limitations arising from these finite dimensions, the breaking of the capillary approximates a step force function at a point on the surface of the block. Theoretical solutions for the idealized response of a half-space to a normal point-force step function in time applied to the surface are available.<sup>4,5</sup> The important characteristics of the standard transducer include high fidelity, high sensitivity, and operating characteristics amenable to theoretical calculation. It should also present no appreciable dynamic loading to the surface it is measuring.

5.3.1 For a calibration, the standard transducer and the device to be calibrated are both placed on the same surface of the block as the mechanical input and equidistant in opposite directions from it. This guarantees that both experience the same displacement-time history. Comparison of the output of the transfer standard or AE sensor with the output of the standard transducer yields a calibration of the device under test. The outputs of flat-response transducers have been found to be a good match (except for the infinite amplitude part) to the theoretical waveforms, supporting the use of this theory as a check on the primary calibration of sensors. An example with a flat response transducer is shown in Figure 9. The vertical component of the theoretical waveform comprises three parts: (a) a low-amplitude response beginning at time  $d/c_L$ , where  $d$  is the distance from the source and  $c_L$  is the longitudinal wave velocity; (b) a short impulsive response between times  $d/c_S$  and  $d/c_R$ , where  $c_S$  is the shear wave velocity and  $c_R$  the Rayleigh wave velocity; (c) a step function beginning at  $d/c_R$ . It is the last of these that is salient for checking the sensor calibration. The theoretical height<sup>6</sup> (shelf value [see Figure 9 for determination of the shelf value], relative to zero displacement) of this displacement step  $u_3$  is:

$$u_3 = F_0 A / 4\pi\mu d (A - 1) \quad \text{E1106-12}_1$$

where  $F_0$  is the applied force (which is measured),  $\mu$  is the shear modulus (calculated by use of the shear wave velocity) of the test block,  $A = (c_L/c_S)^2$  and  $d$  is the distance from the source to the transducer.

**5.3 Absolute Displacement Measurement**—An absolute measurement of the dynamic normal surface displacement of the block is required for this calibration test method. The transducer used for this measurement is a standard transducer against which the device under test is compared. The standard transducer should meet or exceed the performance of the capacitive transducer

<sup>3</sup> Breckenridge, F. R., "Acoustic Emission Transducer Calibration by Means of the Seismic Surface Pulse,"

<sup>3</sup> Burks, Brian, "Re-Examination of NIST Acoustic Emission Sensor Calibration: Part I – Modeling the Loading from Glass Capillary Fracture," *Journal of Acoustic Emission* Vol 1, pp. 87–94., Vol. 29, pp. 167–174.

<sup>4</sup> Hsu, N. N., and Breckenridge, F. R., "Characterization and Calibration of Acoustic Emission Sensors," *Materials Evaluation*, Vol 39, 1981, pp. 60–68.

<sup>4</sup> Breckenridge, F. R., "Acoustic Emission Transducer Calibration by Means of the Seismic Surface Pulse," *Journal of Acoustic Emission* Vol 1, pp. 87–94.

<sup>5</sup> Breckenridge, F. R., and Greenspan, M., "Surface-Wave Displacement: Absolute Measurements Using a Capacitive Transducer," *Journal, Acoustic Society of America*, Vol 69, pp 1177–1185.

<sup>5</sup> Hsu, N. N., and Breckenridge, F. R., "Characterization and Calibration of Acoustic Emission Sensors," *Materials Evaluation*, Vol 39, 1981, pp. 60–68.

<sup>6</sup> Paul G. Richards, "Elementary Solutions to Lamb's Problem for a Point Source and their Relevance to Three-Dimensional Studies of Spontaneous Crack Propagation," *Bull. of the Seismological Society of America*, Vol 69, No. 4, 1979, pp. 947–956.

described by Breckenridge and Greenspan.<sup>7</sup> The important characteristics of the standard transducer include high fidelity, high sensitivity, and operating characteristics amenable to theoretical calculation. It should also present no appreciable dynamic loading to the surface it is measuring.

5.3.1 For a calibration, the standard transducer and the device to be calibrated are both placed on the same surface of the block as the mechanical input and equidistant in opposite directions from it. This guarantees that both experience the same displacement-time history. Comparison of the output of the transfer standard or AE sensor with the output of the standard transducer yields a calibration of the device under test.

5.3.2 Other relative geometries for the input and transducers are possible, but results from other geometries should only be used to supplement results from the “same surface” geometry. AE waves in structures are most frequently dominated by surface wave phenomena, and the calibration should be based on the transducer’s response to such waves.

5.4 *Units for the Calibration*—An AE sensor may be considered to respond to either stress or strain at its front face. The actual stress and strain at the front face of a mounted sensor depend on the interaction between the mechanical impedance of the sensor (load) and that of the mounting block (driver). Neither the stress nor the strain is amenable to direct measurement at this location. However, the free displacement that would occur at the surface of the block in the absence of the sensor can be inferred from either elasticity theory calculations or from measurements made elsewhere on the surface. Also, the ideal displacement (except at the surface point where the displacement becomes infinite) for an ideal source is known from theory. Since AE sensors are used to monitor motion at a free surface of a structure and interactive effects between sensor and structure are generally of no interest, the free surface motion is the appropriate input variable. It is, therefore, recommended that the units of calibration should be voltage per unit of free motion; for example, volts per metre.

#### 5.5 *Block Material:*

5.5.1 Since the calibration depends on the interaction of the mechanical impedance of the block and that of the AE sensor, a calibration procedure must specify the material of the block. Calibrations performed on blocks of different materials will yield transducer sensitivity versus frequency curves that are different in shape and in average magnitude. The amount by which such averages differ may be very large. A transducer calibrated on a glass or aluminum block will have an average sensitivity that may be from 50 to 100 % of the value obtained on steel, and will have an average sensitivity that may be as little as 3 % of the value obtained on steel if calibrated on a polymethyl methacrylate block. In general, the sensitivity will be less if the block is made of a less rigid or less dense material.

5.5.2 The Rayleigh speed in the material of the block affects surface wave calibrations. For a sensor having a circular aperture (mounting face) with uniform sensitivity over the face, the aperture effect predicts nulls at the zeroes of  $J_1(ka)$ , where  $k=2\pi f/c_R$ ,  $k = 2\pi f/c_R$ , and  $f$  = frequency,  $c_R$  = Rayleigh speed, and  $a$  = radius of the sensor face (active element). Hence, the frequencies at which the nulls occur are dependent upon the Rayleigh speed.

## 6. Apparatus

6.1 A typical basic scheme for the calibration is shown in Fig. 1. A glass capillary, *B*, of diameter about 0.2 mm, is squeezed between the tip of the loading screw, *C*, and the upper face of the large steel transfer block, *A*. When the capillary breaks, the sudden release of force is nearly a step function whose risetime is of the order of  $0.1$ – $0.2$   $\mu$ s to  $0.3$   $\mu$ s. The magnitude of the force step is measured by the combination of the PZT disc, *D*, in the loading screw and a charge amplifier, *E*, connected to a storage oscilloscope, connected to a waveform recorder, *F*. The standard capacitive transducer, *G*, and the device under test, *H*, are placed equally distant (usually 100 mm) from the source and in opposite directions from it. It is obvious from the symmetry that the surface displacements would be the same at the two transducer locations if it were not for the loading effects of the transducers. The loading effect of the standard capacitive transducer is negligible and the loading effect of the unknown sensor is part of its calibration.

6.1.1 Voltage transients from the two transducers are recorded simultaneously by digital recorders, *I*, and the information is stored for processing by the computer, *J*.

6.1.2 With such a system, it is possible to do the necessary comparison between the signal from the unknown sensor and that from the standard transducer or with the displacement waveform calculated by elasticity theory. A similar result should be obtained either way.

6.1.2 With such a system, it is possible to do the necessary comparison between the signal from the unknown sensor and that from the standard transducer.

6.1.3 As a check, the shelf value (see section 5.2.1) determined from the standard transducer output is compared with the value determined from the measured capillary break force using the equation in 5.2.1. This comparison should provide supporting evidence that the precision stated in 8.5 has been attained. This check should be made at least one time for each calibration performed.

6.2 *The Transfer Block*—The transfer block must be made from specially chosen material. It should be as defect-free as possible and should undergo an ultrasonic longitudinal examination at 2.25 MHz. The method described in Practice E114 should be used.

<sup>7</sup> Breckenridge, F. R., and Greenspan, M., “Surface-Wave Displacement: Absolute Measurements Using a Capacitive Transducer,” *Journal, Acoustic Society of America*, Vol 69, pp 1177–1185.

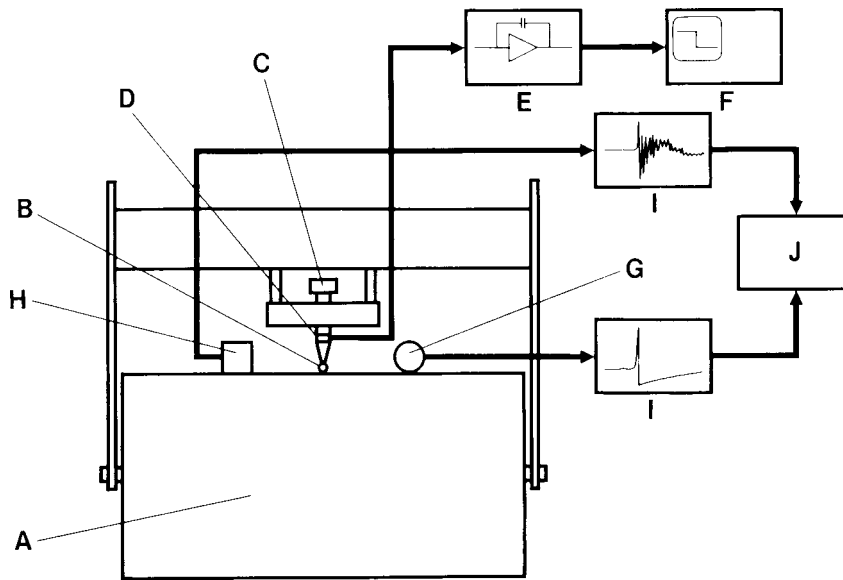

- A—steel transfer block
- B—capillary source
- C—loading screw
- D—PZT disc
- D—PZT disc or strain-gage load cell
- E—charge amplifier
- E—charge amplifier or strain gage conditioning electronics
- F—storage oscilloscope
- F—transient recorder
- G—standard transducer
- H—transducer under test
- I—transient recorder
- J—computer

FIG. 1 Schematic Diagram of the Apparatus

The block should contain no flaws which give a reflection larger than 10 % of the first back wall reflection. The material should also be highly uniform as determined by pulse-echo time of flight measurements through the block at a minimum of 15 locations regularly spaced over the surface (see Practice E494). The individual values of the longitudinal and shear wave speed should differ from the average by no more than  $\pm 1$  part and  $\pm 3$  parts in  $10^4$ , respectively. A transfer block and calibration apparatus is shown in Fig. 2.

~~6.3 The Step Function Source—The step function force events are to be made by breaking glass capillary tubing (~~

6.3 The Source—The source events, which are a useful approximation to force step functions, are to be made by breaking glass capillary tubing (Fig. 3). The capillaries are drawn down from ordinary laboratory glass tubing made of borosilicate glass. Sizes of the capillary may range from about 0.1 mm to 0.3 mm outside diameter, with 0.2 mm being typical. A bore size equal to the wall thickness gives the best results. The force obtained is usually between 10 N and 30 N, with 20 N being typical. N.

6.3.1 The capillary is to be laid horizontally (perpendicular to the propagation direction to the transducers) on a piece of microscope cover glass (0.08 mm by 1.5 mm by 1.5 mm) which has been cemented to the top face of the steel block with salol (phenyl salicylate) or cyanoacrylate cement. The force is applied to the capillary by a solid glass rod (2 mm in diameter) which has been laid horizontally on top of the capillary and at right angles to it. The rod is forced downward by the loading screw until the capillary breaks. The loading screw is to be threaded through a yoke above the calibration surface. The loading screw should contain a ceramic force transducer or a strain-gage based load cell, which has been calibrated by dead weights. Thus, although the size of a source event cannot be predicted in advance, its magnitude may be measured and used for the elasticity theory calculation of the surface displacement as given in section 5.2.1.

6.3.2 Ideally, the capillary should rest directly on the steel with no cover glass interposed. It may be found necessary to use the cover slide to prevent damage to the block surface. The presence of the cover glass does alter the waveform very slightly; a slight ringing occurs due to reflections at its boundaries. The ringing contains only frequencies above 2 MHz. Furthermore, the effects on both standard transducer and unknown sensor are the same; therefore, the calibration is not affected.

6.4 The Standard Transducer—The standard transducer to be used for the absolute measurement of displacement in the calibration is to have characteristics at least as good as the capacitive transducer described by Breckenridge and Greenspan.<sup>7</sup> This device, shown in Figs. 4 and 5, essentially consists of an inertial mass (about 40 g) mounted on compliant supports and separated from the top surface of the steel block by an air gap of about 4  $\mu$ m. This gap is determined by measuring the capacitance between the transducer and the transfer block using a three-terminal ratio arm bridge as described by Breckenridge and Greenspan<sup>7</sup> or an

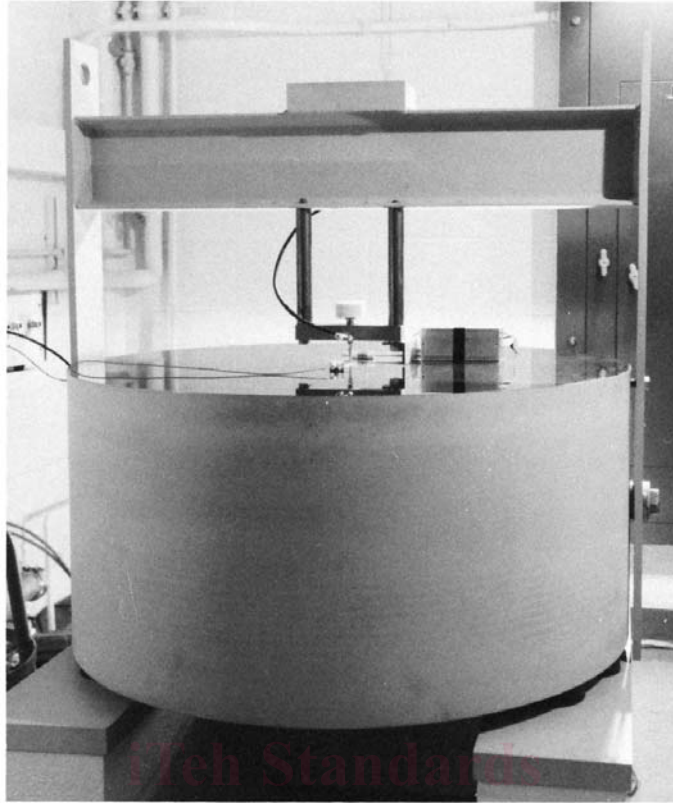

FIG. 2 Photograph of the Steel Block with the Calibration Apparatus in Place

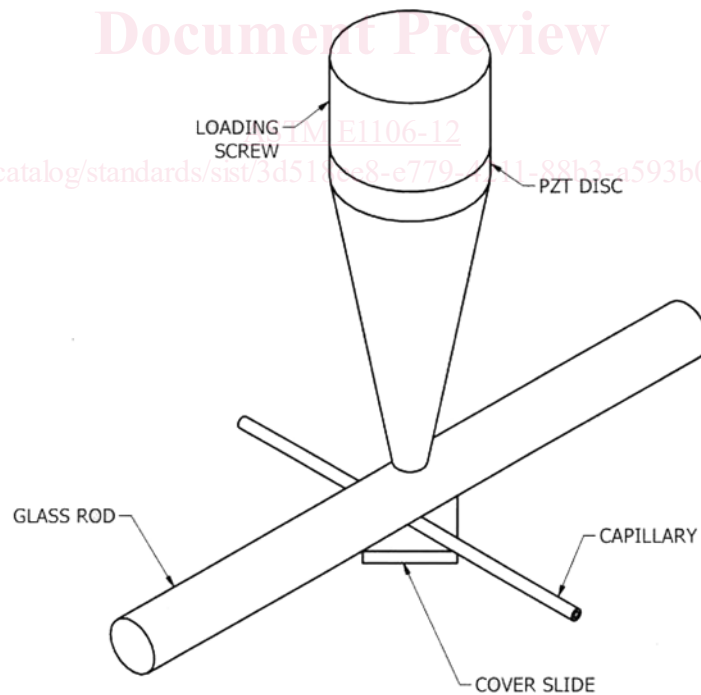

FIG. 3 Glass Capillary Source

alternate technique with similar accuracy. The inertial mass is a brass cylinder with its axis horizontal. When the block surface moves at frequencies above the natural resonance of the mass on its compliant supports (approximately 1 kHz), the brass cylinder remains approximately stationary. The brass cylinder is polarized to 100.00 Vdc through a large valued resistor. The large resistance causes the capacitor to operate essentially in a fixed charge condition so that the voltage varies inversely with capacitance for the frequencies of interest.

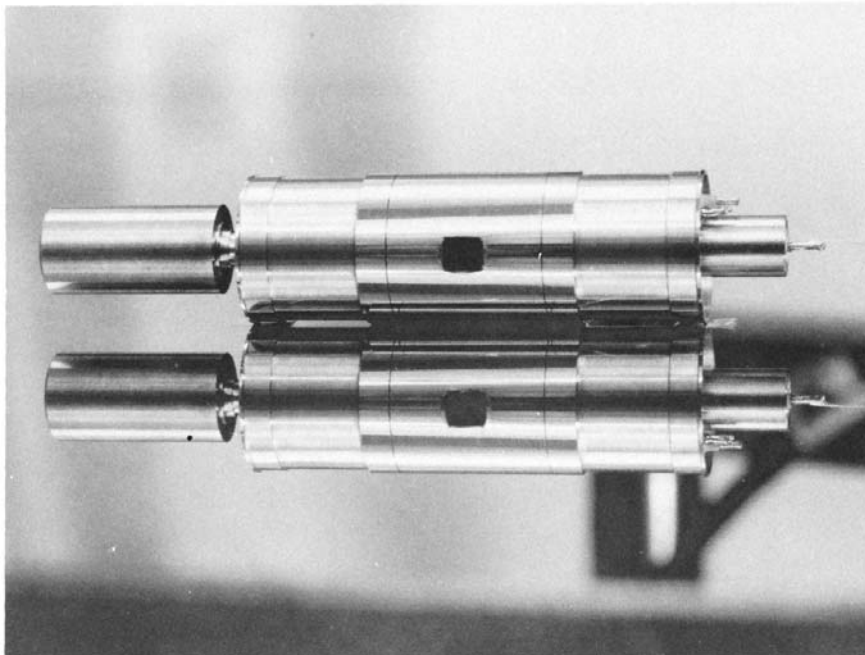
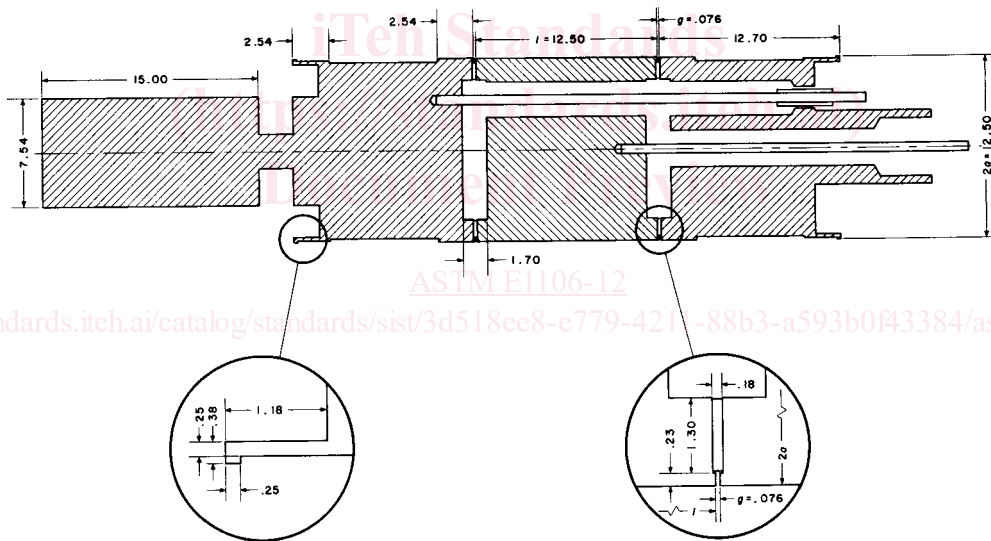

FIG. 4 Photograph of the Capacitive Transducer and its Reflection in the Steel Block



NOTE 1—All dimensions are given in millimetres. Here  $l$  is the length of the active electrode,  $2a$  is its diameter, and  $g$  is the width of the guard gap.

FIG. 5 Longitudinal Section Through the Transducer

6.4.1 For use as a primary standard, it is essential that the sensitivity of the transducer be calculable. To make the calculations tractable, the cylinder is treated as a section of an infinite cylinder. Electrical guards are attached to each end to eliminate end effects that would otherwise be severe.

6.4.2 The sensing area of the transducer is 12.4 mm long and effectively less than 1 mm wide. The long axis of this area is tangent to an advancing wavefront from the capillary source.

6.4.3 The sensitivity of the transducer is approximately  $12 \times 10^6$  V/m and the minimum detectable rms displacement is  $4 \times 10^{-12}$  m. The calculated frequency response of the transducer based on its effective aperture width and its deviation from the curvature of the wavefronts is shown in Fig. 6. At 1 MHz the amplitude is down by less than 10 % and the phase lag is about  $8^\circ$ . Expressions in Breckenridge and Greenspan<sup>7</sup> can be used to calculate the response at frequencies of interest. The total estimated uncertainty in the displacement measurements is approximately  $\pm 5$  %. Displacement measurements made by the transducer are in agreement with displacements calculated by elasticity theory within 5 %. See Breckenridge and Greenspan.<sup>7</sup>

6.4.4 The standard transducer and the device under test are to be placed  $100 \pm 1$  mm from the source unless otherwise stated in each report of calibration results.