



Designation: E606/E606M – 12

Standard Test Method for Strain-Controlled Fatigue Testing¹

This standard is issued under the fixed designation E606/E606M; the number immediately following the designation indicates the year of original adoption or, in the case of revision, the year of last revision. A number in parentheses indicates the year of last reapproval. A superscript epsilon (ϵ) indicates an editorial change since the last revision or reapproval.

1. Scope

1.1 This test method covers the determination of fatigue properties of nominally homogeneous materials by the use of test specimens subjected to uniaxial forces. It is intended as a guide for fatigue testing performed in support of such activities as materials research and development, mechanical design, process and quality control, product performance, and failure analysis. While this test method is intended primarily for strain-controlled fatigue testing, some sections may provide useful information for force-controlled or stress-controlled testing.

1.2 The use of this test method is limited to specimens and does not cover testing of full-scale components, structures, or consumer products.

1.3 This test method is applicable to temperatures and strain rates for which the magnitudes of time-dependent inelastic strains are on the same order or less than the magnitudes of time-independent inelastic strains. No restrictions are placed on environmental factors such as temperature, pressure, humidity, medium, and others, provided they are controlled throughout the test, do not cause loss of or change in dimension with time, and are detailed in the data report.

NOTE 1—The term *inelastic* is used herein to refer to all nonelastic strains. The term *plastic* is used herein to refer only to the time-independent (that is, noncreep) component of inelastic strain. To truly determine a time-independent strain the force would have to be applied instantaneously, which is not possible. A useful engineering estimate of time-independent strain can be obtained when the strain rate exceeds some value. For example, a strain rate of $1 \times 10^{-3} \text{ sec}^{-1}$ is often used for this purpose. This value should increase with increasing test temperature.

1.4 This test method is restricted to the testing of uniform gage section test specimens subjected to axial forces as shown in Fig. 1(a). Testing is limited to strain-controlled cycling. The test method may be applied to hourglass specimens, see Fig. 1(b), but the user is cautioned about uncertainties in data analysis and interpretation. Testing is done primarily under constant amplitude cycling and may contain interspersed hold

times at repeated intervals. The test method may be adapted to guide testing for more general cases where strain or temperature may vary according to application specific histories. Data analysis may not follow this test method in such cases.

1.5 The values stated in either SI units or inch-pound units are to be regarded separately as standard. The values stated in each system may not be exact equivalents; therefore, each system shall be used independently of the other. Combining values from the two systems may result in non-conformance with the standard.

2. Referenced Documents

2.1 ASTM Standards:²

- A370 Test Methods and Definitions for Mechanical Testing of Steel Products
- E3 Guide for Preparation of Metallographic Specimens
- E4 Practices for Force Verification of Testing Machines
- E8/E8M Test Methods for Tension Testing of Metallic Materials
- E9 Test Methods of Compression Testing of Metallic Materials at Room Temperature
- E83 Practice for Verification and Classification of Extensometer Systems
- E111 Test Method for Young's Modulus, Tangent Modulus, and Chord Modulus
- E112 Test Methods for Determining Average Grain Size
- E132 Test Method for Poisson's Ratio at Room Temperature
- E177 Practice for Use of the Terms Precision and Bias in ASTM Test Methods
- E209 Practice for Compression Tests of Metallic Materials at Elevated Temperatures with Conventional or Rapid Heating Rates and Strain Rates
- E337 Test Method for Measuring Humidity with a Psychrometer (the Measurement of Wet- and Dry-Bulb Temperatures)
- E384 Test Method for Knoop and Vickers Hardness of Materials
- E399 Test Method for Linear-Elastic Plane-Strain Fracture Toughness K_{Ic} of Metallic Materials

¹ This test method is under the jurisdiction of ASTM Committee E08 on Fatigue and Fracture and is the direct responsibility of Subcommittee E08.05 on Cyclic Deformation and Fatigue Crack Formation.

Current edition approved June 1, 2012. Published September 2012. Originally approved in 1977. Last previous edition approved in 2004 as E606 – 92(2004) ϵ^1 . DOI: 10.1520/E0606-04E01.

² For referenced ASTM standards, visit the ASTM website, www.astm.org, or contact ASTM Customer Service at service@astm.org. For *Annual Book of ASTM Standards* volume information, refer to the standard's Document Summary page on the ASTM website.

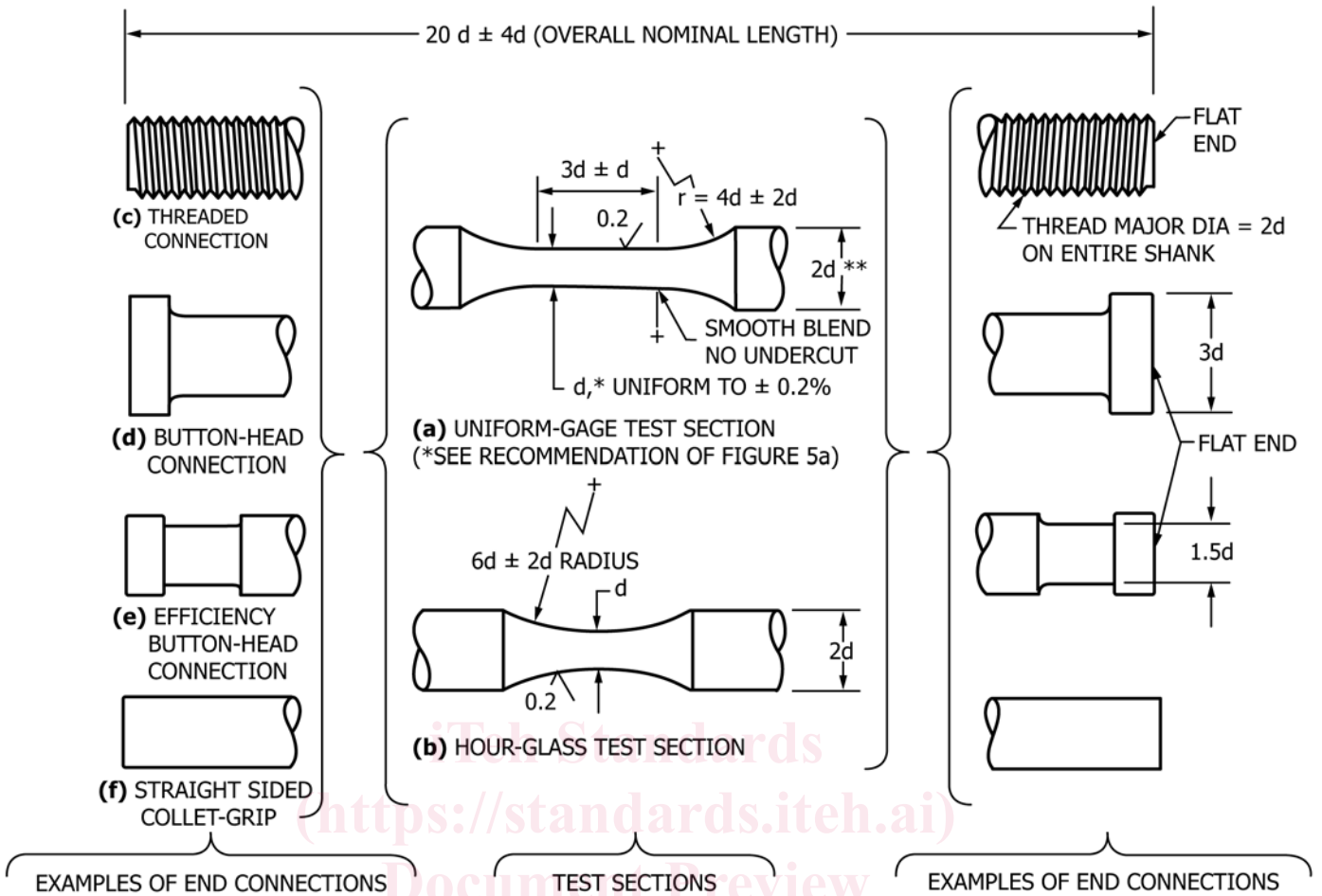

NOTE 1—* Dimension d is recommended to be 6.35 mm (0.25 in.). See 7.1. Centers permissible. ** This diameter may be made greater or less than $2d$ depending on material hardness. In typically ductile materials diameters less than $2d$ are often employed and in typically brittle materials diameters greater than $2d$ may be found desirable.

NOTE 2—Threaded connections are more prone to inferior axial alignment and have greater potential for backlash, particularly if the connection with the grip is not properly designed.

FIG. 1 Recommended Low-Cycle Fatigue Specimens

- E466 Practice for Conducting Force Controlled Constant Amplitude Axial Fatigue Tests of Metallic Materials
- E467 Practice for Verification of Constant Amplitude Dynamic Forces in an Axial Fatigue Testing System
- E468 Practice for Presentation of Constant Amplitude Fatigue Test Results for Metallic Materials
- E691 Practice for Conducting an Interlaboratory Study to Determine the Precision of a Test Method
- E739 Practice for Statistical Analysis of Linear or Linearized Stress-Life ($S-N$) and Strain-Life ($\epsilon-N$) Fatigue Data
- E1012 Practice for Verification of Testing Frame and Specimen Alignment Under Tensile and Compressive Axial Force Application
- E1049 Practices for Cycle Counting in Fatigue Analysis
- E1245 Practice for Determining the Inclusion or Second-Phase Constituent Content of Metals by Automatic Image Analysis
- E1823 Terminology Relating to Fatigue and Fracture Testing

3. Terminology

3.1 The definitions in this test method are in accordance with Terminology E1823.

3.2 *Definitions:* Additional definitions associated with time-dependent deformation behavior observed in tests at elevated homologous temperatures are as follows:

3.2.1 *hold period, τ_h* —, the time interval within a cycle during which the stress or strain is held constant.

3.2.2 *inelastic strain, ϵ_{in}* —, the strain that is not elastic.

3.2.2.1 *Discussion*—For isothermal conditions, ϵ_{in} is calculated by subtracting the elastic strain from the total strain.

3.2.3 *total cycle period, τ_t* —the time for the completion of one cycle. The parameter τ_t can be separated into hold and non-hold (that is, steady and dynamic) components:

$$\tau_t = \sum \tau_h + \sum \tau_{nh} \quad (1)$$

where:

$\sum \tau_h$ = sum of all the hold portions of the cycle and
 $\sum \tau_{nh}$ = sum of all the nonhold portions of the cycle.

τ_t also is equal to the reciprocal of the overall frequency when the frequency is held constant.

The following equations are often used to define the instantaneous stress and strain relationships for many metals and alloys:

$$\varepsilon = \varepsilon_{in} + \varepsilon_e \quad (2)$$

$$\varepsilon_e = \frac{\sigma}{E^*} \text{ (see Note 2)}$$

and the change in strain from any point (1) to any other point (3), as illustrated in Fig. 2, can be calculated as follows:

$$\varepsilon_3 - \varepsilon_1 = \left(\varepsilon_{3in} + \frac{\sigma_3}{E^*} \right) - \left(\varepsilon_{1in} + \frac{\sigma_1}{E^*} \right) \quad (3)$$

All strain points to the right of and all stress points above the origin are positive. The equation would then show an increase in inelastic strain from 1 to 3 or:

$$\varepsilon_{3in} - \varepsilon_{1in} = \varepsilon_3 - \varepsilon_1 + \frac{\sigma_1}{E^*} - \frac{\sigma_3}{E^*} \quad (4)$$

Similarly, during the strain hold period, the change in the inelastic strain will be equal to the change in the stress divided by E^* , or:

$$\varepsilon_{3in} - \varepsilon_{2in} = \frac{\sigma_2 - \sigma_3}{E^*} \quad (5)$$

NOTE 2— E^* represents a material parameter that may be a function of environment and test conditions. It also may vary during a test as a result of metallurgical or physical changes in the specimen. In many instances, however, E^* is practically a constant quantity and is used rather extensively in isothermal, constant-rate testing, in the analysis of hysteresis loops. In such cases, a value for E^* can best be determined by cycling the

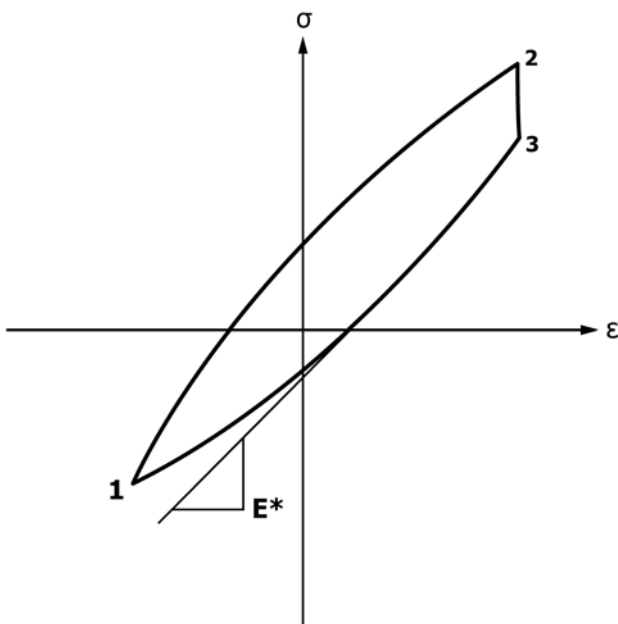

FIG. 2 Analyses of a Total Strain versus Stress Hysteresis Loop Containing a Hold Period

specimen prior to the test at stress or strain levels below the elastic limit. E^* is NOT the monotonic Young's modulus.

4. Significance and Use

4.1 Strain-controlled fatigue is a phenomenon that is influenced by the same variables that influence force-controlled fatigue. The nature of strain-controlled fatigue imposes distinctive requirements on fatigue testing methods. In particular, cyclic total strain should be measured and cyclic plastic strain should be determined. Furthermore, either of these strains typically is used to establish cyclic limits; total strain usually is controlled throughout the cycle. The uniqueness of this test method and the results it yields are the determination of cyclic stresses and strains at any time during the tests. Differences in strain histories other than constant-amplitude alter fatigue life as compared with the constant amplitude results (for example, periodic overstrains and block or spectrum histories). Likewise, the presence of nonzero mean strains and varying environmental conditions may alter fatigue life as compared with the constant-amplitude, fully reversed fatigue tests. Care must be exercised in analyzing and interpreting data for such cases. In the case of variable amplitude or spectrum strain histories, cycle counting can be performed with Practice E1049.

4.2 Strain-controlled fatigue can be an important consideration in the design of industrial products. It is important for situations in which components or portions of components undergo either mechanically or thermally induced cyclic plastic strains that cause failure within relatively few (that is, approximately $<10^5$) cycles. Information obtained from strain-controlled fatigue testing may be an important element in the establishment of design criteria to protect against component failure by fatigue.

4.3 Strain-controlled fatigue test results are useful in the areas of mechanical design as well as materials research and development, process and quality control, product performance, and failure analysis. Results of a strain-controlled fatigue test program may be used in the formulation of empirical relationships between the cyclic variables of stress, total strain, plastic strain, and fatigue life. They are commonly used in data correlations such as curves of cyclic stress or strain versus life and cyclic stress versus cyclic plastic strain obtained from hysteresis loops at some fraction (often half) of material life. Examination of the cyclic stress-strain curve and its comparison with monotonic stress-strain curves gives useful information regarding the cyclic stability of a material, for example, whether the values of hardness, yield strength, ultimate strength, strain-hardening exponent, and strength coefficient will increase, decrease, or remain unchanged (that is, whether a material will harden, soften, or be stable) because of cyclic plastic straining (1).³ The presence of time-dependent inelastic strains during elevated temperature testing provides the opportunity to study the effects of these strains on fatigue life and on the cyclic stress-strain response of the material. Information about strain rate effects, relaxation behavior, and

³ The boldface numbers in parentheses refer to the list of references at the end of this standard.

creep also may be available from these tests. Results of the uniaxial tests on specimens of simple geometry can be applied to the design of components with notches or other complex shapes, provided that the strains can be determined and multiaxial states of stress or strain and their gradients are correctly correlated with the uniaxial strain data.

5. Functional Relationships

5.1 Empirical relationships that have been commonly used for description of strain-controlled fatigue data are given in [Appendix X1](#). These relationships may not be valid when large time-dependent inelastic strains occur. For this reason original data should be reported to the greatest extent possible. Data reduction methods should be detailed along with assumptions. Sufficient information should be developed and reported to permit analysis, interpretation, and comparison with results for other materials analyzed using currently popular methods.

5.2 If use is made of hourglass geometries, original data should be reported along with results analyzed using the relationships in [Appendix X2](#).

6. Methodology

6.1 *Testing Machine*—Testing should be conducted with a tension-compression fatigue testing machine that has been verified in accordance with Practices [E4](#) and [E467](#), unless more stringent requirements are called for in this specification. The testing machine, together with any fixtures used in the test program, must meet the bending strain criteria in [6.3.1](#). The machine should be one in which specific measures have been taken to minimize backlash in the loading train.

NOTE 3—Force measuring capability of 45 kN [approximately 10 kips] or greater would be sufficient for the recommended specimens (Section 7) and most test materials. The machine force capacity used for these specimens would not be required to exceed 110 kN [approximately 25 kips]; however, large-capacity fatigue machines may be beneficial because of increased axial stiffness and decreased lateral deflection of these systems. Achieving a change in axial concentricity of less than or equal to 0.05 mm [0.002 in.] TIR (total indicator reading), as measured between the top and bottom specimen fixture under cyclic force, is a measure of success with respect to minimizing lateral deflection of the loading train.

6.2 *Strain Control*—Testing machine controls should permit cycling between constant strain limits. If material behavior permits (for example, aging effects do not hinder), control stability should be such that the strain maximum and minimum limits are repeatable over the test duration to within 1 % of the range between maximum and minimum control limits.

NOTE 4—See [6.4.1](#) and [6.5](#) on use of force and strain transducers in relation to repeatability requirements.

NOTE 5—For strain control under long-life conditions it is sometimes advantageous to run a pseudostrain control test under force control. The test could be started in strain control and switched to force control after cyclic stabilization of the stress response occurs. In these cases strain should be monitored (directly or indirectly) and adjustments made in force control to maintain strain limits within 1 % of the range between maximum and minimum limits. Practice [E466](#) provides additional details on force controlled axial fatigue testing.

6.3 Fixtures:

6.3.1 To minimize bending strains, specimen fixtures should be aligned such that the major axis of the specimen closely coincides with the force axis throughout each cycle. It is

important that the accuracy of alignment be kept consistent from specimen to specimen. Accuracy and repeatability of alignment are functions of the load frame alignment and specimen-to-specimen geometric variability. Alignment shall be checked by means of a trial test specimen with longitudinal strain gages placed at four equidistant locations around the minimum diameter. The trial test specimen shall be turned about its axis, installed, and checked for each of four orientations within the fixtures. The maximum bending strains so determined shall not exceed 5 % of the minimum axial strain range imposed during any test program. For specimens having a uniform gage length, it is advisable to place a similar set of gages at two or three axial positions within the gage section. One set of strain gages should be placed at the center of the gage length to detect misalignment that causes relative rotation of the specimen ends about axes perpendicular to the specimen axis. An additional set of gages should be placed away from the gage-length center to detect relative lateral displacement of the specimen ends. The lower the bending strain, the more repeatable the test results will be from specimen to specimen. This is especially important for materials with low ductility where much better alignment may be needed.

NOTE 6—This section refers to Practice [E1012](#) Type A tests.

NOTE 7—Four strain measurements, 90° opposed to each other, are required to ensure that bending strains are not large. Utilization of a single extensometer with dual axial outputs will allow for only two specimen loadings to gather the required four strain readings, without the necessity of strain gaging specimens.

6.3.2 Several commonly used fixturing techniques are shown schematically in [Fig. 3](#). The selection of any one fixturing technique depends primarily upon the user's specimen design. Fixtures should be constructed of hardened steel for high strength and abrasion resistance. The collet type grip shown, or another fixturing technique that provides high precision lateral stiffness to hold precise alignment is acceptable. Fixtures not capable of high alignment may be coupled with the Field's metal pot ([2, 3](#)) of [Fig. 4](#) or a similar device. Such a device may help to compensate for misalignment in the loading train that would induce bending strains in the specimen during fixturing. Placement of the fixtures within die-set or flex bars reduces relative lateral motion of specimen ends and increases lateral stiffness that is important in machines that do not provide adequate safeguards against compressive buckling of the test specimen.

6.3.3 For elevated-temperature testing it is usually necessary to provide some means for cooling the fixtures to prevent damage to other loading-train components such as force transducers. One method commonly used employs water-cooling coils attached to the fixtures or to other appropriate locations in the loading train. Care must be taken to avoid affecting the force transducer calibration or the loading-train alignment by the addition of cooling coils.

6.4 *Extensometers*—Extensometers should be employed for the purpose of measuring deformation in the gage section. They should be suitable for dynamic measurements over long periods of time.

6.4.1 The non-self contained extensometer may be of two major types: Contacting (for example, the more frequently

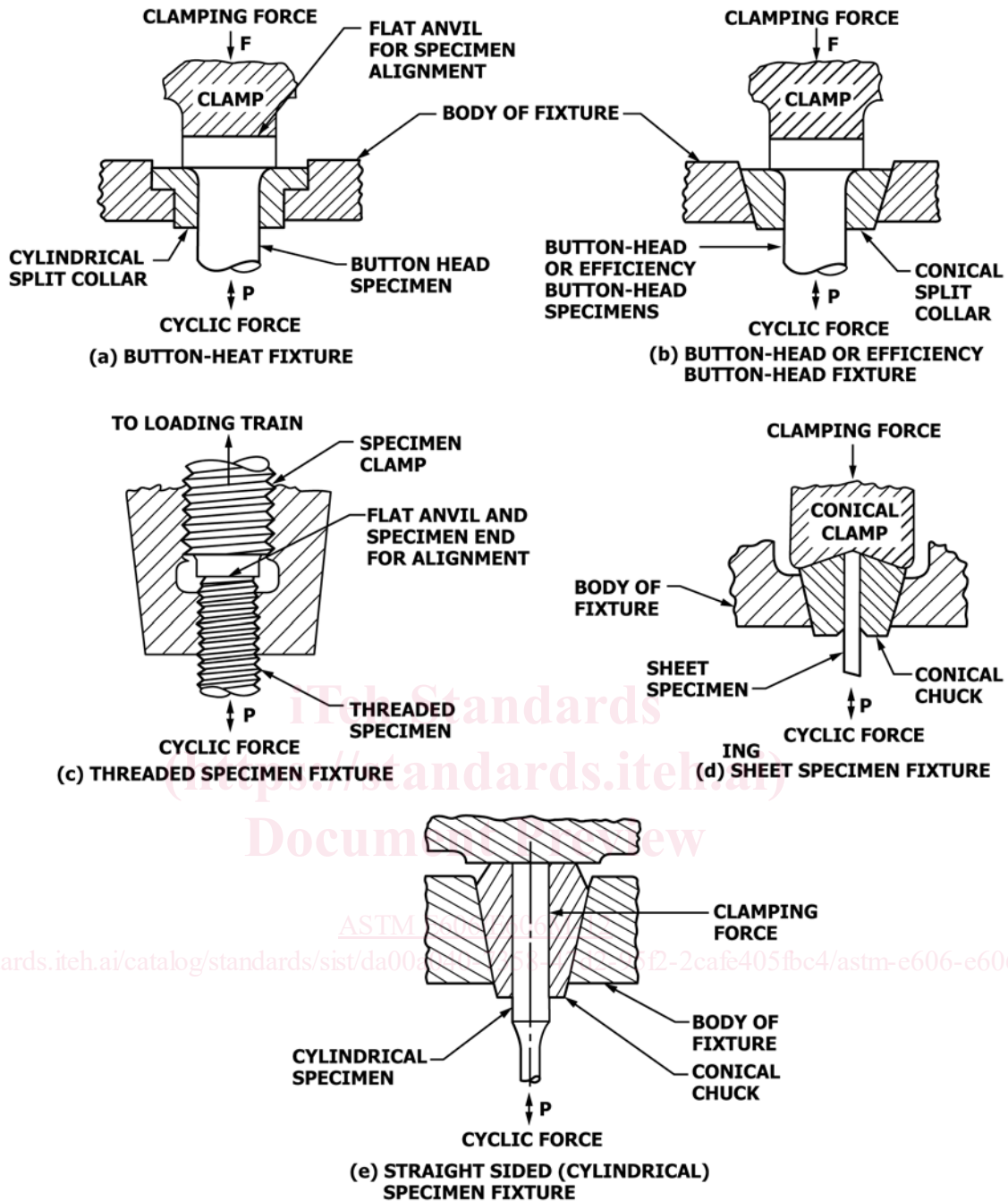

NOTE 1—The clamping force should be greater than the cyclic force to avoid backlash within the specimen fixture.

FIG. 3 Schematic Examples of Fixturing Techniques For Various Specimen Designs

used strain gage or LVDT type as shown in Fig. 5) or noncontacting (for example, optical types). The output of the extensometer or auxiliary device of the extensometer system should be suitable for control purposes, readout, and recording. The extensometers should qualify as Class B-2 or better in accordance with Practice E83.

NOTE 8—For best results, the extensometer system (mechanical and electrical) should have a maximum nonlinearity of 0.3 % of full-scale range. Thus, the extensometer design should minimize sources of mechanical hysteresis. The more effective designs have a low activation force that eliminates slippage of the contacts and a low mass to provide high natural frequency for improved dynamic response characteristics.

6.4.2 Extensometers should measure longitudinal deformation when a uniform-gage specimen, such as shown in Fig. 1(a), is tested. Generally, these extensometers are attached as shown in Fig. 5(a).

NOTE 9—Care should be exercised when installing the longitudinal extensometer so as to prevent damage to the specimen surface and consequential premature fatigue failure at the contact points. It is very important to ensure a secure attachment of the extensometer to the test specimen. Damaged or worn contacts or flexure in the attachment apparatus can induce significant hysteresis errors in the measurement. Often, small strips of transparent tape, copper bondable strain gage terminals, or other such protective tabs are adhered to the specimen's

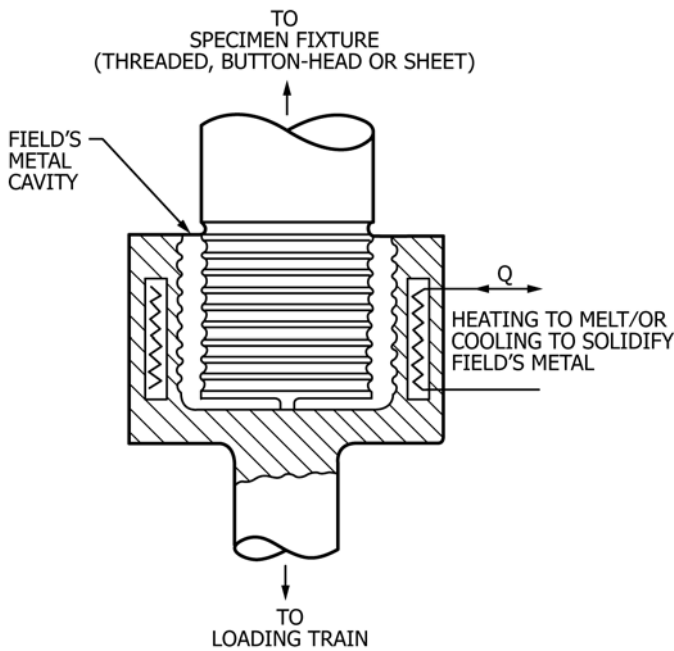

NOTE 1—Field's metal pot is used to provide initially zero stress in the specimen during fixturing. This pot may be within a die-set to combine zero fixturing stress with rigid alignment. Field's metal is a non-toxic alternative to Wood's metal, which was referred to in earlier versions of this standard.

FIG. 4 Schematic of Field's Metal Pot Showing Principle of Operation

uniform section at the locations where extensometer tips would contact the material. Use of the tape or tabs tends to "cushion" the attachment. Another alternative is the use of quick-drying epoxy. Light force springs or small rubber bands are often employed to hold the extensometer to the specimen. Dulling the tips for softer material is also commonly done. Extensometer slippage can be observed after the first several cycles from X-Y traces or strip chart recordings by observing the stress-strain response. Unusual shifts in mean values of stress in response to imposed strain ranges are an indication of such slippage.

6.4.3 Extensometers should measure diametral deformations when specimens having hourglass profiles are tested. A typical method of diametral displacement measurement is shown schematically in Fig. 5(b). Curved extensometer tips, convex in the longitudinal plane, can provide point contact during testing. Care should be exercised during installation of the diametral extensometer to prevent damage to the test specimen surface. Extensometer tips should be adjusted properly to minimize the force they impose on the specimen. When installing the extensometer, gently move its tip longitudinally along the specimen while watching the gage readout to find the minimum diameter. Calibration of extensometers should be conducted before and after each test program.

NOTE 10—Care should be taken in the measurement of diametral strains for materials such as cast materials that possess large grains or a large degree of preferred orientation. These, as well as hexagonal close-packed materials, tend to be anisotropic and therefore may require special methods of strain measurement and interpretation because Poisson's ratio changes substantially with the orientation of the extensometer with respect to the crystallographic orientation of the specimen. Cyclic hardening or softening also might alter the apparent value of Poisson's ratio, thereby complicating data analyses and interpretation.

6.5 Force Transducers—A force transducer should be placed in series with the test specimen for the purpose of measuring magnitude and sense of the axial force transmitted through the specimen. Force transducer capacity should be selected to adequately cover the range of forces to be measured in the test being conducted, but not so large as to render larger errors (that is, greater than 1 % of the difference between maximum and minimum control limits). Force transducer calibration should be verified in accordance with Practices E4 and E467.

NOTE 11—The force transducer should be designed specifically for fatigue testing and possess the following characteristics: high resistance to bending; high axial stiffness; high linearity; accuracy and sensitivity; low hysteresis; high overturning moment stiffness; and high lateral stiffness. For best results, it is recommended that the maximum force transducer nonlinearity and hysteresis should not exceed 0.5 % and 0.3 % of full-scale range, respectively.

6.6 Data Recording Systems—Analog strip chart and X-Y recorders or their digital equivalent should be considered a minimum requirement for data collection.

NOTE 12—Accuracy of recording systems should be kept within 1 % of full scale. Analog/digital devices are available that include maximum and minimum limit detection, maximum-minimum memory, and underpeak detection.

NOTE 13—Data acquisition system characteristics such as sampling frequency and data skew between force and deformation (stress and strain) channels can affect hysteresis loop presentation on an X-Y recorder used in digital recording systems. It is recommended that these characteristics be taken into consideration along with the strain rate or frequency of cycling to determine that the hysteresis plots are within the required error limits.

6.6.1 X-Y Recording—Some means of X-Y recording should be used for the purpose of recording hysteresis loops of force versus deformation or stress versus strain. A potentiometric X-Y recorder or an oscilloscope equipped with a camera or data storage capability is an acceptable alternative. The potentiometric X-Y recorder should be used only when the rate of cycling results in a pen velocity that is less than one-half of the recorder's slewing speed. At higher frequencies, the oscilloscope may be used. Alternative devices include: digital X-Y plotters for real time recording or to plot stored data and data logging devices that store data in a host computer system or transmit data to a printer.

6.6.2 If digital-type recording devices are used, it is recommended that a sufficient number of simultaneous data pairs (such as stress and strain) be taken for both the ascending segment and descending segment of the hysteresis loop to adequately determine the shape of the loop.

6.6.3 Strip Chart Recording—Strip chart recorders may be used to monitor force (or strain). If used, the frequency of the test should be such that the recording pen velocity never exceeds one-half of the recorder's slewing speed. It is recommended that these recorders be calibrated at the testing frequencies used. Storage oscilloscopes also may be used to record the force versus strain loops. Force or strain peaks also may be monitored by devices that detect, display, and retain maximums and minimums in memory or that reproduce these data at predetermined periods.

6.7 Cycle Counter—A cycle counter shall be used to indicate total accumulated cycles of loading or straining. An