INTERNATIONAL STANDARD 3049

INTERNATIONAL ORGANIZATION FOR STANDARDIZATION • МЕЖДУНАРОДНАЯ ОРГАНИЗАЦИЯ ПО СТАНДАРТИЗАЦИИ • ORGANISATION INTERNATIONALE DE NORMALISATION

Gypsum plasters — Determination of physical properties of powder

Plâtres — Détermination des caractéristiques physiques du produit en poudre

iTeh STANDARD PREVIEW

First edition — 1974-07-01

(standards.iteh.ai)

[ISO 3049:1974](#)

<https://standards.iteh.ai/catalog/standards/sist/bf2cba65-0187-4424-89a7-3cd2867e338c/iso-3049-1974>



UDC 691.55/.56 : 620.1

Ref. No. ISO 3049-1974 (E)

Descriptors : gypsum plasters, powder (particles), tests, physical tests, sieve analysis, grain size analysis, density (mass/volume), measurement.

FOREWORD

ISO (the International Organization for Standardization) is a worldwide federation of national standards institutes (ISO Member Bodies). The work of developing International Standards is carried out through ISO Technical Committees. Every Member Body interested in a subject for which a Technical Committee has been set up has the right to be represented on that Committee. International organizations, governmental and non-governmental, in liaison with ISO, also take part in the work.

Draft International Standards adopted by the Technical Committees are circulated to the Member Bodies for approval before their acceptance as International Standards by the ISO Council.

International Standard ISO 3049 was drawn up by Technical Committee ISO/TC 152, *Gypsum, gypsum plasters and gypsum products*, and circulated to the Member Bodies in March 1973.

STANDARD PREVIEW
(standards.iteh.ai)

It has been approved by the Member Bodies of the following countries:

Austria	Mexico	Spain
Bulgaria	Netherlands	Sweden
France	Poland	Thailand
Germany	Portugal	Turkey
Iran	Romania	U.S.S.R.
Ireland	South Africa, Rep. of	

<https://standards.iteh.ai/catalog/standards/sist/bf2cba65-0187-4424-89a7-3cd286702010/iso-3049-1974>

The Member Bodies of the following countries expressed disapproval of the document on technical grounds :

Australia
Czechoslovakia
Italy
New Zealand
United Kingdom

Gypsum plasters – Determination of physical properties of powder

1 SCOPE AND FIELD OF APPLICATION

This International Standard specifies methods for determining certain physical properties of gypsum plasters (hereinafter referred to as "plasters") in powder form, namely :

- fineness of grinding;
- non-compacted bulk density.

NOTE – The determination of specific surface will be the subject of a separate International Standard.

2 REFERENCES

ISO 565, *Test sieves – Woven metal wire cloth and perforated plate – Nominal sizes of apertures.*

ISO 3048, *Gypsum plasters – General test conditions.*

3 PREPARATION OF TEST SAMPLE

From the laboratory sample, kept as indicated in 3.1.2 or 3.2.2 of ISO 3048, take the amount of plaster necessary for the determination of the physical properties.

Pass the plaster through a 2 mm sieve, crushing the lumps with a wooden spatula. Reject any lumps which cannot be crushed easily and the impurities remaining on the sieve. Identify and weigh these. Include this information in the test report.

4 DETERMINATION OF FINENESS OF GRINDING

The fineness of grinding is determined by manual sieving.¹⁾

4.1 Apparatus

4.1.1 Set of control sieves in phosphor-bronze or stainless steel, of 200 mm diameter with square mesh of 800 μm , 400 μm , 200 μm and 100 μm .²⁾ The nest of sieves is closed at the base by a "receiver" and at the top by a cover.

4.1.2 Balance, accurate to $\pm 0,1$ g.

4.1.3 Desiccator.

4.2 Procedure

Carry out two successive determinations on the test sample, in accordance with the following procedure.

Take from the prepared test sample (see clause 3) approximately 210 g of plaster and dry it at a temperature of 40 ± 4 °C to constant mass.³⁾

Allow the dried plaster to cool in the desiccator and weigh 100 ± 1 g to within 0,1 g.

Pass this plaster through the 800 μm sieve as follows.

Hold the sieve in one hand, slightly tilted, and shake it, allowing it to strike the other hand on each movement at a rate of approximately 125 times per minute, so that the plaster always spreads out evenly. Every 25 movements turn the sieve through 90°, give a few sharp taps against the side and recommence the shaking.

The sieving is considered finished when, between two weighings carried out at intervals of 1 min, the mass of plaster passing does not exceed 0,4 g.

Weigh the residue on the 800 μm sieve and express its mass as a percentage of the initial mass of the test portion (100 g).

Sieve the plaster which has already passed the 800 μm sieve on the 400 μm sieve, proceeding as before. During the sieving, the sieve may, from time to time, be tapped against a solid base and, this being particularly important for the final sieves, the lower surface of the sieve may be brushed from time to time to free holes which may have become blocked.

The sieving is considered finished when, between two weighings carried out at an interval of 1 min, the mass of plaster passing does not exceed 0,2 g.

Weigh the residue on the 400 μm sieve and express its mass as a percentage of the initial mass of the test portion (100 g).

1) The fineness of grinding determined by mechanical sieving will be studied later.

2) Or the nearest sizes to these (see ISO 565).

3) The mass is regarded as constant when the difference between the results of two successive weighings, separated by 1 h of effective drying, does not exceed 0,2 g.

After blending the plaster which has passed through the 400 μm sieve, take from it a mass of 50 g.¹⁾ Sieve this on the 200 μm sieve, following the above procedure, until the mass passing is not more than 0,1 g per minute. Weigh the residue and express its mass as a percentage of the initial mass of the test portion (100 g).²⁾

Sieve through the 100 μm sieve the plaster which has passed through the 200 μm sieve, proceeding as above and until not more than 0,1 g per minute passes. Weigh the residue and express its mass as a percentage of the initial mass of the test portion (100 g).

Weigh the plaster which has passed through the 100 μm sieve and express its mass as a percentage of the initial mass of the test portion (100 g).³⁾

4.3 Expression of results

Record for each sieve (800 μm , 400 μm , 200 μm and 100 μm) the arithmetic mean of the values obtained for the two determinations.⁴⁾

For a given sieve analysis, the results of the two determinations shall not differ by more than 1/20, or by more than 0,1 g when the residues are less than 2 g.

5 DETERMINATION OF NON-COMPACTED BULK DENSITY OF THE POWDER⁵⁾

5.1 Apparatus

5.1.1 Device (see figure 1) in brass or stainless steel, consisting of a conical vessel standing on three legs and fitted at mid-height with a sieve with square mesh of 2 mm.

5.1.2 Measuring container of capacity 1 l, provided with an extension sleeve (see figure 2).

5.1.3 Spatula.

5.1.4 Straightedge.

5.1.5 Balance, accurate to ± 1 g.

5.2 Procedure

Carry out duplicate determinations with the same apparatus as follows.

Weigh the measuring container (5.1.2) without its sleeve and place it with its sleeve under the conical vessel (5.1.1).

Pour onto the sieve, in portions of 100 g, the plaster prepared according to clause 3. Make the plaster fall into the conical vessel by turning it with the spatula.

When the measuring container fitted with its extension sleeve is full, remove the sleeve and reject excess plaster by levelling the surface, using the straightedge, in line with the upper rim of the container.

Weigh the container and the plaster to the nearest gram.

5.3 Expression of results

The value of the bulk density of the powder, in grams per litre, is equal to

$$m_1 - m_0$$

where

m_1 is the mass, in grams, of the container with the plaster;

m_0 is the mass, in grams, of the container.

If the results of the two determinations differ by less than 5 %, retain the mean value as the non-compacted bulk density of the powder. If not, repeat the determination until two values are obtained which differ by less than 5 %, and retain their mean.

6 TEST REPORT

The test report shall include the following particulars :

- the reference of the method used;
- the results and the method of expression used;
- any unusual features noted during the determination;
- any operation not included in this International Standard, or regarded as optional.

1) This assumes that the mass m_1 of the plaster which has passed through the 400 μm sieve is greater than 50 g. The aim is to carry on sieving with a mass not greater than 50 g. The mass m_1 is obtained by deducting from the initial 100 g the residues on the 800 μm and 400 μm sieves.

2) If m'_2 is the mass of the residue, in grams, the percentage of the initial mass of 100 g is $m_1 m'_2 / 50$ if $m_1 > 50$, and m'_2 if $m_1 \leq 50$.

3) The result found for this percentage should not be less than one unit from the difference between the initial mass of the test portion and the sum of successive residues.

4) When sieves of sizes near to those specified in 4.1 are used, it is recommended that graphical interpolation be used in order to compare the results obtained.

5) It should be remembered that there exist three densities (or mass per unit volume) for powdery products :

- the density (absolute) of the "matter" of which the product is composed;
- the density of the particle, which takes account of voids within the particle;
- the bulk density of the powder, which takes account also of voids between particles.

Dimensions in millimetres

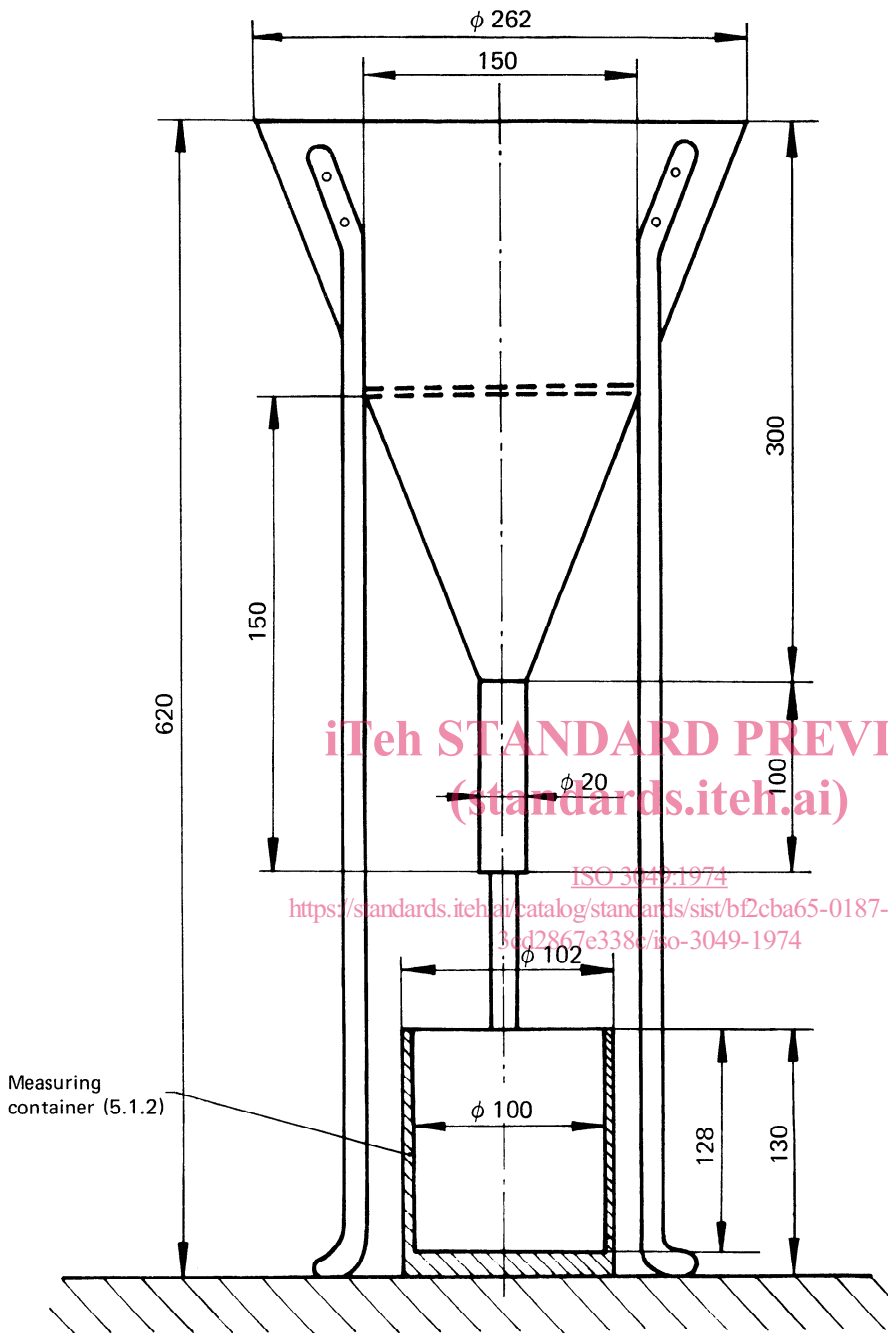

FIGURE 1 – Apparatus for determination of non-compacted bulk density

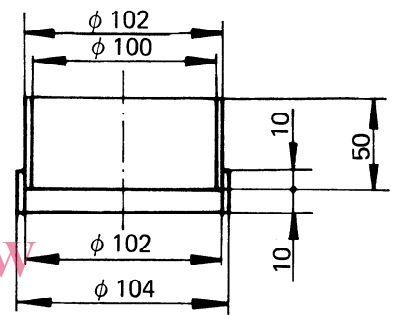

FIGURE 2 – Extension sleeve for measuring container

iTeh STANDARD PREVIEW
 (standards.iteh.ai)
 ISO 3049:1974
<https://standards.iteh.ai/catalog/standards/sist/bf2cba65-0187-4424-89a7-bd2867e3388/iso-3049-1974>

iTeh STANDARD PREVIEW
(standards.iteh.ai)

This page intentionally left blank

[ISO 3049:1974](#)

<https://standards.iteh.ai/catalog/standards/sist/bf2cba65-0187-4424-89a7-3cd2867e338c/iso-3049-1974>

iTeh STANDARD PREVIEW
(standards.iteh.ai)

This page intentionally left blank

[ISO 3049:1974](#)

<https://standards.iteh.ai/catalog/standards/sist/bf2cba65-0187-4424-89a7-3cd2867e338c/iso-3049-1974>

iTeh STANDARD PREVIEW
(standards.iteh.ai)

This page intentionally left blank

[ISO 3049:1974](#)

<https://standards.iteh.ai/catalog/standards/sist/bf2cba65-0187-4424-89a7-3cd2867e338c/iso-3049-1974>