



Designation: **A703/A703M—12 A703/A703M – 12a**

Standard Specification for Steel Castings, General Requirements, for Pressure-Containing Parts¹

This standard is issued under the fixed designation A703/A703M; the number immediately following the designation indicates the year of original adoption or, in the case of revision, the year of last revision. A number in parentheses indicates the year of last reapproval. A superscript epsilon (ϵ) indicates an editorial change since the last revision or reapproval.

This standard has been approved for use by agencies of the Department of Defense.

1. Scope*

1.1 This specification² covers a group of common requirements that, unless otherwise specified in an individual specification, shall apply to steel castings for pressure-containing parts under each of the following ASTM specifications:

Title of Specification	ASTM Designation
Steel Castings, Carbon, Suitable for Fusion Welding, for High-Temperature Service	A216/A216M
Steel Castings, Martensitic Stainless and Alloy, for Pressure-Containing Parts, Suitable for High-Temperature Service	A217/A217M
Castings, Austenitic, Austenitic-Ferritic (Duplex), Pressure-Containing Parts	A351/A351M
Steel Castings, Ferritic and Martensitic, for Pressure-Containing Parts, Suitable for Low-Temperature Service	A352/A352M
Steel Castings, Alloy, Specially Heat-Treated, for Pressure-Containing Parts, Suitable for High-Temperature Service	A389/A389M
Steel Castings Suitable for Pressure Service	A487/A487M A990
Castings, Iron-Nickel-Chromium and Nickel Alloys, Specially Controlled for Pressure Retaining Parts for Corrosive Service	A995/A995M
Castings, Austenitic-Ferritic (Duplex) Stainless Steel, for Pressure-Containing Parts	

1.2 This specification also covers a group of supplementary requirements which may be applied to the above specifications as indicated therein. These are provided for use when additional testing or inspection is desired and apply only when specified individually by the purchaser in the order.

1.3 In case of conflict between the requirements of the individual specification and this general specification, the former shall prevail.

1.4 The values stated in either SI units or inch-pound units are to be regarded separately as standard. The values stated in each system may not be exact equivalents; therefore, each system shall be used independently of the other. Combining values from the two systems may result in non-conformance with the standard.

2. Referenced Documents

2.1 *ASTM Standards*:³

[A216/A216M Specification for Steel Castings, Carbon, Suitable for Fusion Welding, for High-Temperature Service](#)

[A217/A217M Specification for Steel Castings, Martensitic Stainless and Alloy, for Pressure-Containing Parts, Suitable for High-Temperature Service](#)

[A351/A351M Specification for Castings, Austenitic, for Pressure-Containing Parts](#)

¹ This specification is under the jurisdiction of ASTM Committee A01 on Steel, Stainless Steel and Related Alloys and is the direct responsibility of Subcommittee A01.18 on Castings.

Current edition approved May 1, 2012; Sept. 1, 2012. Published July 2012; October 2012. Originally approved in 1974. Last previous edition approved in 2011 as A703/A703M—11; A703/A703M – 12. DOI: 10.1520/A0703_A0703M-12-10.1520/A0703_A0703M-12A.

² For ASME Boiler and Pressure Vessel Code applications see related Specification SA-703/SA-703M in Section II of that Code.

³ For referenced ASTM standards, visit the ASTM website, www.astm.org, or contact ASTM Customer Service at service@astm.org. For *Annual Book of ASTM Standards* volume information, refer to the standard's Document Summary page on the ASTM website.

*A Summary of Changes section appears at the end of this standard

- A352/A352M** Specification for Steel Castings, Ferritic and Martensitic, for Pressure-Containing Parts, Suitable for Low-Temperature Service
- A370** Test Methods and Definitions for Mechanical Testing of Steel Products
- A380** Practice for Cleaning, Descaling, and Passivation of Stainless Steel Parts, Equipment, and Systems
- A389/A389M** Specification for Steel Castings, Alloy, Specially Heat-Treated, for Pressure-Containing Parts, Suitable for High-Temperature Service
- A487/A487M** Specification for Steel Castings Suitable for Pressure Service
- A488/A488M** Practice for Steel Castings, Welding, Qualifications of Procedures and Personnel
- A609/A609M** Practice for Castings, Carbon, Low-Alloy, and Martensitic Stainless Steel, Ultrasonic Examination Thereof
- A751** Test Methods, Practices, and Terminology for Chemical Analysis of Steel Products
- A800/A800M** Practice for Steel Casting, Austenitic Alloy, Estimating Ferrite Content Thereof
- A802/A802M** Practice for Steel Castings, Surface Acceptance Standards, Visual Examination
- A903/A903M** Specification for Steel Castings, Surface Acceptance Standards, Magnetic Particle and Liquid Penetrant Inspection
- A941** Terminology Relating to Steel, Stainless Steel, Related Alloys, and Ferroalloys
- A967** Specification for Chemical Passivation Treatments for Stainless Steel Parts
- A990** Specification for Castings, Iron-Nickel-Chromium and Nickel Alloys, Specially Controlled for Pressure Retaining Parts for Corrosive Service
- A991/A991M** Test Method for Conducting Temperature Uniformity Surveys of Furnaces Used to Heat Treat Steel Products
- A995/A995M** Specification for Castings, Austenitic-Ferritic (Duplex) Stainless Steel, for Pressure-Containing Parts
- E29** Practice for Using Significant Digits in Test Data to Determine Conformance with Specifications
- E94** Guide for Radiographic Examination
- E125** Reference Photographs for Magnetic Particle Indications on Ferrous Castings
- E165** Practice for Liquid Penetrant Examination for General Industry
- E186** Reference Radiographs for Heavy-Walled (2 to 4½-in. (50.8 to 114-mm)) Steel Castings
- E208** Test Method for Conducting Drop-Weight Test to Determine Nil-Ductility Transition Temperature of Ferritic Steels
- E280** Reference Radiographs for Heavy-Walled (4½ to 12-in. (114 to 305-mm)) Steel Castings
- E340** Test Method for Macroetching Metals and Alloys
- E446** Reference Radiographs for Steel Castings Up to 2 in. (50.8 mm) in Thickness
- E709** Guide for Magnetic Particle Testing
- 2.2 *ANSI Standard:*⁴
- B16.5** Pipe Flanges and Flanged Fittings
- 2.3 *Standards of the Manufacturer's Standardization Society of the Valve and Fitting Industry:*⁵
- MSS SP 53** Quality Standard for Steel Castings and Forgings for Valves, Flanges and Fittings and Other Piping Components (Magnetic Particle Exam Method)
- MSS SP 54** Quality Standard for Steel Castings for Valves, Flanges, and Fittings and Other Piping Components (Radiographic Examination Method)

3. Terminology

3.1 Definitions:

3.1.1 The definitions in Test Methods and Definitions **A370** and Terminology **A941** are applicable to this specification and those listed in **1.1**.

3.1.2 *chaplet, n*—a chaplet is a metallic support placed in a mold cavity to maintain the spacing between a core and the mold.

3.1.3 *electronic data interchange (EDI), n*—the computer-to-computer exchange of business information in a standard format such as ANSI ASC X12.

3.1.4 *heat, n*—all the molten metal poured from a single furnace or all the molten metal from two or more furnaces poured into a single ladle or casting prior to the replenishing of the furnace(s).

3.1.5 *internal chill, n*—an internal chill is a metallic device placed in a mold cavity to increase the rate of heat removal at that location.

3.1.6 *test coupon, n*—the part from which the test specimen will be extracted.

3.1.7 *test specimen, n*—the part that will be acted upon in a mechanical test.

⁴ Available from American National Standards Institute (ANSI), 25 W. 43rd St., 4th Floor, New York, NY 10036, <http://www.ansi.org>.

⁵ Available from Manufacturers Standardization Society of the Valve and Fittings Industry (MSS), 127 Park St., NE, Vienna, VA 22180-4602, <http://www.mss-hq.com>.

4. Materials and Manufacture

4.1 *Melting Process*—The steel shall be made by open-hearth or electric-furnace process, with or without separate refining such as argon-oxygen-decarburization (AOD), unless otherwise designated by the individual specification.

4.2 Heat Treatment:

4.2.1 Ferritic and martensitic steel shall be cooled after pouring to provide substantially complete transformation of austenite prior to heat treatment to enhance mechanical properties.

4.2.2 Castings shall be heat treated in the working zone of a furnace that has been surveyed in accordance with Test Method **A991/A991M**.

4.2.2.1 When castings are heat treated at temperatures above 2000°F [1100°C], then the working zone shall have been established by a survey performed at not more than 25°F [15°C] below nor more than 200°F [110°C] above the minimum heat treatment temperature specified for the grade. If a minimum heat treatment temperature is not specified for the grade, then the survey temperature shall be not more than 50°F [30°C] below nor more than 175°F [100°C] above the furnace set point used.

4.2.2.2 The maximum variation in measured temperature as determined by the difference between the highest temperature and the lowest temperature shall be as agreed between the purchaser and producer except that during production heat treatment, no portion of the furnace shall be below the minimum specified temperature nor above the maximum specified temperature for the grade being processed.

5. Chemical Composition

5.1 *Chemical Analysis*—Chemical analysis of materials covered by this specification shall be in accordance with Test Methods **A751**.

5.2 *Heat Analysis*—An analysis of each heat shall be made by the manufacturer to determine the percentages of the elements specified. The analysis shall be made from a test sample preferably taken during the pouring of the heat. When drillings are used, they shall be taken not less than ¼ in. [6.4 mm] beneath the surface. The chemical composition thus determined shall be reported to the purchaser, or his representative, and shall conform to the requirements in the individual specification for the grade being poured.

5.3 *Product Analysis*—A product analysis may be made by the purchaser from material representing each heat, lot, or casting. The analysis shall be made on representative material. Due to the possibility of decarburization, carbon and alloy steel samples for carbon analysis shall be taken no closer than ¼ in. [6.4 mm] to a cast surface except that castings too thin for this shall be analyzed on representative material. The chemical composition thus determined shall meet the requirements specified in the applicable specification for the grade involved, or shall be subject to rejection by the purchaser, except that the chemical composition determined for carbon and low-alloy steel castings may vary from the specified limits by the amounts shown in **Table 1**. The product analysis tolerances of **Table 1** are not applicable as acceptance criteria for heat analysis by the casting manufacturer.

5.4 *Unspecified Elements*—When chemical analysis for elements not specified for the grade ordered is desired, Supplementary Requirement S1 may be specified.

5.5 *Grade substitution*—Grade substitution is not permitted. Grade substitution occurs when the material being supplied contains one or more elements that are not specified for the supplied material such that the material conforms to the requirements of a different grade.

5.6 Where more than one ladle is poured into a single casting, the molten metal in each ladle must conform to the specified chemical requirements.

6. Mechanical Test Methods

6.1 All mechanical tests shall be conducted in accordance with Test Methods and Definitions **A370**.

7. Tensile Requirements

7.1 One tension test shall be made from each heat, and shall conform to the tensile requirements specified. Test coupons shall be cast from the same heat as the castings represented, except that for investment castings, the test coupons shall be cast in the same type of mold as the castings.⁶

7.2 The coupon from which the test specimen is taken shall be heat treated in production furnaces to the same procedure as the castings it represents.

7.3 Test specimens may be cut from heat-treated castings, at the producer's option, instead of from test coupons.

7.4 *Investment Castings*—For investment castings, the coupons may be cast to shape or machined from coupons to dimensions in accordance with Test Methods and Definitions **A370** or the ICI coupon shown in **Fig. 1**.

⁶ Information on the relationship of mechanical properties determined on test coupons obtained as specified in 7.1 and 7.4 with those obtained from the casting may be found in *The Steel Castings Handbook*, Fifth Edition, Steel Founders' Society of America, 1980, pp. 15-35 through 15-43.

**TABLE 1 Product Analysis Tolerances for Carbon and Low-Alloy Steels**

Element	Range ^A	Tolerances ^{B,C} over max or under min, Limit, %
Carbon (C)	up to 0.65 %	$0.03 \times \% C_L + 0.02$
	above 0.65 %	0.04 %
Manganese (Mn)	up to 1 %	$0.08 \times \% Mn_L + 0.01$
	above 1 %	0.09
Silicon (Si)	up to 0.60 %	$0.22 \times \% Si_L - 0.01$
	above 0.60 %	0.15 %
Phosphorus (P)	all	$0.13 \times \% P_L + 0.005$
Sulfur (S)	all	$0.36 \times \% S_L + 0.001$
Nickel (Ni)	up to 2 %	$0.10 \times \% Ni_L + 0.03$
	above 2 %	0.25 %
Chromium (Cr)	up to 2 %	$0.07 \times \% Cr_L + 0.04$
	above 2 %	0.18 %
Molybdenum (Mo)	up to 0.6 %	$0.04 \times \% Mo_L + 0.03$
	above 0.6 %	0.06 %
Vanadium (V)	up to 0.25 %	$0.23 \times \% V_L + 0.004$
	above 0.25 %	0.06 %
Tungsten (W)	up to 0.10 %	$0.08 \times \% W_L + 0.02$
	above 0.10 %	0.02 %
Copper (Cu)	up to 0.15 %	$0.18 \times \% Cu_L + 0.02$
	above 0.15 %	0.05 %
Aluminum (Al)	up to 0.03 %	0.01 %
	0.03 to 0.10 %, incl.	$0.08 \times \% Al + 0.02$
	above 0.10 %	0.03 %

^A The range denotes the composition limits up to which the tolerances are computed by the equation, and above which the tolerances are given by a constant.

^B The subscript _L for the elements in each equation indicates that the limits of the element specified by the applicable specification are to be inserted into the equation to calculate the tolerance for the upper limit and the lower limit, if applicable, respectively. Examples of computing tolerances are presented in the footnote C.

^C To compute the tolerances, consider the manganese limits 0.50 – 80 % of Grade WC4 of Specification A217/A217M. In accordance with Table 1, the maximum permissible deviation of a product analysis below the lower limit 0.50 is $0.05 \% = (0.08 \times 0.50 + 0.01)$. The lowest acceptable product analysis of Grade WC4, therefore, is 0.45 %. Similarly, the maximum permissible deviation above the upper limit of 0.80 % is $0.074 \% = (0.08 \times 0.80 + 0.01)$. The highest acceptable product analysis of Grade WC4, therefore, is 0.874. For Grade WCC of Specification A216/A216M, the maximum manganese content is 1.40 % if the carbon content is 0.20 %. In this case, the highest acceptable product analysis is $1.49 = (1.40 + 0.09)$.

<https://standards.iteh.ai/catalog/standards/sist/2a51080d-93f4-4ae2-9123-4e7f401bd30f/astm-a703-a703m-12a>

7.5 Other Castings—Unless otherwise specified by the purchaser, test coupons may be cast integrally with the castings or as separately in accordance with Fig. 2 and Table 2, with Fig. 3, or with Fig. 4, except when Supplementary Requirement S26 is specified. The test coupon in Fig. 4 shall be employed only for austenitic alloy castings with cross sections less than 2½ in. [63.5 mm]. Tension test specimens shall be prepared in accordance with Test Methods and Definitions A370.

7.6 If any specimen shows defective machining or develops flaws, it may be discarded and another substituted from the same heat.

7.7 To determine conformance with the tension test requirements, an observed value or calculated value shall be rounded off in accordance with Practice E29 to the nearest 500 psi [5 MPa] for yield and tensile strength and to the nearest 1 % for elongation and reduction of area.

8. Repair by Welding

8.1 Repair by welding shall be in accordance with the requirements of individual specification using procedures and welders qualified in accordance with Practice A488/A488M.

9. Flanges

9.1 When a flange from a flanged casting is removed to make a weld end casting, discontinuities may be observed that would not have been detrimental in a flanged casting. The disposition of the casting shall be subject to agreement between the purchaser and manufacturer.

10. Quality

10.1 The surface of the casting shall be free of adhering sand, scale, cracks, and hot tears as determined by visual examination. Other surface discontinuities shall meet the visual acceptance standards specified in the order. Practice A802/A802M or other

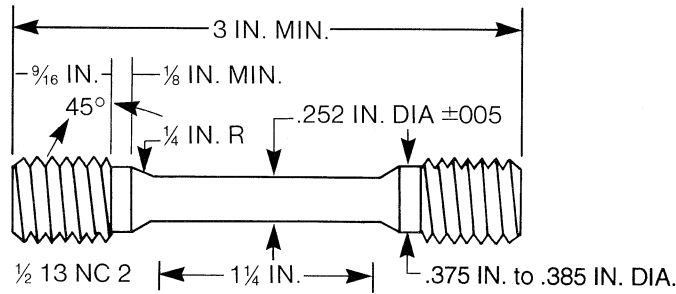

Metric Equivalents

in.	0.005	1/8	0.252	0.375	0.385	9/16	1/4	3
[mm]	[0.15]	[3]	[6.40]	[9.50]	[9.75]	[15]	[30]	[75]

FIG. 1 Design and Dimensions of the ICI Test Coupon

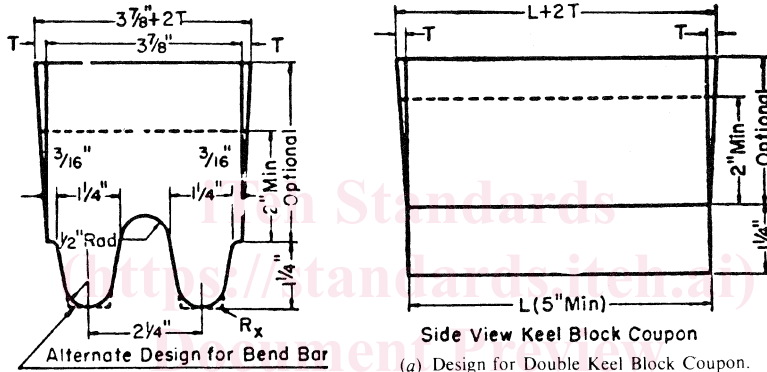

(a) Design for Double Keel Block Coupon.

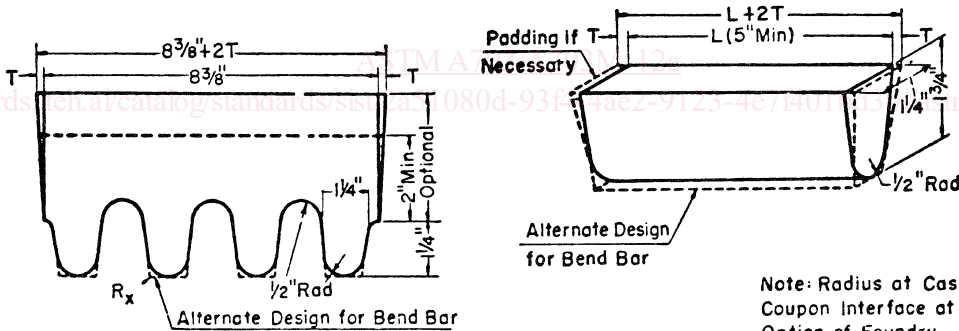

(b) Design for Multiple Keel Block Coupon (4 Legs).

(c) Design for "Attached" Coupon.

Metric Equivalents

in.	3/16	1/2	1 1/4	1 3/4	2	2 1/4	3/8	5	8 1/8
mm	4.8	13	32	45	51	57	98	127	213

FIG. 2 Test Coupons for Castings (see Table 2 for Details of Design)

visual standards may be used to define acceptable surface discontinuities and finish. Unacceptable visual surface discontinuities shall be removed and their removal verified by visual examination of the resultant cavities.

10.2 The castings shall not be peened, plugged, or impregnated to stop leaks or disguise rejectable indications.

10.3 Internal chills and chaplets may be used in the manufacture of castings. However, the chills, chaplets, and affected cast material must be completely removed.

11. Hydrostatic Tests

11.1 Each casting shall be tested after machining to the hydrostatic shell test pressures prescribed in ANSI B16.5 for the applicable steel rating for which the casting is designed. Casting shall show no leaks. Castings ordered for working pressures other

TABLE 2 Details of Test Coupon Design for Casting (See Fig. 2)

NOTE 1—*Test Coupons for Large and Heavy Steel Castings:* The test coupons in Fig. 2 are to be used for large and heavy steel castings. However, at the option of the foundry the cross-sectional area and length of the standard coupon may be increased as desired.

NOTE 2—*Bend Specimen:* If a bend specimen is required, an alternate design (as shown by dotted lines in Fig. 2) is indicated.

Leg Design [125 mm]		Riser Design	
1. <i>L</i> (length)	A5 in. [125 mm] minimum length will be used. This length may be increased at the option of the foundry to accommodate additional test specimens (see Note 1).	1. <i>L</i> (length)	The length of the riser at the base will be the same as the top length of the leg. The length of the riser at the top therefore depends on the amount of taper added to the riser.
2. End taper	Use of and size of end taper is at the option of the foundry.	2. Width	The width of the riser at the base of a multiple-leg coupon shall be $n, 2\frac{1}{4}$ [57 mm] – $\frac{5}{8}$ [16 mm] where <i>n</i> equals the number of legs attached to the coupon. The width of the riser at the top is therefore dependent on the amount of taper added to the riser.
3. Height	1 $\frac{1}{4}$ in. [32 mm]	3. <i>T</i> (riser taper)	Use of and size is at the option of the foundry.
4. Width (at top)	1 $\frac{1}{4}$ in. [32 mm] (see Note 1).	4. Height	The minimum height of the riser shall be 2 in. [51 mm]. The maximum height is at the option of the foundry for the following reasons: (1) Many risers are cast open, (2) different compositions may require variation in risering for soundness, (3) different pouring temperatures may require variation in risering for soundness.
5. Radius (at bottom)	$\frac{1}{2}$ in. [13 mm], max		
6. Spacing between legs	A $\frac{1}{2}$ -in. [13-mm] radius will be used between the legs.		
7. Location of test specimens	The tensile, bend, and impact specimens will be taken from the lower portion of the leg (see Note 2).		
8. Number of legs	The number of legs at the option of the foundry providing they are equispaced in accordance with Item 6.		
9. <i>R_s</i>	Radius from 0 to approximately $\frac{1}{16}$ in. [2 mm].		

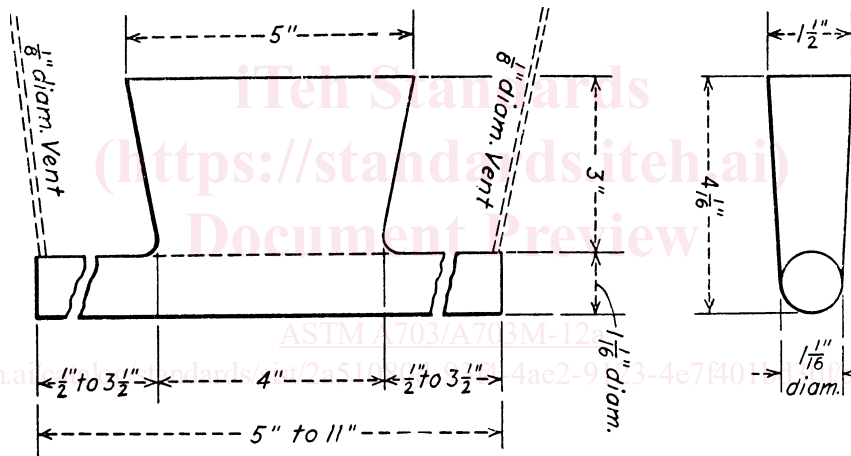

Metric Equivalents

in.	mm	in.	mm
$\frac{1}{8}$	3.2	$3\frac{1}{2}$	88.9
$\frac{1}{2}$	12.7	4	101.6
$1\frac{1}{16}$	27.0	$4\frac{1}{16}$	103.2
$1\frac{1}{2}$	38.1	5	127.0
3	76.2	11	279.4

NOTE 1—Pour through head; cover molten head with powdered charcoal, coke dust, and so forth, immediately after pouring, in order to keep head fluid as long as possible.

FIG. 3 Test Coupon for Tension Test

than those in the standard ANSI ratings, or those listed for which test pressures are not specified by ANSI B16.5, shall be tested at a pressure agreed upon between manufacturer and the purchaser.

11.2 It is realized that the foundry may be unable to perform the hydrostatic test prior to shipment, or that the purchaser may wish to defer testing until additional work or machining has been performed on the casting. Castings ordered in the rough state for final machining by the purchaser may be tested hydrostatically prior to shipment by the manufacturer at pressures to be agreed upon with the purchaser. However, the foundry is responsible for the satisfactory performance of the castings under the final test required in 11.1.