

FINAL
DRAFT

INTERNATIONAL
STANDARD

ISO/FDIS
5287

ISO/TC 41/SC 1

Secretariat: AFNOR

Voting begins on:
2021-04-27

Voting terminates on:
2021-06-22

Belt drives — V-belts for the automotive industry — Fatigue test

Transmission par courroies - Courroies trapézoïdales pour l'industrie automobile - Essai de fatigue

iTeh STANDARD PREVIEW
(standards.iteh.ai)

[ISO/FDIS 5287](https://standards.iteh.ai/catalog/standards/sist/5cd62837-86a4-41ed-8a72-6486155e98f7/iso-fdis-5287)

<https://standards.iteh.ai/catalog/standards/sist/5cd62837-86a4-41ed-8a72-6486155e98f7/iso-fdis-5287>

RECIPIENTS OF THIS DRAFT ARE INVITED TO SUBMIT, WITH THEIR COMMENTS, NOTIFICATION OF ANY RELEVANT PATENT RIGHTS OF WHICH THEY ARE AWARE AND TO PROVIDE SUPPORTING DOCUMENTATION.

IN ADDITION TO THEIR EVALUATION AS BEING ACCEPTABLE FOR INDUSTRIAL, TECHNOLOGICAL, COMMERCIAL AND USER PURPOSES, DRAFT INTERNATIONAL STANDARDS MAY ON OCCASION HAVE TO BE CONSIDERED IN THE LIGHT OF THEIR POTENTIAL TO BECOME STANDARDS TO WHICH REFERENCE MAY BE MADE IN NATIONAL REGULATIONS.



Reference number
ISO/FDIS 5287:2021(E)

© ISO 2021

iTeh STANDARD PREVIEW
(standards.iteh.ai)

[ISO/FDIS 5287](https://standards.iteh.ai/catalog/standards/sist/5cd62837-86a4-41ed-8a72-6486155e98f7/iso-fdis-5287)

<https://standards.iteh.ai/catalog/standards/sist/5cd62837-86a4-41ed-8a72-6486155e98f7/iso-fdis-5287>



COPYRIGHT PROTECTED DOCUMENT

© ISO 2021

All rights reserved. Unless otherwise specified, or required in the context of its implementation, no part of this publication may be reproduced or utilized otherwise in any form or by any means, electronic or mechanical, including photocopying, or posting on the internet or an intranet, without prior written permission. Permission can be requested from either ISO at the address below or ISO's member body in the country of the requester.

ISO copyright office
CP 401 • Ch. de Blandonnet 8
CH-1214 Vernier, Geneva
Phone: +41 22 749 01 11
Email: copyright@iso.org
Website: www.iso.org

Published in Switzerland

Contents

	Page
Foreword	iv
1 Scope	1
2 Normative references	1
3 Terms and definitions	1
4 Symbols	1
5 Principle	2
6 Apparatus	2
6.1 Dynamic test machine	2
6.2 Test pulleys	3
7 Test room condition	6
8 Test method	6
8.1 Test conditions	6
8.2 Procedure	7
8.2.1 Preparation	7
8.2.2 Test	7
8.2.3 Retensioning	8
9 Test report	8

iTeh STANDARD PREVIEW
(standards.iteh.ai)

[ISO/FDIS 5287](https://standards.iteh.ai/catalog/standards/sist/5cd62837-86a4-41ed-8a72-6486155e98f7/iso-fdis-5287)

<https://standards.iteh.ai/catalog/standards/sist/5cd62837-86a4-41ed-8a72-6486155e98f7/iso-fdis-5287>

Foreword

ISO (the International Organization for Standardization) is a worldwide federation of national standards bodies (ISO member bodies). The work of preparing International Standards is normally carried out through ISO technical committees. Each member body interested in a subject for which a technical committee has been established has the right to be represented on that committee. International organizations, governmental and non-governmental, in liaison with ISO, also take part in the work. ISO collaborates closely with the International Electrotechnical Commission (IEC) on all matters of electrotechnical standardization.

The procedures used to develop this document and those intended for its further maintenance are described in the ISO/IEC Directives, Part 1. In particular, the different approval criteria needed for the different types of ISO documents should be noted. This document was drafted in accordance with the editorial rules of the ISO/IEC Directives, Part 2 (see www.iso.org/directives).

Attention is drawn to the possibility that some of the elements of this document may be the subject of patent rights. ISO shall not be held responsible for identifying any or all such patent rights. Details of any patent rights identified during the development of the document will be in the Introduction and/or on the ISO list of patent declarations received (see www.iso.org/patents).

Any trade name used in this document is information given for the convenience of users and does not constitute an endorsement.

For an explanation of the voluntary nature of standards, the meaning of ISO specific terms and expressions related to conformity assessment, as well as information about ISO's adherence to the World Trade Organization (WTO) principles in the Technical Barriers to Trade (TBT), see www.iso.org/iso/foreword.html.

This document was prepared by Technical Committee ISO/TC 41, *Pulleys and belts (including veebelts)*, Subcommittee SC 1, *Friction*.

This fourth edition cancels and replaces the third edition (ISO 5287:2003), which has been technically revised. The main changes compared to the previous edition are as follows:

- symbols table has been added;
- cogged type has been added;
- fatigue test conditions of AV 17 type have been added;
- datum width of fatigue test pulley has been deleted.

Any feedback or questions on this document should be directed to the user's national standards body. A complete listing of these bodies can be found at www.iso.org/members.html.

Belt drives — V-belts for the automotive industry — Fatigue test

1 Scope

This document specifies a fatigue test for the quality control of V-belts (sections AV 10, AV 10X, AV 13, AV 13X, AV 17 and AV 17X) intended for driving the auxiliaries of internal combustion engines used for automotive purposes.

NOTE The dimensional characteristics of these belts and of the corresponding pulleys are the subject of ISO 2790.

2 Normative references

The following documents are referred to in the text in such a way that some or all of their content constitutes requirements of this document. For dated references, only the edition cited applies. For undated references, the latest edition of the referenced document (including any amendments) applies.

ISO 683-1, *Heat-treatable steels, alloy steels and free-cutting steels — Part 1: Non-alloy steels for quenching and tempering*

ISO 2790, *Belt drives — V-belts for the automotive industry and corresponding pulleys — Dimensions*

ISO 4287, *Geometrical Product Specifications (GPS) — Surface texture: Profile method — Terms, definitions and surface texture parameters*

ISO 6508-1, *Metallic materials — Rockwell hardness test — Part 1: Test method*

3 Terms and definitions

No terms and definitions are listed in this document.

ISO and IEC maintain terminological databases for use in standardization at the following addresses:

- ISO Online browsing platform: available at <https://www.iso.org/obp>
- IEC Electropedia: available at <https://www.electropedia.org/>

4 Symbols

For the purpose of this document, the following symbols apply.

Symbol	Definition	Unit
C	centre distance between the driving and driven pulleys	mm
d_{e1}	effective diameter of both the driving and driven pulleys	mm
d_{e2}	effective diameter of the idler pulley	mm
F	belt tensioning force	N
g	additional slip	%
i_o	rotational frequency ratio at the initial	—
i_f	rotational frequency ratio at measurement of the additional slip	—
L_e	effective length of the belt	mm

Symbol	Definition	Unit
K	factor for the belt tensioning force	N/kW
n_0	initial rotational frequency of the driven shaft	min ⁻¹
n_f	final rotational frequency of the driven shaft	min ⁻¹
N_0	initial rotational frequency of the driving shaft	min ⁻¹
N_f	final rotational frequency of the driving shaft	min ⁻¹
p	minimum groove depth	mm
P	transmitted power	kW
r	minimum curve radius of the sides as the top of the groove	mm
R_a	surface roughness	μm
w_e	effective width	mm
α	groove angle of the driving pulley and of the driven pulley	degree

5 Principle

Determination of the performance of a belt under specified conditions on the two- or three-pulley test machine described in [6.1](#).

The shortest V-belt that can be tested on the three-pulley test machine is approximately 800 mm. Shorter belts should be tested on the two-pulley test machine, as described in [Clauses 6](#) and [8](#).

A number of conditions shall be agreed between the manufacturer and the user, including the power to be transmitted, the effective diameter of the idler pulley and the number of times the belt can be re-tensioned, and the minimum acceptable belt life, in hours.

As a general rule, the power to be transmitted using the two-pulley test machine shall be approximately 70 % of the power transmitted using the three-pulley test machine.

Belt failure occurs when the belt no longer satisfies the agreed conditions.

6 Apparatus

6.1 Dynamic test machine

Dynamic test machine, of robust design so that all components withstand, with virtually no deflection, the stresses to which they are subjected.

6.1.1 Driving pulley and suitable mechanism for driving it.

6.1.2 Driven pulley, to which a suitable power-absorption unit is connected.

6.1.3 Power-absorption unit, accurate and capable of calibration, e.g. by dead weights.

6.1.4 Device, through which tension can be applied to the belt:

- a) in the case of the three-pulley test machine layout, an idler pulley (see [Figure 1](#));
- b) in the case of the two-pulley test machine layout, a movable pulley (see [Figure 2](#)).

6.1.5 Means of determining belt slip, to an accuracy of ± 1 %.

The layout of the pulleys and the direction of rotation shall be as shown in [Figures 1](#) and [2](#).

In order to accommodate different lengths of belt, the position of the driving and driven elements, and the position of the idler pulley and its support bracket in the case of the three-pulley test machine, shall be adjustable so that the test layout of the pulleys is attainable for each belt length.

So that tension can be satisfactorily applied to the belt, and in order to allow for belt stretch, the idler pulley of the three-pulley test machine and its bearing assembly shall be free to slide, as and when necessary, in its support bracket along the line of application of the tensioning force. In such a case, the line of action of the tensioning force shall bisect the belt layout angle at the idler pulley, shall pass through the axis centre of the idler pulley, and shall lie in the plane through the centre of the groove of the idler pulley (see [Figure 1](#)).

The two-pulley test machine shall be constructed so that one of the units (driven or driving) can be moved to accommodate belt lengths up to 800 mm (see [Figure 2](#)). A method of locking the movable unit in position, with a given tension in the V-belt, shall be provided.

6.2 Test pulleys

Test pulleys, which shall comply with the following requirements: be made of steel as defined in ISO 683-1, with a surface hardness of 55 HRC, in accordance with ISO 6508-1, and the pulley groove with a surface roughness such that the arithmetical mean deviation of the evaluated profile, R_a , defined by ISO 4287 is lower than 0,8 μm .

The characteristics of the test pulleys are given in [Figure 3](#) and [Table 1](#).

iTeh STANDARD PREVIEW (standards.iteh.ai)

[ISO/FDIS 5287](#)

<https://standards.iteh.ai/catalog/standards/sist/5cd62837-86a4-41ed-8a72-6486155e98f7/iso-fdis-5287>

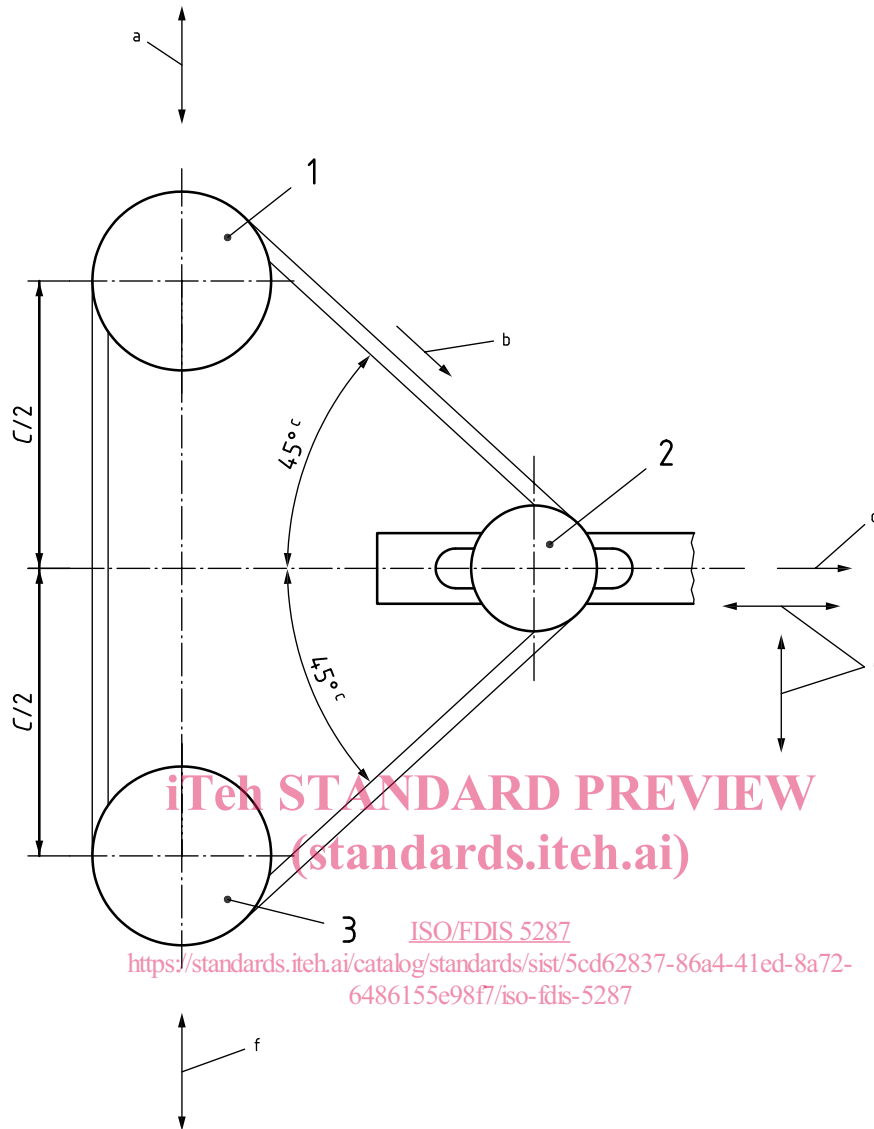

Key

1 driven pulley (power-absorption unit)
 2 idler pulley — set in slide
 3 driving pulley

The belt, mounted on the test pulleys, should be aligned to within $\pm 0,25^\circ$ in relation to the plane through the centre of each pulley groove.

a Direction of adjustment of driven pulley.
 b Direction of rotation.
 c 45° is specified for the initial test layout, and may change slightly with retensioning during the course of the test.
 d Belt tensioning force applied to the idler pulley.
 e Directions of adjustment of idler pulley assembly and its support bracket.
 f Direction of adjustment of driving pulley.

<https://standards.iteh.ai/catalog/standards/sist/5cd62837-86a4-41ed-8a72-6486155e98f7/iso-fdis-5287>

Figure 1 — Three-pulley test machine layout

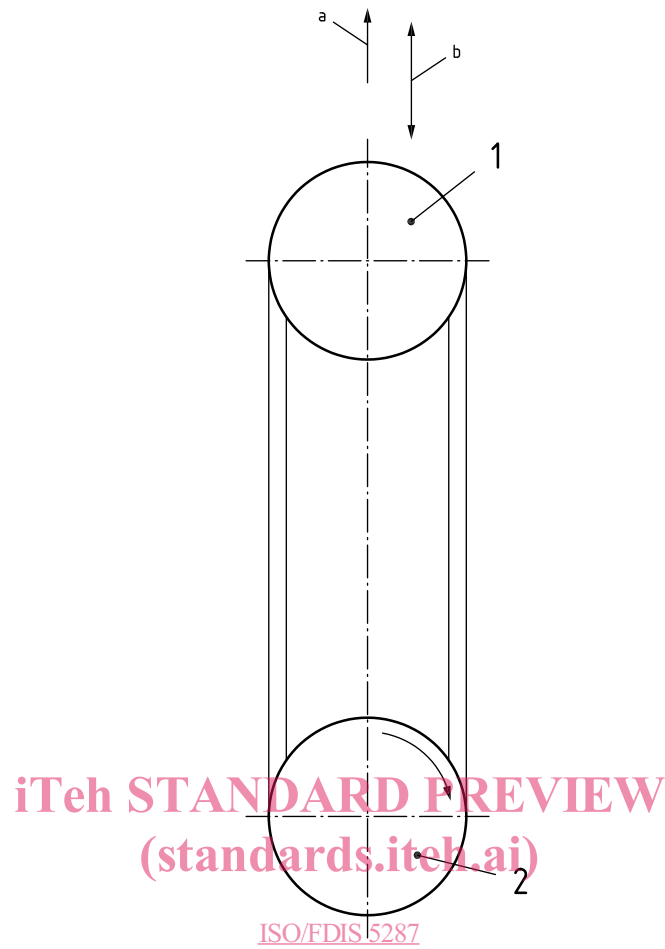

ISO/FDIS 5287

<https://standards.iteh.ai/catalog/standards/sist/5cd62837-86a4-41ed-8a72-6486155e98f7/iso-fdis-5287>

Key

- 1 driven pulley (power-absorption unit)
- 2 driving pulley

The belt, mounted on the test pulleys, should be aligned to within $\pm 0,25^\circ$ in relation to the plane through the centre of each pulley groove.

- a Belt tensioning force applied to the movable pulley.
- b Direction of adjustment of the movable pulley (method of locking in place).

Figure 2 — Two-pulley test machine layout

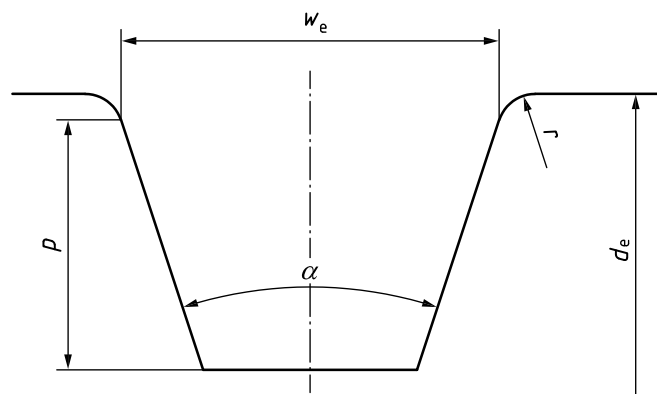

Figure 3 — Test pulley groove

Table 1 — Characteristics of test pulley groove

Dimensions in millimetres

Designation	Symbol	Section		
		AV 10	AV 13	AV 17
Effective diameter of the driving pulley and of the driven pulley (three-pulley test machine)	d_{e1}	$121 \pm 0,2$	$127 \pm 0,2$	$127 \pm 0,2$
Effective diameter of the driving pulley and of the driven pulley (two-pulley test machine)	d_{e1}	$63 \pm 0,2$	$76 \pm 0,2$	$85 \pm 0,2$
Effective diameter of the idler pulley ^a (three-pulley test machine)	d_{e2}	$57 - 63 - 76 \pm 0,2$	$70 - 76 - 89 \pm 0,2$	$90 - 100 \pm 0,2$
Effective width	w_e	9,7	12,7	16,8
Groove angle of the driving pulley and of the driven pulley	α	$36^\circ \pm 0,5^\circ$	$36^\circ \pm 0,5^\circ$	$36^\circ \pm 0,5^\circ$
Groove angle of the idler pulley (three-pulley test machine)		$36^\circ \pm 0,5^\circ$	$36^\circ \pm 0,5^\circ$	$34^\circ \pm 0,5^\circ$
Minimum groove depth	p	11	13,75	16
Minimum curve radius of the sides as the top of the groove	r	0,8	0,8	1,5

^a When the idler pulley effective diameter is reduced, it should be understood that the life of the belt is reduced too.

7 Test room condition iTech STANDARD PREVIEW

The ambient temperature in the test room shall be between 18 °C and 32 °C, and the mean ambient temperature for the duration of the test shall be given with the result of the test.

The atmosphere in the vicinity of the test drive shall be free of draughts from sources other than the belt drive itself.

8 Test method

8.1 Test conditions

For each test, the general layout of the pulleys relative to each other shall be as shown in [Figures 1](#) and [2](#). The centre distance between the driving and driven pulleys for the three-pulley test machine shall be within ± 2 mm of the value determined from [Formula \(1\)](#).

$$2,414 \times C = L_e - 0,785 \times (3 \times d_{e1} + d_{e2}) - (d_{e1} - d_{e2}) \tag{1}$$

where

C is the centre distance between the driving and driven pulleys;

L_e is the effective length of the belt, which shall be measured in accordance with ISO 2790;

d_{e1} is the effective diameter of both the driving and driven pulleys;

d_{e2} is the effective diameter of the idler pulley.

The rotational frequency of the driving pulley, to within ± 2 %, shall be:

- for AV 10 and AV 10X belts: 4 900 min⁻¹;
- for AV 13, AV 13X, AV 17 and AV 17X belts: 4 700 min⁻¹.