



Standard Specification for Steel Deck Gear Stowage Box [Metric]¹

This standard is issued under the fixed designation F1019M; the number immediately following the designation indicates the year of original adoption or, in the case of revision, the year of last revision. A number in parentheses indicates the year of last reapproval. A superscript epsilon (ϵ) indicates an editorial change since the last revision or reapproval.

1. Scope

1.1 This specification covers the design, material, and manufacture of steel deck gear stowage boxes.

1.2 This specification shall not be used for life preserver or pyrotechnic stowage.

1.3 The values stated in SI units are to be regarded as the standard. The values given in parentheses are for information only.

2. Referenced Documents

2.1 *ASTM Standards*:²

A36/A36M Specification for Carbon Structural Steel
A123/A123M Specification for Zinc (Hot-Dip Galvanized)
Coatings on Iron and Steel Products

2.2 *Other Documents*:

ABS Rules for Building and Classing Steel Vessels³
SSPC Specification 6⁴
AWS D1.1 Structural Welding Code⁵

3. Classification

3.1 *Deck Gear Stowage Boxes*, shall be the following types:

3.1.1 *Type I*—Conforming to all dimensions in Fig. 1, Fig. 2, Fig. 3, Fig. 4, Fig. 5, Fig. 6, Fig. 7, Fig. 8, and Fig. 9.

3.1.2 *Type II*—Conforming only to Fig. 1 configuration and meeting the requirements of Sections 4 – 7, dimensions and material specification made to fit unique requirements of customer.

¹ This specification is under the jurisdiction of ASTM Committee F25 on Ships and Marine Technology and is the direct responsibility of Subcommittee F25.03 on Outfitting and Deck Machinery.

Current edition approved Oct. 1, 2012. Published October 2012. Originally approved in 1986. Last previous edition approved in 2006 as F1019M – 00 (2006). DOI: 10.1520/F1019M-00R12.

² For referenced ASTM standards, visit the ASTM website, www.astm.org, or contact ASTM Customer Service at service@astm.org. For *Annual Book of ASTM Standards* volume information, refer to the standard's Document Summary page on the ASTM website.

³ Available from American Bureau of Shipping, ABS Plaza, 16855 Northchase Dr., Houston, TX 77060.

⁴ Available from Society for Protective Coatings (SSPC), 40 24th St., 6th Floor, Pittsburgh, PA 15222-4656.

⁵ Available from American Welding Society, 550 N.W. Le Jeune Rd., Miami, FL 33126.

4. Ordering Information

4.1 Order using this ASTM designation, year of issue, and type.

5. Materials and Manufacture

5.1 *Materials*:

5.1.1 The steel for the deck box shall be in accordance with Specification A36/A36M.

5.1.2 Nuts, bolts, and washers shall be corrosion-resistant materials.

5.1.3 Materials used in construction of this box and its packaging shall be free of asbestos and cadmium.

5.2 *Manufacture*:

5.2.1 Stowage boxes shall be constructed in accordance with figures appearing in this standard.

5.2.2 Welding shall be in accordance with ABS Rules for Building and Classing Steel Vessels or AWS D1.1 Structural Welding Code unless otherwise specified.

6. Dimensions and Tolerances

6.1 Dimensions are as indicated.

6.2 *Tolerance*—1.5 mm ($\pm 1/16$ in.).

7. Workmanship, Finish, and Appearance

7.1 The entire assembly shall be free of weld spatter, slag, splinters, sharp edges, projections, and other defects that may be hazardous to personnel.

7.2 The box shall be cleaned after assembly to a commercial finish in accordance with SSPC-SP6.

7.3 All surfaces except gratings and covers shall be coated with one coat of commercial quality anticorrosive, lead-free, chromate-free primer to a minimum dry film thickness of 50 μ m.

7.4 Gratings and covers shall be galvanized in accordance with Specification A123/A123M.

8. Keywords

8.1 box; deck gear stowage boxes; locker; marine; marine stowage boxes; ship; stowage boxes

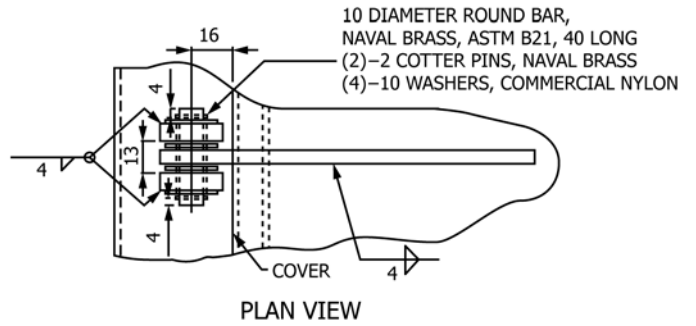
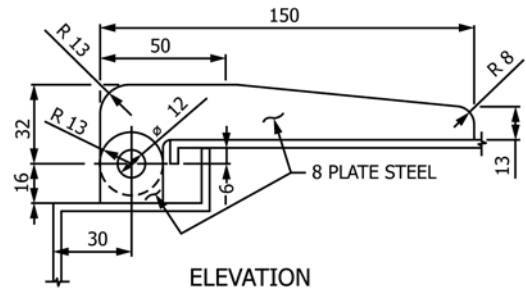
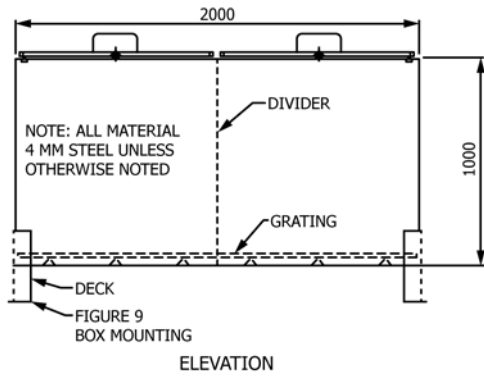

FIG. 2 Hinge

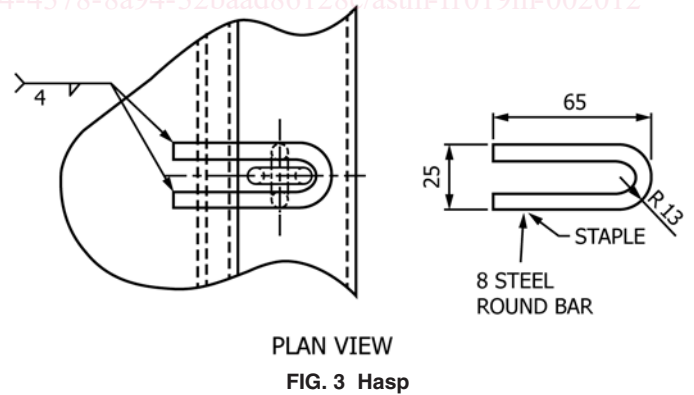
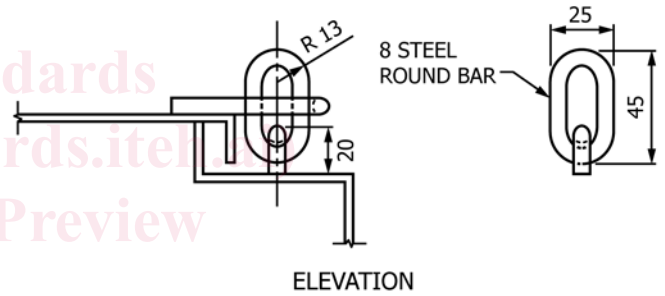

FIG. 3 Hasp

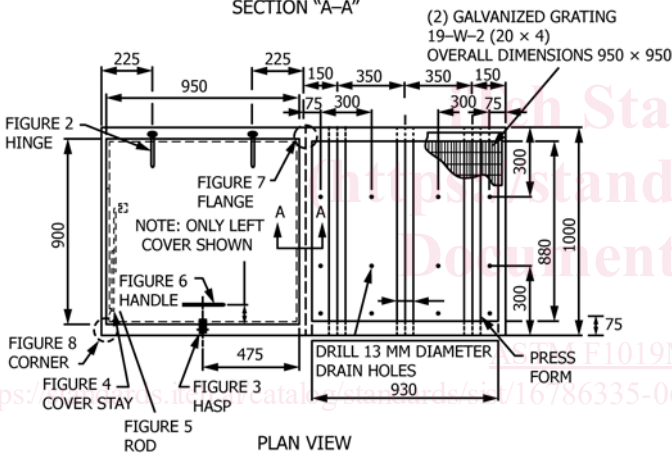
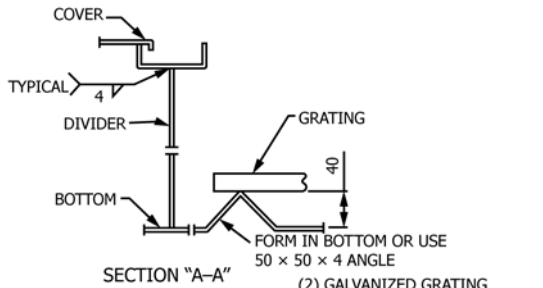

FIG. 1 Steel Deck Gear Stowage Box

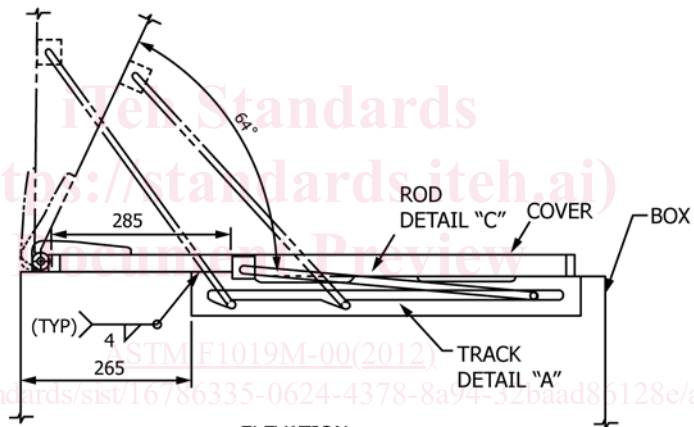
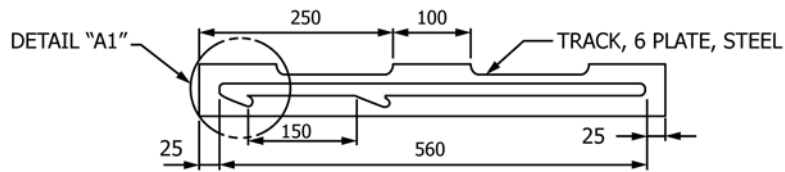
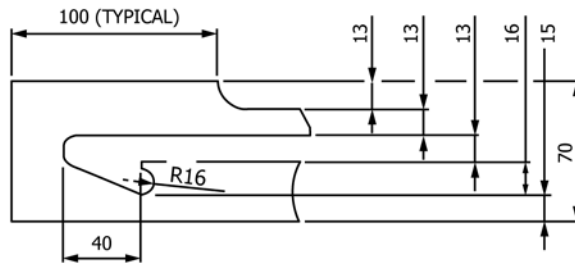

FIG. 4 Cover Stay

<https://standards.iteh.ai/catalog/standards/sist/16756335-0624-4378-8a74-52baad86128e/astm-f1019m-002012>