**Fine ceramics (advanced ceramics,
advanced technical ceramics) — Test
method for determining tensile and
shear creep of ceramic adhesive**

iTeh STANDARD PREVIEW
(standards.iteh.ai)

ISO 5722:2023

<https://standards.iteh.ai/catalog/standards/sist/92638cde-99ee-4975-9c75-0bde5868df1b/iso-5722-2023>



iTeh STANDARD PREVIEW
(standards.iteh.ai)

ISO 5722:2023

<https://standards.iteh.ai/catalog/standards/sist/92638cde-99ee-4975-9c75-0bde5868df1b/iso-5722-2023>



COPYRIGHT PROTECTED DOCUMENT

© ISO 2023

All rights reserved. Unless otherwise specified, or required in the context of its implementation, no part of this publication may be reproduced or utilized otherwise in any form or by any means, electronic or mechanical, including photocopying, or posting on the internet or an intranet, without prior written permission. Permission can be requested from either ISO at the address below or ISO's member body in the country of the requester.

ISO copyright office
CP 401 • Ch. de Blandonnet 8
CH-1214 Vernier, Geneva
Phone: +41 22 749 01 11
Email: copyright@iso.org
Website: www.iso.org

Published in Switzerland

Contents

	Page
Foreword.....	iv
1 Scope	1
2 Normative references	1
3 Terms and definitions	1
4 Principle	2
5 Apparatus	2
6 Test specimen	3
6.1 Test specimen size and preparation.....	3
6.2 Test specimen storage.....	6
7 Test procedures	6
7.1 Measurement of specimen dimensions.....	6
7.2 Measurements of the tensile or shear creep.....	6
7.3 Measurements of the cross-bonded area and thickness.....	9
7.4 Loading procedure.....	9
7.5 Recording of displacement and rupture time.....	9
8 Calculation of results	9
8.1 Calculation of the tensile creep.....	9
8.2 Calculation of the shear creep.....	9
9 Test report	10
Bibliography	11

[ISO 5722:2023](https://standards.iteh.ai/catalog/standards/sist/92638cde-99ee-4975-9c75-0bde5868dflb/iso-5722-2023)

<https://standards.iteh.ai/catalog/standards/sist/92638cde-99ee-4975-9c75-0bde5868dflb/iso-5722-2023>

Foreword

ISO (the International Organization for Standardization) is a worldwide federation of national standards bodies (ISO member bodies). The work of preparing International Standards is normally carried out through ISO technical committees. Each member body interested in a subject for which a technical committee has been established has the right to be represented on that committee. International organizations, governmental and non-governmental, in liaison with ISO, also take part in the work. ISO collaborates closely with the International Electrotechnical Commission (IEC) on all matters of electrotechnical standardization.

The procedures used to develop this document and those intended for its further maintenance are described in the ISO/IEC Directives, Part 1. In particular, the different approval criteria needed for the different types of ISO documents should be noted. This document was drafted in accordance with the editorial rules of the ISO/IEC Directives, Part 2 (see www.iso.org/directives).

Attention is drawn to the possibility that some of the elements of this document may be the subject of patent rights. ISO shall not be held responsible for identifying any or all such patent rights. Details of any patent rights identified during the development of the document will be in the Introduction and/or on the ISO list of patent declarations received (see www.iso.org/patents).

Any trade name used in this document is information given for the convenience of users and does not constitute an endorsement.

For an explanation of the voluntary nature of standards, the meaning of ISO specific terms and expressions related to conformity assessment, as well as information about ISO's adherence to the World Trade Organization (WTO) principles in the Technical Barriers to Trade (TBT), see www.iso.org/iso/foreword.html.

This document was prepared by Technical Committee ISO/TC 206, *Fine ceramics*.

Any feedback or questions on this document should be directed to the user's national standards body. A complete listing of these bodies can be found at www.iso.org/members.html.

Fine ceramics (advanced ceramics, advanced technical ceramics) — Test method for determining tensile and shear creep of ceramic adhesive

1 Scope

This document specifies a testing method for determining the tensile and shear creep of ceramic adhesive at ambient temperature by tensile and shear tests on cross-bonded test specimens. Procedures for test piece preparation, test modes, data collection, creep calculations and reporting are addressed.

This document is applicable primarily to ceramic materials which are used for ceramic-ceramic, ceramic-metal and ceramic-glass joining, including monolithic fine ceramics and whisker- or particulate-reinforced ceramic composites. This test method can be used for material research, quality control, characterization and design data generation purposes.

2 Normative references

The following documents are referred to in the text in such a way that some or all of their content constitutes requirements of this document. For dated references, only the edition cited applies. For undated references, the latest edition of the referenced document (including any amendments) applies.

ISO 3611, *Geometrical product specifications (GPS) — Dimensional measuring equipment: Micrometers for external measurements — Design and metrological characteristics*

ISO 7500-2, *Metallic materials — Verification of static uniaxial testing machines — Part 2: Tension creep testing machines — Verification of the applied force*

ISO 13124, *Fine ceramics (advanced ceramics, advanced technical ceramics) — Test method for interfacial bond strength of ceramic materials*

3 Terms and definitions

For the purposes of this document, the following terms and definitions apply.

ISO and IEC maintain terminology databases for use in standardization at the following addresses:

- ISO Online browsing platform: available at <https://www.iso.org/obp>
- IEC Electropedia: available at <https://www.electropedia.org/>

3.1

tensile creep

time-dependent deformation of a test specimen subjected to a uniaxial tensile load

[SOURCE: ISO 22215:2006, 3.10, modified — “load” replaced “force”.]

3.2

shear creep

time-dependent deformation of a test specimen subjected to a uniaxial shear load

3.3

cross-bonded sample

test piece prepared by joining a pair of rectangular bars to form a symmetrical cross by means of *ceramic adhesive* (3.5)

**3.4
creep rupture time**

time required for a test specimen to fracture under constant force as a result of *tensile creep* (3.1) or *shear creep* (3.2)

[SOURCE: ISO 22215:2006, 3.3, modified — “or shear creep” added.]

**3.5
ceramic adhesive**

adhesive for ceramics bonding, as an interface material between ceramics and other solid materials

4 Principle

For determining the tensile and shear creep strain and creep rupture time of ceramic adhesive, a constant uniaxial load is applied to a cross-bonded sample so that the interface layer (adhesive) is subjected to uniform tension or shearing and the deformation time is recorded.

5 Apparatus

The usual laboratory apparatus and, in particular, the following shall be used.

5.1 Testing machine. The creep testing machine for cross-bonded samples shall be able to apply uniform and constant tensile and shear loads to the connecting layer between the crossed bars. It shall be able to measure the relative displacement between the crossed bars with time. The machine shall be verified and shall be in accordance with ISO 7500-2.

5.2 Data recording system. A calibrated recorder shall be used to record a displacement-time curve. The time interval of the data recording shall be set as required.

5.3 Testing fixture that can mount the cross-bonded samples and load for interface tension and interface shear tests. A threaded structure shall be set on one side of the fixture, the supporting nut shall be inserted into the threaded structure and the grating micrometer shall be fixed by rotating the nut.

The fixture should be made of a hard metal with elastic modulus over 200 GPa and hardness (H_V) over 3 GPa.

5.4 Dimension-measuring device. Micrometers and other devices used for measuring linear dimensions should be accurate to at least 0,01 mm and shall be in accordance with ISO 3611. Alternative dimension-measuring instruments may be used provided that they have a resolution of 0,01 mm or finer.

5.5 Deformation-measuring device. During the creep test, the distance between the fixed bar of the cross-bonded sample and the bar moved due to creep shall be measured by a micrometer with a resolution of 0,001 mm or finer. The time interval for automatically recording deformation shall be set and the displacement-time curve shall be obtained.

The following two recording methods can be selected:

- a) For micrometers with an automatic recording device, the displacement data can be automatically recorded by computer.
- b) For micrometers without an automatic recording device, it is necessary to manually record data with sufficient frequency.

6 Test specimen

6.1 Test specimen size and preparation

The size and preparation of the test specimen shall be in accordance with ISO 13124.

A rectangular test bar with a square or rectangular section shall be prepared before bonding, as shown in [Figure 1](#). The angles of the cross-section should be right-angles within $\pm 1^\circ$. [Table 1](#) shows the recommended dimensions of the bars with the section size of 10 mm \times 10 mm. The length should be larger than 30 mm. The parallelism tolerance on the opposite longitudinal face is 0,015 mm. None of the bar samples shall be chamfered. It is preferable that two rectangle bars with the same dimensions are joined when preparing the cross-sectional samples. The phase compositions of the two rectangle samples can be the same or different.

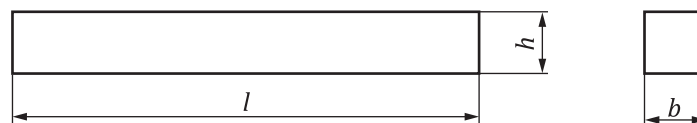

Figure 1 — Schematic illustrations of the rectangle testing specimens

Table 1 — Recommended dimensions for cross-bonded sample and fixture

Dimensions in millimetres

Dimension	Description	Value	Tolerance
l	Bar length	> 30	$\pm 0,5$
b	Width of the bar	10	$\pm 0,1$
h	Thickness of the bar	10	$\pm 0,1$

This document allows several options for test specimen preparation. For creep evaluation of ceramic adhesive, such as glues, the surface of the test specimen does not need polishing. Each pair of bars that need to bond (sometimes of the same material) is joined to form a symmetrical cross. The loading, supporting and jointed areas for the cross-jointed test sample in the test of the tensile or shear creep are shown in [Figure 2](#). The thickness of the adhesive layer for the creep tests shall be over 1 mm. To simulate the interfacial shear creep in practical engineering, the material and thickness of the interfacial layer shall be consistent with the real thing.

Check the cross-bonded sample before the test; the two bars should be perpendicular to each other, and without any redundant overlap at the brim of the bonded area.

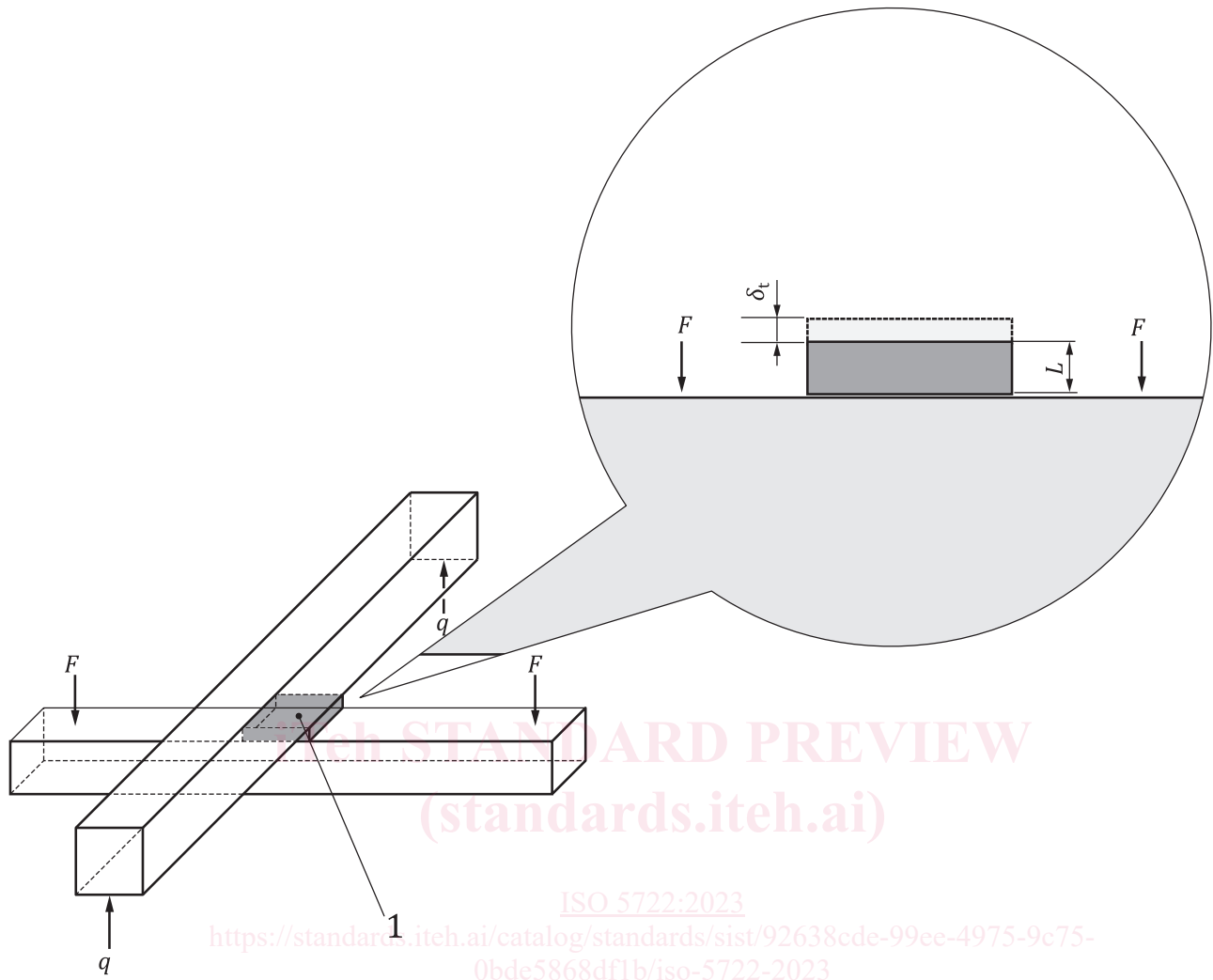

a) Tensile creep

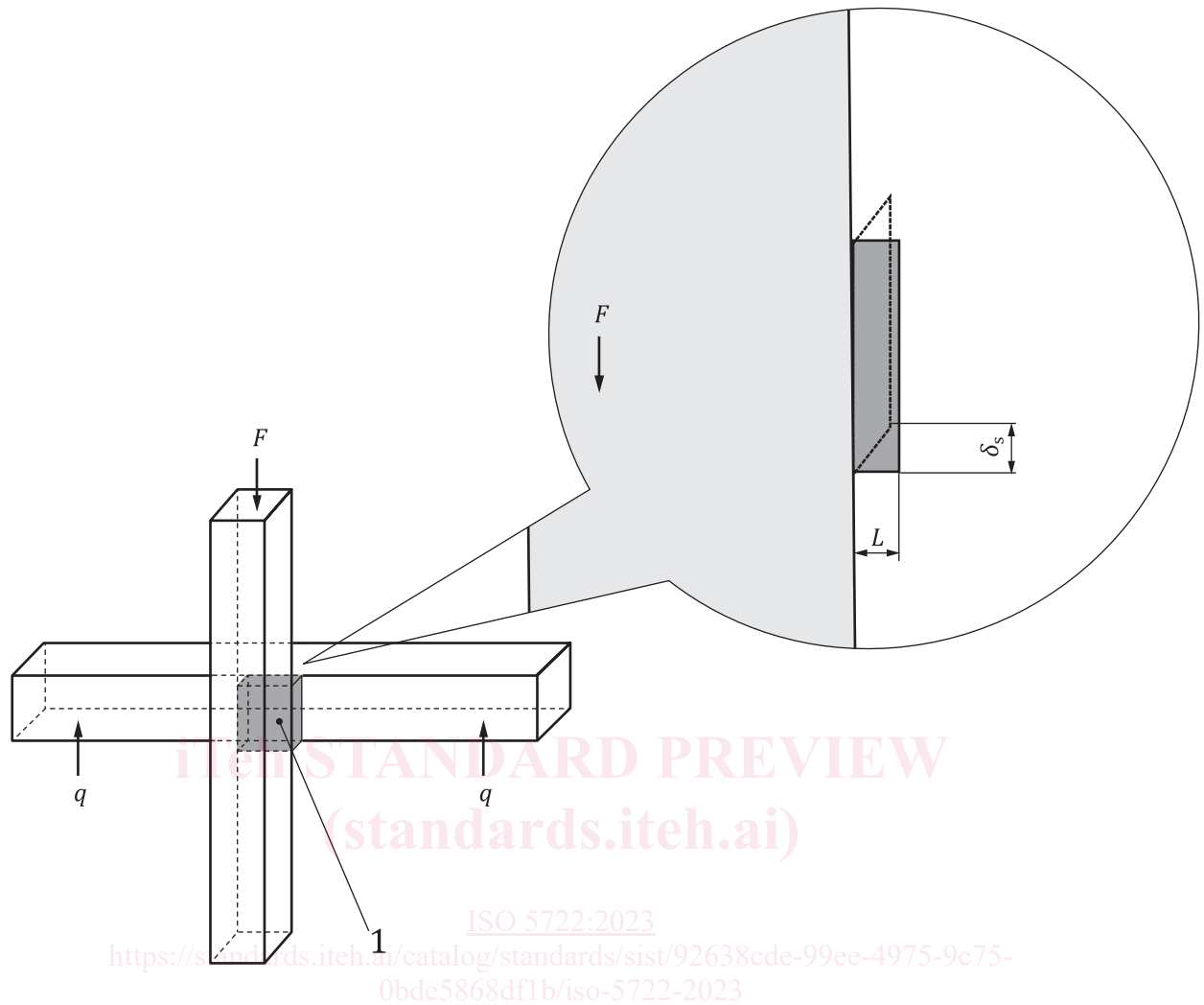

b) Shear creep

Key

- F loading force
- q supported loading
- L initial thickness of ceramic adhesive
- δ_t displacement of the movable bar relative to the fixed bar at the loading direction under tensile creep
- δ_s displacement of the movable bar relative to the fixed bar at the loading direction under shear creep
- 1 ceramic adhesive jointed area (dark)

Figure 2 — Schematic of loading, supporting and jointed area for the cross-jointed test sample

6.2 Test specimen storage

The test specimens shall be handled carefully to avoid the introduction of damage after test specimen preparation. Test specimens shall be stored separately and not allowed to impact or scratch each other.

7 Test procedures

7.1 Measurement of specimen dimensions

The cross-sectional area and thickness of the ceramic adhesive layer for the cross-bonded sample should be determined to within 0,01 mm beforehand by a micrometer as specified in ISO 3611.

7.2 Measurements of the tensile or shear creep

Place each test piece in the tensile creep test fixture, as shown in [Figure 3](#), or the shear creep test fixture, as shown in [Figure 4](#). Apply a constant test force at the specified speed and record the total adhesive deformation by measuring the increasing displacement with time between two bars using a deformation-measuring device. The testing load is stopped at the designed test time or when the cross-bonded sample is in rupture.

Record the deformation at periodic intervals during the test, the total relative displacement, the magnitude and duration of the tensile and shear stress for each test piece.

iTeh STANDARD PREVIEW
(standards.iteh.ai)

[ISO 5722:2023](#)

<https://standards.iteh.ai/catalog/standards/sist/92638cde-99ee-4975-9c75-0bde5868df1b/iso-5722-2023>