**Determination of long-term flow of
geosynthetic drains**

iTeh STANDARD PREVIEW
(standards.iteh.ai)

ISO/PRF TS 18198

<https://standards.iteh.ai/catalog/standards/sist/486d1329-b363-4226-9c4a-ea244ab57e09/iso-prf-ts-18198>

PROOF / ÉPREUVE



iTeh STANDARD PREVIEW
(standards.iteh.ai)

ISO/PRF TS 18198

<https://standards.iteh.ai/catalog/standards/sist/486d1329-b363-4226-9c4a-ea244ab57e09/iso-prf-ts-18198>



COPYRIGHT PROTECTED DOCUMENT

© ISO 2022

All rights reserved. Unless otherwise specified, or required in the context of its implementation, no part of this publication may be reproduced or utilized otherwise in any form or by any means, electronic or mechanical, including photocopying, or posting on the internet or an intranet, without prior written permission. Permission can be requested from either ISO at the address below or ISO's member body in the country of the requester.

ISO copyright office
CP 401 • Ch. de Blandonnet 8
CH-1214 Vernier, Geneva
Phone: +41 22 749 01 11
Email: copyright@iso.org
Website: www.iso.org

Published in Switzerland

Contents

	Page
Foreword.....	iv
Introduction.....	v
1 Scope.....	1
2 Normative references.....	1
3 Terms and definitions.....	1
4 Test equipment and procedures for determination of short-term in- plane water flow.....	1
4.1 Measurement of maximum hydraulic transmissivity and flow rate.....	1
4.2 Test equipment.....	2
4.2.1 Unidirectional flow.....	2
4.2.2 Index and performance tests.....	5
4.3 Normal compressive loading and seating time.....	5
4.4 Number of test specimens per sample per test.....	6
4.5 Hydraulic gradient.....	7
5 Determination of long-term flow performance.....	7
5.1 General.....	7
5.2 Reduction factors (R_F).....	8
5.3 Reduction factor for intrusion ($R_{F,in}$ and $R_{F,GI}$).....	9
5.4 Reduction factor for creep ($R_{F,cr}$).....	10
5.4.1 General.....	10
5.4.2 Time-temperature superposition methods.....	11
5.5 Reduction factors for chemical clogging ($R_{F,CC}$) and biological clogging ($R_{F,BC}$).....	12
5.6 Additional considerations.....	13
5.6.1 Design life.....	13
5.6.2 Design temperature.....	13
5.6.3 Installation damage.....	14
5.6.4 Durability of the polymers.....	14
6 Alternative procedures to determine Q_a.....	14
6.1 General.....	14
6.2 Long-term reduction of water flow capacity due to compressive creep by the BAM (Germany) method.....	14
6.3 Thickness-dependent short-term flow testing using SIM.....	17
6.4 Time dependent loading followed by flow capacity measurements.....	19
Bibliography.....	20

Foreword

ISO (the International Organization for Standardization) is a worldwide federation of national standards bodies (ISO member bodies). The work of preparing International Standards is normally carried out through ISO technical committees. Each member body interested in a subject for which a technical committee has been established has the right to be represented on that committee. International organizations, governmental and non-governmental, in liaison with ISO, also take part in the work. ISO collaborates closely with the International Electrotechnical Commission (IEC) on all matters of electrotechnical standardization.

The procedures used to develop this document and those intended for its further maintenance are described in the ISO/IEC Directives, Part 1. In particular, the different approval criteria needed for the different types of ISO documents should be noted. This document was drafted in accordance with the editorial rules of the ISO/IEC Directives, Part 2 (see www.iso.org/directives).

Attention is drawn to the possibility that some of the elements of this document may be the subject of patent rights. ISO shall not be held responsible for identifying any or all such patent rights. Details of any patent rights identified during the development of the document will be in the Introduction and/or on the ISO list of patent declarations received (see www.iso.org/patents).

Any trade name used in this document is information given for the convenience of users and does not constitute an endorsement.

For an explanation of the voluntary nature of standards, the meaning of ISO specific terms and expressions related to conformity assessment, as well as information about ISO's adherence to the World Trade Organization (WTO) principles in the Technical Barriers to Trade (TBT), see www.iso.org/iso/foreword.html.

This document was prepared by Technical Committee ISO/TC 221, *Geosynthetics*.

Any feedback or questions on this document should be directed to the user's national standards body. A complete listing of these bodies can be found at www.iso.org/members.html.

Introduction

The most commonly used drainage geosynthetics are the geocomposites which are produced by laminating one or two geotextiles, with a filter function, onto a drainage core. Examples are included in [Figure 1](#).

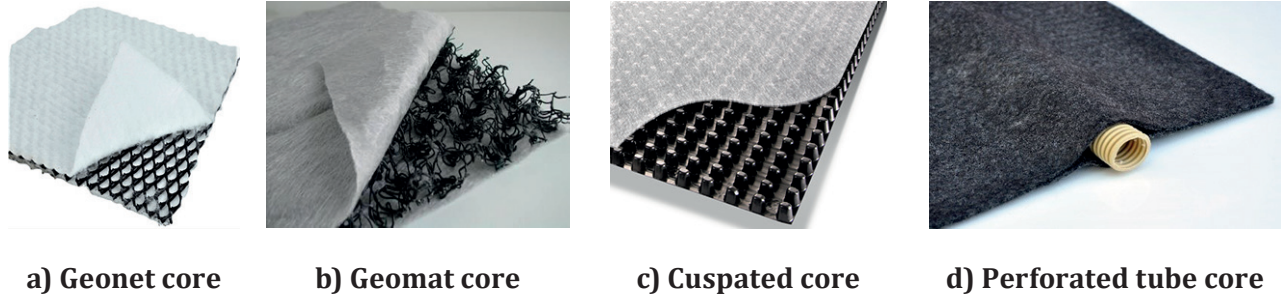

Figure 1 — Examples of drainage cores

The components generally have the following characteristics under operating conditions:

- filtering component:
 - adequate permeability to gases and liquids in the direction perpendicular to the filter plane;
 - retention capacity of the soil particles;
- drainage core:
 - adequate permeability to gases and liquids in the direction planar to the drainage structure;
 - adequate compressive strength and creep resistance for the loads to be applied.

The geocomposites are often defined by the drainage cores: geomats (GMA), geonets (GNT), geospacers (GSP), multi-linear drains.

Determination of long-term flow of geosynthetic drains

1 Scope

This document specifies methods of deriving reduction factors for geosynthetic drainage materials to account for intrusion of filter geotextiles, compression creep, and chemical and biological degradation. It is intended to provide a link between the test data and the codes for design with geosynthetic drains.

The geosynthetics covered include those whose primary purpose is planar drainage, such as geonets, cusped cores only, or cusped cores combined with laminated filter geotextiles, and drainage liners, where the drainage core is made from polypropylene and high-density polyethylene. The majority of geosynthetic drains are geocomposites with geotextiles laminated to a drainage core and it is important, where possible, to consider the drainage behaviour of the geocomposite as a whole rather than the behaviour of the component parts in isolation.

This document does not cover the strength of overlaps or joints between geosynthetic drains nor whether these might be more or less durable than the basic material. It does not apply to geomembranes, for example, in landfills. It does not cover the effects of dynamic loading nor any change in mechanical properties due to soil temperatures below 0 °C, or the effects of frozen soil. This document does not cover uncertainty in the design of the drainage structures, nor the human or economic consequences of failure. Design guidance for geosynthetic drains is found in ISO/TR 18228-4.

2 Normative references

The following documents are referred to in the text in such a way that some or all of their content constitutes requirements of this document. For dated references, only the edition cited applies. For undated references, the latest edition of the referenced document (including any amendments) applies.

ISO 10318-1, *Geosynthetics — Part 1: Terms and definitions*

3 Terms and definitions

For the purposes of this document, the terms and definitions given in ISO 10318-1 apply.

ISO and IEC maintain terminology databases for use in standardization at the following addresses:

- ISO Online browsing platform: available at <https://www.iso.org/obp>
- IEC Electropedia: available at <https://www.electropedia.org/>

4 Test equipment and procedures for determination of short-term in- plane water flow

4.1 Measurement of maximum hydraulic transmissivity and flow rate

The primary function of geosynthetic drains is to convey or transmit fluid within the flow direction(s) of a drainage layer. The discharge capacity can be given in terms of:

- Specific flow rate, which is the discharge per unit width in the geosynthetic drain, under a specified hydraulic gradient, as per [Formula \(1\)](#):

$$Q = q / B \quad (1)$$

Some users of flow tests desire to index the discharge rate per unit width to the applied hydraulic energy or hydraulic gradient at which flow is measured. In this case:

- Hydraulic transmissivity, which is the discharge per unit width of the geocomposite and per unit of hydraulic gradient, as per [Formula \(2\)](#):

$$\theta = (q / B) / i \quad (2)$$

The concepts of transmissivity and flow capacity were developed specifically to avoid consideration of the thickness as it is often difficult to specifically define the thickness of a geosynthetic drain in application.

Transmissivity is equal to flow rate only at a gradient of 1. Note also that the numerical value of transmissivity can be very different than the numerical value of the specific flow rate at small hydraulic gradients (e.g. at $i = 0,1$ transmissivity is 10 times the specific flow rate).

The discharge capacity test for a geosynthetic drain is performed in accordance with ISO 12958-1, ISO 12958-2 or ASTM D4716.

4.2 Test equipment

4.2.1 Unidirectional flow

The apparatus for these test methods are relatively simplistic in their design and ability to measure a discharge capacity or flow rate per unit width or transmissivity ([Figure 2](#)). By maintaining a constant head during the test, at a given normal stress, boundary conditions, and seating time, the flow rate Q of the geosynthetic drain can be determined using [Formula \(3\)](#):

$$Q_{\sigma,i,t,b} = \frac{q}{B} \cdot R_T \quad (3)$$

Where

- $Q_{\sigma,i,t,b}$ is the numerical value of the in-plane water flow capacity per unit width at a defined stress σ , gradient i , seating time under load prior to flow measurement t and boundary conditions b , [l/(m·s)]
- q is the numerical value of the discharge capacity for a geosynthetic drain of width B measured in the test (l/s);
- B is the numerical value of width of flow (m)
- R_T is the numerical value of the correction factor converting to a test temperature of 20 °C.

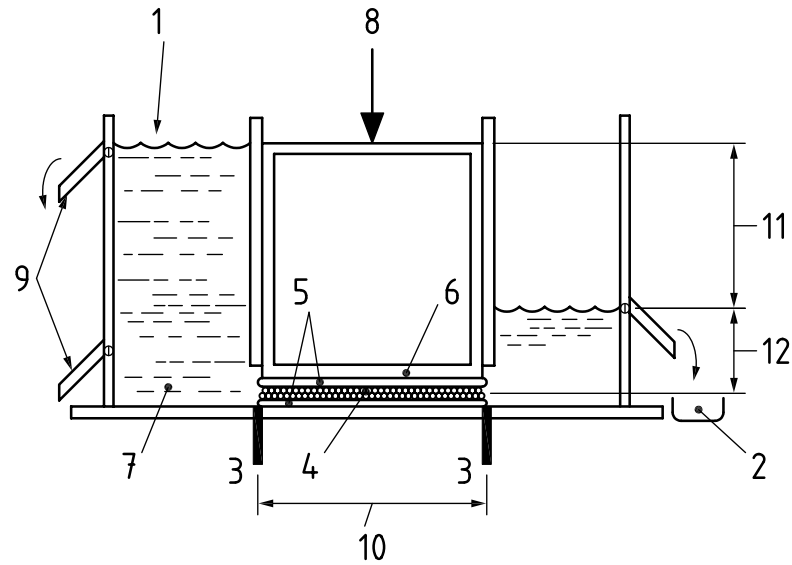
**Key**

- | | | | |
|---|--|----|--|
| 1 | water supply | 7 | water reservoir |
| 2 | water collection | 8 | normal compressive load |
| 3 | upstream water head manometers / piezometers | 9 | overflow weirs |
| 4 | specimen | 10 | effective flow length (≥ 300 mm) |
| 5 | material used as boundary (e.g. soil) | 11 | water head of discharge |
| 6 | loading platen | 12 | downstream water head (≤ 100 mm) |

Figure 2 — Example of test apparatus in horizontal test configuration

ISO/PRF TS 18198

<https://standards.iteh.ai/catalog/standards/sist/486d1329-b363-4226-9c4a-ea244ab57e09/iso-prf-ts-18198>

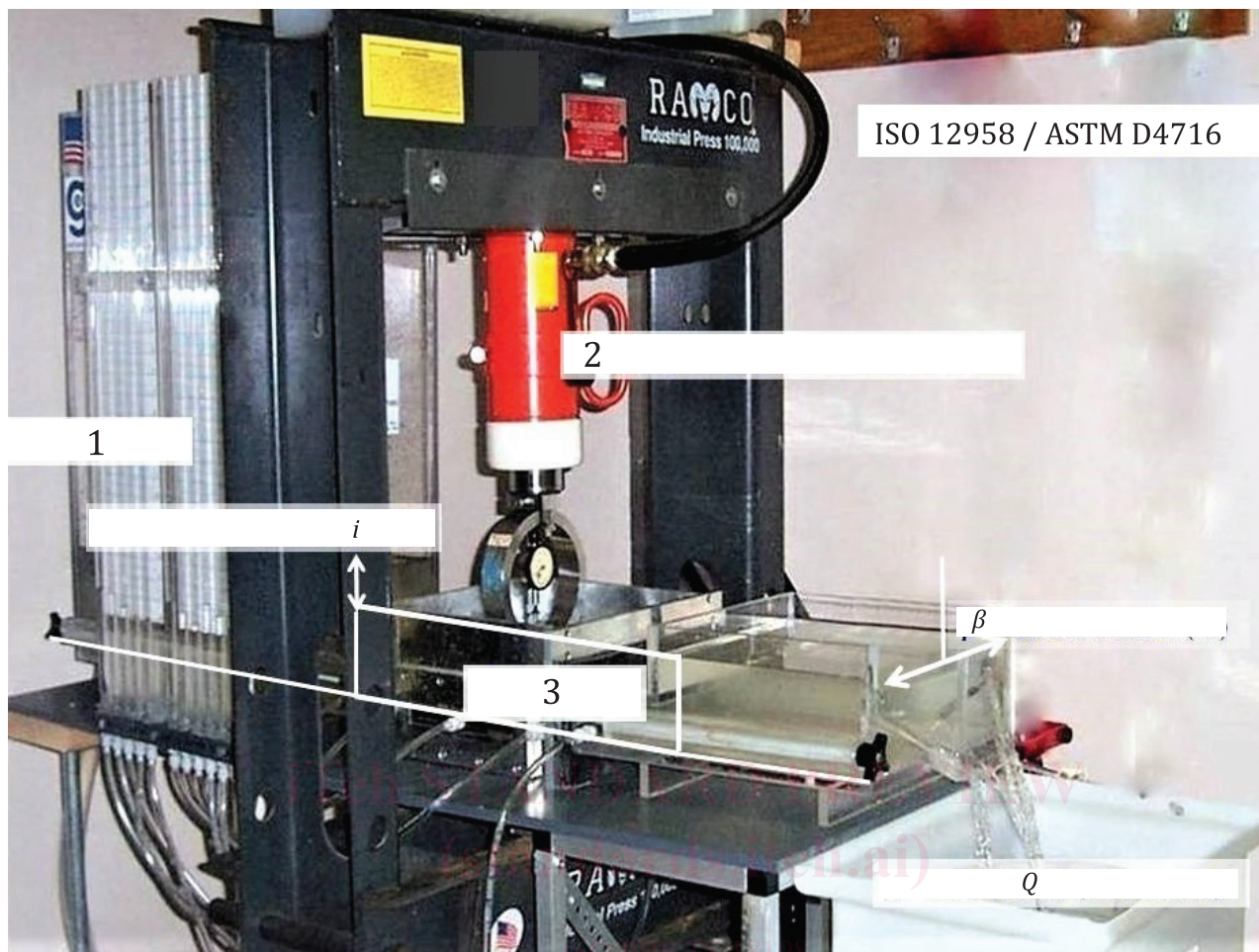
**Key**

- 1 manometers
 2 normal compressive loading ram
 3 test box
 i H/L = Hydraulic gradient
 β width of flow (m)
 Q rate of flow ($\text{m}^3/\text{sec}\cdot\text{m}$)

<https://standards.iteh.ai/catalog/standards/sist/486d1329-b363-4226-9c4a-ea244ab57e09/iso-prf-ts-18198>

Figure 3 — Example of test equipment for water flow capacity of planar drainage geosynthetic

The test equipment shown in [Figure 3](#) has the ability of constructing specific design cross-sections within the apparatus and then applying the required load(s) to the product, for which the geosynthetic drain shall perform in the proposed design. The normal load is applied vertically across the entire sample cross-section, typically by a pneumatic bladder or loading piston. The hydraulic gradient for the test is set by adjusting the hydraulic head H prior to the start of the test.

While sharing a number of common technical features for measuring flow, a specific flow capacity test as performed may differ slightly in testing details and prescribed procedural approaches. Depending on which manner a test is performed, the resulting data may be either of “index” type suitable for use in manufacturing quality control (see ISO 12958-1 or ASTM D4716), or of a “performance” type suitable for use in design and performance verification (see ISO 12958-2 or ASTM D4716). ISO 12958-1 prescribes flow measurements at predetermined hydraulic gradients and normal compressive stresses, as well as standardized superstratum and substratum (closed cell foam materials or rigid boundaries). The procedures in ISO 12958-2 and ASTM D4716, instead, invite the user of the test to determine all of the test parameters specific to the designed drainage application. For performance testing, as an example, the following test parameters or variables should be specified so as to represent anticipated

or site-specific conditions such as: compressive load, hydraulic gradient, temperature, site-specific superstratum, site-specific substratum, and seating time prior to flow measurement.

4.2.2 Index and performance tests

Manufacturers typically quantify the relative capacity of their geosynthetic drainage products via index testing and document this performance on marketing documents and material data sheets. However, manufacturer's testing often reflects the flow rates of the product tested between two rigid plates, or standardized closed cell foam pads, under a specific load and gradient, and with a limited seating time (i.e. 15 min, 1 h, etc.). Thus, the manufacturer's data typically represents the short-term flow capacity for the product and serves to confirm production quality control.

To approach an understanding of the performance-related flow capacity of the geosynthetic drain it shall be tested using test parameters representative of field service conditions. Testing to provide an estimate of performance flow is described in ISO 12958-2 and ASTM D4716.

A performance flow test should allow materials above and below the geosynthetic drain to intrude into the void space of the product under compressive load to simulate real project conditions. Sand, for example, placed above the drain and loaded to design conditions will cause the upper filter geotextile to elongate and intrude into the space between each parallel strand of a geonet or the cusps of the cusped core. The degree of intrusion has a direct relationship to the structural properties and bonding/no bonding and type of bonding (to the core) of the geotextile specified for the drain core and the amount of normal load applied to the design cross-section. Please note that the design engineer will need to supply the testing laboratory with a sufficient volume of representative soil sample to perform the number of required tests. The compaction requirements for the soil shall also be specified in order to set-up the test section to reflect the design conditions. If a geosynthetic clay liner is adjacent to the geosynthetic drain, the degree of saturation shall be specified along with the load at hydration, prior to placement of the normal load on the design cross-section test sample.

The ISO 12958-1 test procedure defines closed-cell foam materials meeting specific compressibility characteristics to simulate these field conditions. These "soft" superstratum and substratum materials assist in replicating test conditions and also avoiding contamination of test water with site-specific soils. Use of these standardized superstratum and substratum also enable manufacturers to publish like-data on their drainage products for product comparison while providing their own estimate of performance flow. ISO 12958-2 and ASTM D4716 allow use of site representative soils and other materials to more closely replicate field conditions.

4.3 Normal compressive loading and seating time

For performance testing, the normal stress used during testing should be equal to the maximum overburden pressure the material may experience during its service life. The practice of specifying a test pressure higher than anticipated field pressure is conservative when following the most common design procedures. Any uncertainties associated with long-term flow performance under load may be accounted through a factor of safety rather than a higher than expected normal pressure.

Most geosynthetic drains are constructed of polymeric material, which can deform under load and over time. This gradual deformation of the polymeric structure under a fixed load is known as "creep." The rate of ductile movement occurs rapidly initially (primary creep) and decreases overtime (secondary creep).